

BRAUN



CONSUMER

Foldout Ramp

ENTERVAN®

**Wheelchair-Accessible
Lowered Floor Conversion
featuring 2005 and Newer
GM Minivans**

**THE BRAUN
CORPORATION®**

"Providing Access to the World"®

International Corporate Hdqrs: P.O. Box 310 Winamac, IN 46996 USA
1-800-THE LIFT® (574) 946-6153 FAX: (574) 946-4670
braunmobility.com™ entervan.com™



**31913 Rev A
January 2006**

**Patent # 6,825,628 B2
Patent Pending**

Operator's Manual

! WARNING



**Read manual
before operating.
Failure to do
so may result in
serious bodily
injury and/or
property damage.
Keep manual in
Entervan.**

**Foldout Ramp Entervan®
featuring GM Minivans**

Congratulations

We at The Braun Corporation wish to express our fullest appreciation on your new purchase. With you in mind, our skilled craftsmen have designed and assembled the finest lowered floor vehicle available.

This manual includes safety precautions, operating instructions, manual operating instructions, and instructions for maintenance and lubrication procedures.

Your Entervan® is built for dependability, and will bring you years of pleasure and independence, as long as the maintenance is performed regularly and the Entervan® is operated by an instructed person.

Sincerely,

THE BRAUN CORPORATION

A handwritten signature in black ink that reads "Ralph W. Braun". The signature is written in a cursive style with a large, sweeping "B" and "R".

Ralph W. Braun
Chief Executive Officer

WARRANTY AND REGISTRATION INSTRUCTIONS	2	Ramp Safety	18-20
INTRODUCTION	3	WHEELCHAIR AND OCCUPANT RESTRAINT	21-29
ENTERVAN OPERATION QUICK REFERENCE GUIDE	4, 5	SEAT REMOVAL AND INSTALLATION	
FEATURES	6, 7	Front Seats (General Information)	30
SAFETY PRECAUTIONS	8	Front Seat Electrical Harnesses	31-33
OPERATION		Quick-Release Front Seat Base	34
Terminology	9	Front Seat Removal/Installation Instructions	35
One-Touch Control System	9	Third Row Seats	36
Control Switches	10-12	WARRANTY	37-40
Ramp Access Sliding Door	13	RETURN AUTHORIZATION PROCEDURE	40
Kneel System	14	PREVENTIVE MAINTENANCE	41, 42
Power Ramp	15-17	JACKING AND TIRE CHANGING	42
Power Ramp Operation	15	AUXILIARY POWER SUPPLY / BELOW FLOOR OBSTRUCTIONS / WELDING	43-48
Power Ramp Safety	16	FUSES	49
Power Ramp Manual Operation	17	REPORTING SAFETY DEFECTS	50
Non-Power Ramp	17		

WARRANTY AND REGISTRATION INSTRUCTIONS

Examine your Entervan® for any damage. Should any damage have occurred during delivery, notify the carrier at once with any claims.

The warranty/registration card shown here is supplied with each Entervan®. Review the delivery checklist and fill out the warranty registration information with your sales representative and mail it to The Braun Corporation.

A detailed Warranty section is provided within this manual. The **warranty card must be processed to activate the warranty.**

Record the last eight digits of the vehicle identification number (VIN) in the space provided for future reference. **This information must be provided when filing a warranty claim or ordering parts.**



Note: Attached to glove box door.

A photograph of the actual forms. The top form is the 'DELIVERY CHECKLIST'. It has a header with the title 'DELIVERY CHECKLIST' and a small image of a silver van. Below the title are fields for 'Customer Name:', 'VIN:', 'Delivery Date:', and 'Dealer/Sales Consultant:'. The main body of the form is divided into sections: 'Pre-Delivery (to be completed by Sales Consultant prior to Customer being present)', 'Delivery (to be reviewed by Sales Consultant with Customer present)', 'Estimate', 'Insure', and 'Additional'. Each section contains a list of items to be checked, with checkboxes. The bottom form is the 'WARRANTY REGISTRATION'. It has a header with the title 'WARRANTY REGISTRATION' and a small image of a man sitting on a small vehicle. Below the title are fields for 'Dealer Purchased From:', 'City:', 'State:', and 'Date of Purchase:'. There is also a section for 'Owner Information' with fields for 'Name:', 'Address:', 'City:', 'State:', 'Zip:', 'Telephone:', and 'Email:'. At the bottom of the form, there is a note: 'This registration card must be returned to The Braun Corporation to activate the Entervan's Three-Year Worry-Free Warranty.'

Vehicle Identification (VIN) Number _____

The Braun Entervan® lowered floor conversion is designed to provide years of pleasure and mobility independence. Familiarity with proper operation and maintenance procedures will help ensure safe, trouble free operation.

The Braun Corporation encourages wheelchair passengers and their attendant(s) to review the material contained in this manual with your Entervan® sales representative, **before attempting operation**. Any questions or concerns can be answered by your sales representative at that time.

This manual addresses Entervan® standard features as well as options. Refer to the instructions applicable for your package, and disregard the information that does not apply.

The Entervan® Operation Quick Reference Guide hanging on the mirror provides a condensed explanation of Entervan operation (shown at right). Read the guide and then insert it in this manual for future reference. **Note:** An Operation Quick Reference Guide (overview) section is provided on pages 4 and 5 of this manual also.

Contact The Braun Corporation at 1-800-THE LIFT® if any of this information is not understood.

Store this manual in the vehicle along with your GM owner's manual.

If you experience an operation problem or there is any sign of wear, damage, or other abnormal condition, contact your sales representative or call The Braun

Corporation at 1-800-THE LIFT®. One of our national Product Support representatives will direct you to a Braun authorized service center.

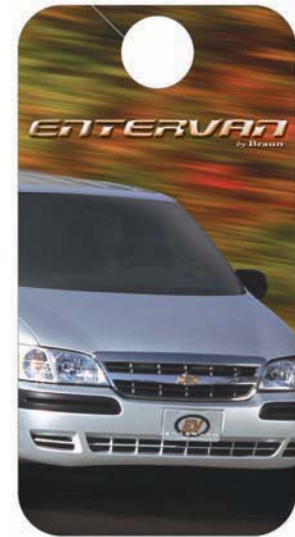

Operation Quick Reference Guide

ENTERVAN OPERATION QUICK REFERENCE GUIDE

Entervan Operation Overview

This overview provides a simplified explanation of Entervan operation. Read the entire owner's (operator's) manual for complete details. Contact The Braun Corporation at 1-800-THE LIFT® if any of this information is not understood.

Power Operation

Entervan power functions are managed by the One-Touch electronic control system. The control system can be activated using the GM remote keyless entry transmitter, any one of the interior-mounted control switches or the optional magnetic entry. Details on pages 10-12.

GM
Remote
Keyless
Entry
Transmitter



Press
and
release
this
switch
(button).

Control switches display the slide door graphic.



One-Touch Control Activation

Entervan power door and power ramp functions are activated by **pressing and releasing** any control switch.

Open Functions: When activating the Open functions, the power door opens, the kneel system lowers the rear of the vehicle and the power ramp unfolds.

Close Functions: When activating the Close functions, the power ramp folds, the kneel system raises the rear of the vehicle and the power door closes.

Manual Operation

In event of power or equipment failure, the door, ramp and kneel system can be manually operated. Read this manual for further details.

Operating Your New Entervan Couldn't Be Simpler . . .



1 Just press any one of the buttons like the one pictured above. . .

2 And the sliding door opens



3 The rear suspension lowers

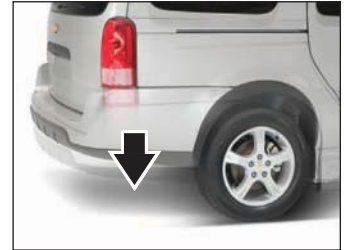

4 The ramp depolys

5 Allowing easy entrance!



FEATURES

One-Touch Electronic Control System: The Entervan One-Touch electronic control system provides simple one-touch activation of all Entervan power features. For your convenience, the control system can be activated using the GM remote keyless entry transmitter, any one of the interior-mounted control switches or the optional magnetic entry.

Power Slide Door: The One-Touch electronic control system activates the passenger side power slide door for ramp access. The slide door and lowered floor configuration provides 56" clear vertical passageway.

Note: The driver-side sliding door is lowered to provide clear passage also.

Ramp: Fully automatic power ramps and manually operated ramps are available in 30" width.

Electromechanical Power Kneeling Rear Suspension: "Kneeling" is the lowering motion of the electromechanical rear suspension. The kneel feature reduces the slope of the ramp when deployed.

Lowered Floor from Rear Axle to Firewall: This feature provides additional headroom (59-1/2" floor-to-ceiling at center of van). The lowered floor reduces the slope of the ramp when deployed. Carpeting is featured throughout the lowered floor area.

Ground Effects: Exterior color matched ground effect panels

conceal the lowered floor and lowered sliding doors.

Floor Track for Wheelchair and Occupant Securement in Midpoint Lowered Floor Area: Floor track provided in the midpoint lowered floor area (Position **C**) can be utilized for restraint of wheelchair passenger(s). Wheelchair capacity at midpoint may have limitations based on the dimensions of specific wheelchairs.

Forward-Facing Wheelchair and Occupant Belt/Track System: One Forward-Facing Wheelchair and Occupant Belt Kit is supplied for the restraint of one wheelchair and occupant. The belt kit is used in conjunction with the floor track. **Note:** Additional belt kits can be purchased (option).

Quick-Release Front Passenger Seat with Floor Track for Wheelchair and Occupant Securement:

The passenger seat (Position **B**) is equipped with GM's quick-release seat attachments (making seat removal and installation procedures simple). The seat can be removed and the seat location can be utilized by a wheelchair occupant (floor track provided).

Driver Seat: For the wheelchair occupant who chooses to drive the Entervan, this seat (Position **A**) can be removed and adaptive driving systems custom tailored for the individual can be purchased from and installed by your local mobility dealer. The driver side seat is equipped with GM's quick-release seat attachments also. 58" floor-to-ceiling head-

room is provided at both front seating positions.

Auxiliary Power Supply for Dealer-Installed Power Seat or Electric Tie-Downs: This power source is available to accommodate adaptive driving systems custom tailored for the individual (purchased from and installed by your local mobility sales representative). See pages 43-48.

Interior Spare Tire Mount: The spare tire is mounted behind the third row seats. The jack is located in the GM specified storage compartment at rear of the vehicle (passenger's side).

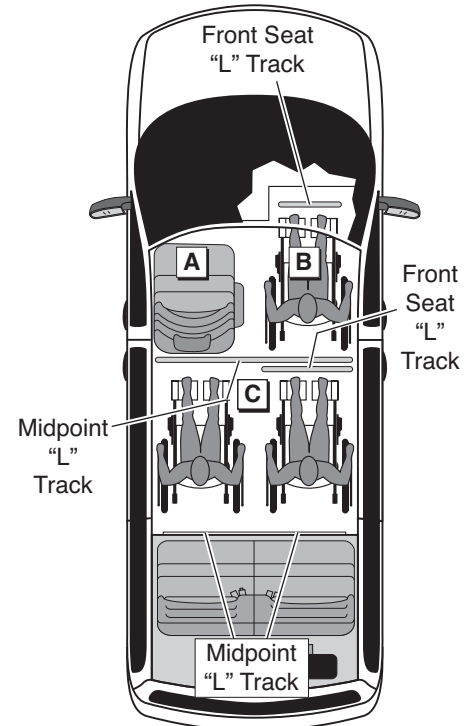

Available Wheelchair Positions

SAFETY PRECAUTIONS

Safety Symbols

SAFETY FIRST! Know That....

A All information contained in this manual and supplements (if included), is provided for your safety. Familiarity with proper operation instructions as well as proper maintenance procedures are necessary to ensure safe, trouble free operation. Safety precautions are provided to identify potentially hazardous situations and provide instruction on how to avoid them.

B



C

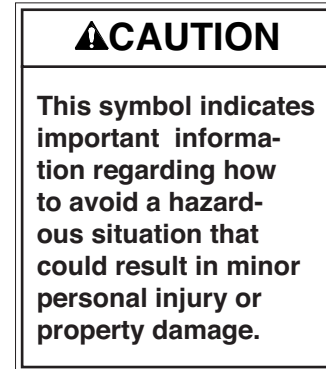

D **Note:** Additional information provided to help clarify or detail a specific subject.

These symbols will appear throughout this manual and may appear on labels posted on your Entervan.
Recognize the seriousness of this information.

Whenever parking your Entervan and before utilizing Entervan features, always engage the vehicle transmission in Park “P” and engage the vehicle parking brake. The vehicle transmission **must** be engaged in Park “P,” before operating the Entervan automatic features. Entervan power functions cannot be activated if the vehicle transmission is not in Park. **Note:** Pressing the overhead console power override switch disables Entervan functions also (if equipped).

Terminology

The term “Unfold” indicates the lowering motion of the ramp to the deployed position. “Fold” is the raising motion of the ramp to the vertical (stowed) position.

The terms “Open” and “Close” refer to sequences of power functions that will occur when activated by the One-Touch electronic control system. When activating the Open functions, the power door opens, the kneel system lowers the rear of the vehicle and the ramp unfolds. When activating Close functions, the ramp folds, the kneel system raises the rear of the vehicle and the power door closes.

One-Touch Control System

Entervan power functions are managed by the One-Touch electronic control system. The control system can be activated using the GM remote keyless entry transmitter or any one of the controls addressed on pages 10-12.

Do not attempt to interface aftermarket control systems.

Braun Corporation Aftermarket Control Systems Policy:

The Braun Corporation manufactures dedicated control systems for its products. These control systems have been designed and tested for use in conjunction with specific Braun products. Braun control systems are the **only** control systems authorized for use with Braun products.

Do not attempt to interface aftermarket control systems without authorization from The Braun Corporation. **To do so may result in serious bodily injury and/or property damage.**

OPERATION

Control Switches

For your convenience, the Entervan One-Touch electronic control system can be activated using the GM remote keyless entry transmitter, any one of the specified interior-mounted control switches or the optional magnetic entry (control photos and details are provided).

One-Touch Control Activation

Entervan power door, ramp and kneel functions are activated by **pressing and releasing** any specified control switch.

Note: The overhead console power override switch must be off to activate power door and ramp functions (see page 11).

GM Remote Keyless Entry Transmitter

Using the GM remote keyless entry transmitter eliminates the need of an additional remote control.



Press and release this switch (button).

Remote Switch:
Press switch displaying this slide door graphic.



Dash-mount Console Switches

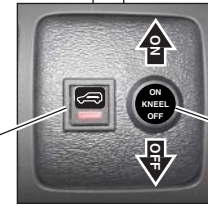

Open/Close Switch: Press and release switch to activate Entervan power functions.

Kneel On/Off Switch: Press to ON position to activate kneel feature. Press to OFF position to disable kneel feature.

Overhead Console Switches

The switches in the overhead console switch bank vary based on vehicle options. If equipped with a passenger side power door only, the switches will be as shown here (one control switch and one override switch). If the override

switch is pressed, power door, ramp and kneel functions will be disabled.



If equipped with dual power sliding doors, there will be two combination switches (one for each door). Door power and power override are controlled with the same switch (both graphics appear on switches).

Power Override:



Pressing this switch disables powered door and ramp functions.

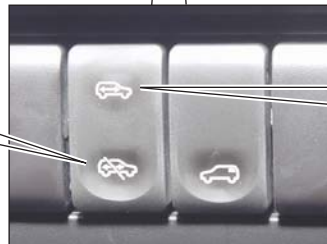

Door Power:



Press and release this switch for Enter-van power functions.

“B” Pillar Switch

A switch is located on the wall panel ahead of the passenger side slide door (“B” pillar).



Press and release this switch.



OPERATION

“C” Pillar Switch

A switch is located on the wall panel rear of the passenger side slide door (“C” pillar).



Press and release this switch.

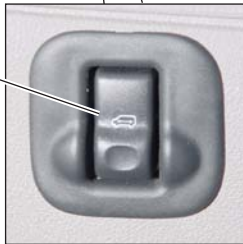

Magnetic Entry

The magnetic entry is offered as an **option**. A magnetic switch is built into the passenger-side rear panel (near taillight). The switch is labeled OPEN/CLOSE.

A keychain-style magnet is supplied for switch activation, see photo below. Simply align the magnet tip with the switch target (identified with decal 28013) and Entervan power door, ramp and kneel functions will be activated.

Delay Feature: When activating the Open functions using the magnetic entry, there is a **one second delay before** the Entervan Open sequence of functions is activated. The One-Touch electronic control system unlocks all vehicle doors before activating Entervan power functions.

Align Tip with Magnetic Switch

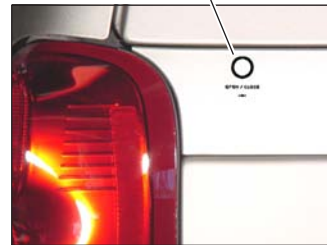

Passenger Side Taillight Assembly



Keychain Magnet

Magnet Tip

Ramp Access Sliding Door

The passenger side power sliding door may be opened using the Entervan One-Touch Control System or it may be opened manually. Press and release the GM remote keyless entry transmitter, any one of the interior-mounted control switches or use the optional magnetic entry to activate the door. When a control switch is pressed, the door will open and the Open sequence of functions will continue.

If a control switch is pressed and released while the door is opening, the door will open fully and stop (ramp will not deploy). Press the switch again and the door will close.

Once the Open sequence of functions is complete (door is fully open and ramp is unfolded), press and release a control switch to close the door. The door will close after the ramp folds, completing the Close sequence of functions.

If a control switch is pressed while the door is closing, the door will continue to close fully. Press a control switch again to start Open functions.

Note: The overhead console power override switch must be off to activate the power door. The door can be opened and closed manually if the override switch is pressed on. If the override switch is off and you attempt to open or close the door manually, the power feature will automatically complete the function.

Note: If the power door is obstructed while opening or closing, the door will reverse direction, provided it meets sufficient resistance.

Keep clear of the area in which the power door operates. Ensure door travel path is clear. Personal injury or property damage may occur during power door operation. Be sure the door is fully closed and latched before driving.

WARNING

Keep clear of area in which power door operates. Failure to do so may result in bodily injury and/or property damage.

OPERATION

Kneel System

Kneeling is the lowering motion of the Entervan electromechanical rear suspension. The kneel system lowers the rear of the vehicle. Lowering the rear of the vehicle reduces the slope of the ramp.

The kneel system is automatically activated by the One-Touch electronic control system. When a control switch is pressed to start the Open functions, the rear of the vehicle begins to lower at the same time the door starts to open. When the Close functions are activated, the vehicle starts to raise at the same time the ramp starts to stow (retract).

Note: Do not leave your Entervan in the kneeled (lowered) position for extended periods of time. Doing so may result in battery drain.

Kneel On/Off Feature: A Kneel On/Off feature is incorporated into the One-Touch electronic control system. This feature provides the **option** of kneeling the vehicle when operating the power door and power ramp. The Kneel On/Off switch must be in the ON position in order for the kneeling system to be activated (photo on page 10).

Mechanical Kneeling Override: In the event the Entervan is in the kneeled position and you experience power or equipment failure, the Kneel Actuator Manual Release (Override) feature allows the rear of the vehicle to be raised to the normal position.

Use the Kneel Manual Release **only** if the vehicle will not raise electrically. **Do not** drive the Entervan with the rear of the vehicle in the lowered position. Attempting to do

so will result in an extremely rough and unstable ride. In the event of a kneel system failure, have the kneel system repaired immediately. A release handle is located under the rear bench seat as shown below.

To Release Kneel: Pull release handle forward and down.

To Engage Kneel: Lift and push release handle rearward.

Kneel System Manual Release Handle

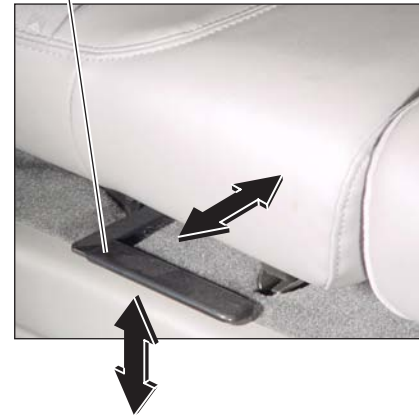

Power Ramp

Fully automatic power ramps and manually operated ramps are available.

Power Ramp Operation: The power ramp is activated by the One-Touch electronic control system. When a control switch is pressed to start the Open functions, the ramp unfolds after the door is fully open. When the Close functions are activated, the ramp folds immediately.

If a control switch is pressed and released while the ramp is unfolding, the ramp motor will stop running. Press a switch again and the ramp will fold and the door will close.

Once the Open sequence of functions is complete (door is fully open and ramp is unfolded), press and release a control switch to fold the ramp. If a control switch is pressed while the ramp is folding, the ramp motor will stop running. Press a control switch again and the ramp will fold and the door will close.

Note: If the power ramp is obstructed while unfolding or folding, the ramp motor will stop running, provided it meets sufficient resistance. If the ramp is obstructed during the unfold cycle, press the switch again and the ramp will fold and the door will close. If obstructed during the fold cycle, the ramp motor stops running and the ramp unfolds by the force of gravity.

Note: When unfolding the ramp, the ramp motor stops running when the ramp reaches the nearly-horizontal position (approximately 6" - 8" above ground level). The ramp continues to slowly lower the remaining distance by the force of gravity.

Allow the power ramp to unfold (deploy) fully before boarding the ramp. Forcing the ramp out or down during the unfold function, or boarding onto the ramp before it is fully-deployed **may result in damage** to the ramp, the electronic controller and/or motor assembly.

▲ CAUTION

Allow ramp to deploy fully before boarding. Failure to do so may result in damage.

OPERATION

Power Ramp Safety: Be certain there is adequate clearance outside the Entervan before unfolding the power ramp.

Keep clear of area in which the ramp operates. Be certain no person or obstruction is within the path of the ramp when unfolding or folding the ramp. Keep clear of all power ramp moving parts. Do not attempt to grip or hold the ramp or ramp folding mechanism (fold arm and bearing assembly).



Keep body parts and obstructions clear of the area in which the ramp operates.

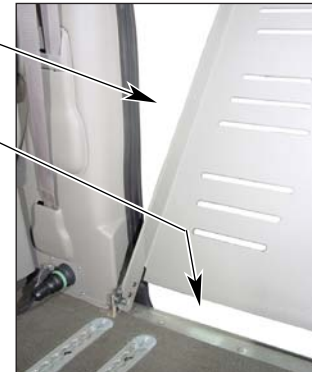

Power Ramp Manual Operation: If you experience power or equipment failure, power ramps can be manually folded and unfolded. The power ramp can be unfolded and folded manually if the overhead console power override switch is pressed on also.

Use the **HAND HOLD** to **carefully** unfold and fold the ramp.

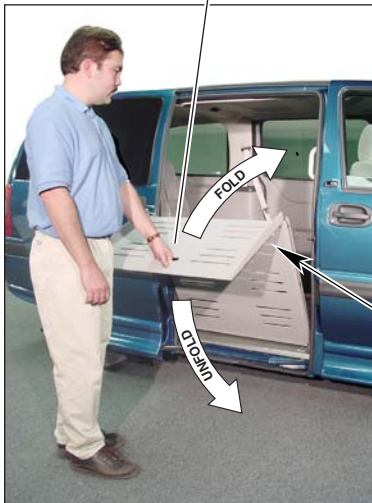

Keep clear of hinge area.

Have an assistant manually unfold and fold the ramp. Push ramp out **only** if assistant is not available. See following section also.

Non-Power Ramp: Non-power ramps must be manually unfolded and folded by an attendant. An oval-shaped **HAND HOLD** slot is provided on the ramp (see photo at left). **Carefully** unfold and fold the ramp using the **HAND HOLD**.

Keep clear of the area in which the hinged ramp bi-fold extension folds and unfolds. Remember to use good body mechanics when folding and unfolding the ramp.

The safety precautions addressed in the Power Ramp section apply to use of a manual ramp also. **Read and become familiar with all ramp safety precautions.** Follow these additional precautions exclusive for manual ramps also. Do not release the ramp when manually unfolding or folding the ramp. The ramp will free-fall. Do not push the ramp out from inside the vehicle. The ramp will free-fall. Push ramp out **only** if an assistant is not available.

Ramp Safety

Wheelchair passengers and attendants (when applicable), must use basic common sense and good judgment regarding ramp safety. Each wheelchair passenger has a unique set of physical abilities combined with the physical characteristics of his or her wheelchair that dictate the method in which he or she will enter and exit the Entervan. Consequently, the procedures for safe operation outlined in this manual are general in nature. Wheelchair attendants should be instructed on any special needs and/or procedures required for safe transport of wheelchair passengers.

Follow all safety instructions regarding torso restraints, stability, balance, weight distribution and use of attendants as specified in the owner's manual supplied with **your** wheelchair. Determine, establish and practice ramp boarding and exiting procedures under the direction of your health care professional, your wheelchair representative, and your Entervan sales representative to **ensure your ability to do so safely**.

Never board an Entervan ramp if you or your attendant are intoxicated. The wheelchair should be positioned in the center of the ramp at all times. You must be able to clearly view the ramp whenever boarding and exiting the vehicle.

It is the responsibility of the wheelchair operator to enter and exit the Entervan on the ramp in the safest manner.

Wheelchair-Equipped Occupant Seat Belts:

Wheelchair passengers should position and buckle their wheelchair-equipped seat belt (torso restraint), as specified by the manufacturer, **before** loading onto a wheelchair ramp.

⚠ WARNING

Position and fasten the wheelchair-equipped occupant seat belt before loading onto the wheelchair ramp. Failure to do so may result in serious bodily injury and/or property damage.

Different types of disabilities require different types of wheelchairs and different types of wheelchair-equipped occupant restraint belt systems (torso restraint). It is the responsibility of the wheelchair passenger to have his or her wheelchair equipped with an occupant restraint (seat belt) under the direction of their health care professional.

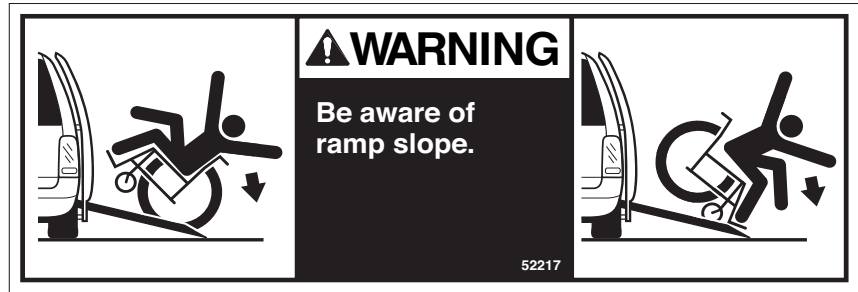

Stabilizing Wheelchairs: Powered and manual wheelchairs are designed to remain upright and stable during normal operation. All activities which involve movement in a wheelchair have an effect on the combined center of gravity of the occupant and wheelchair. Be aware of the Entervan ramp slope (angle). The slope of the ramp has a direct effect on the center of gravity. Keep in mind your center of gravity and your ability to maintain stability and balance.

Do not operate your wheelchair on the Entervan ramp without assistance if you are unable to maintain stability and balance. Counterbalance devices (anti-tippers) may be available from your wheelchair representative to enhance stability and balance.

Do not tilt your wheelchair without assistance. Operate the wheelchair at a slow and constant speed when on the ramp. Do not accelerate suddenly when on the ramp. Do not raise the front wheelchair wheels (pull wheelie) when on the Entervan ramp.

OPERATION

The aid of an attendant stabilizing the wheelchair is recommended for **optimum safety**. Wheelchair passengers who intend to enter and exit their Entervan without the assistance of an attendant must determine the safest and most practical method and orientation of entering and exiting the Entervan based on the physical characteristics of their personal wheelchair and his or her physical capabilities to maintain stability while the wheelchair is in motion on the Entervan ramp.

Wheelchair Attendants: When assisting a wheelchair occupant, remember to use good body mechanics. When the wheelchair is on the ramp, the attendant must grasp the push handles (or other) securely. Detachable wheelchair parts such as arms or leg rests must never be used for hand holds or lifting supports. Doing so could result in the detachable parts being inadvertently detached from the wheelchair **resulting in possible injury to the wheelchair occupant and/or the attendant.**

Wheelchair Orientation and Securement During Transport: The wheelchair and occupant **must** face the front of the vehicle and **must** be secured using the Forward-Facing Wheelchair and Occupant Belt and Track System when riding in the Entervan. See pages 21-29 for details.

WHEELCHAIR AND OCCUPANT RESTRAINT

One Forward-Facing Wheelchair and Occupant Belt Kit is supplied for the restraint of one wheelchair and occupant (details follow). “L” track is mounted in four locations in the vehicle for belt securement (shown in Figure 1).

Note: Wheelchair passengers shown in Figure 1 depict the available seating positions. Wheelchair capacity at Midpoint (Position **C**) may have limitations based on the physical dimensions of specific wheelchairs. Additional Forward-Facing Wheelchair and Occupant Belt Kits must be purchased for the restraint of each additional wheelchair passenger.

The Entervan offers the following options for placement and securement of wheelchair passengers.

Driver Seat: This seat (Position **A**) can be removed and adaptive driving systems custom tailored for the driving wheelchair occupant can be purchased from and installed by your local sales representative.

Front Passenger Seat with Floor Track: The passenger seat (Position **B**) can be removed and the seat location can be utilized by a wheelchair occupant.

Midpoint Lowered Floor Area with Floor Track: The Midpoint lowered floor area (Position **C**) can be utilized by wheelchair occupants (capacity limitations apply).

Refer to the following guidelines, illustrations, photos and instructions for proper use of the belt and track restraint system.

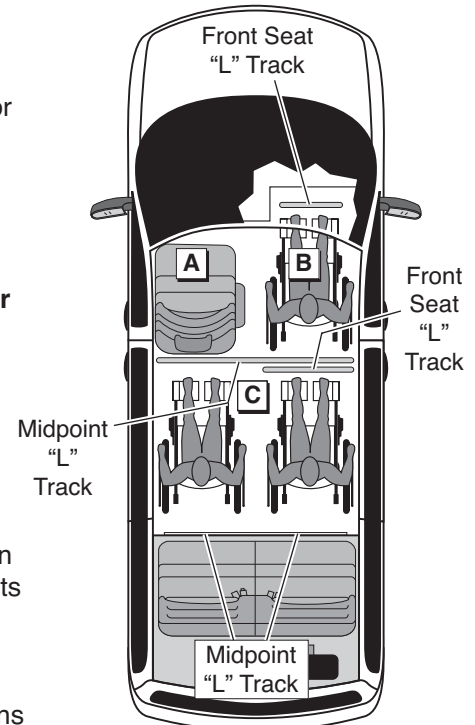

Figure 1

WHEELCHAIR AND OCCUPANT RESTRAINT

⚠️ WARNING

No product developed to date can guarantee successful securement of the wheelchair, even at low speeds, in the event of an accident. The Braun Wheelchair and Occupant Belt/Track System does meet the most widely referenced Federal Motor Vehicle Safety Standards used for contemporary restraint equipment. However, this equipment does not ensure stability of the wheelchair in the event of an accident at any speed.

Wheelchair Securement: Four adjustable over-center buckle belts are provided for securement of the wheelchair (two for the front and two for the rear).

The belts are equipped with one keeper fitting (attachment) which installs in the vehicle-mounted “L” track (details on pages 24 and 25). A hook is positioned on the opposite end of the belts for attachment to a solid frame member of the wheelchair. Do not attach belts to detachable wheelchair components such as armrests or leg rests. Front and rear belt tension is required.

Refer to the illustrations, photos and instructions on pages 24-29 for belt operation procedures.

Over-Center Belts
(four supplied)



Lap Belt Extension
(Midpoint)



Lap Belt Extension
(Front Seats)



Note: Two lap belt extensions are supplied (as shown). Midpoint and front seat lap belt extensions are **not interchangeable**.

Wheelchair Passenger Securement: Two lap belt extensions are supplied for securement of the wheelchair occupant. The lap belt extensions are equipped with a keeper fitting (attachment) which installs in the vehicle-mounted “L” track. A female receptacle is positioned on the opposite end of the extension for attachment to a GM factory-installed upper torso lap and shoulder belt.

Note: The midpoint lap belt extension is a standard belt style assembly (adjustable). The front seat extension is equipped with a rigid cable (nonadjustable). See photos on page 22. Lap belt extensions are **not interchangeable**. Attachment procedures are identical. See the illustrations on pages 26 and 27 and photos on page 29.

Operate the GM lap and shoulder belt as instructed in your GM owner’s manual. Follow all safety precautions. Connect the GM lap and shoulder belt to the lap belt extension. Position the upper torso (shoulder) belt across the center of the shoulder. Position the lap belt low across the front of the pelvis (near hip). See the illustrations on pages 26 and 27 and photos on page 29.

Position of the lap belt buckle, after adjustment, is to be located near hip position. The belt is to be worn low and snugly. Adjustment of the lap belt extension is to be made at adjuster buckle. Wheelchair occupant restraints should not be held away from the body by wheelchair components such as armrests or wheels.

Keep belts clear of sharp objects. Do not alter belts. Do not interchange belts from one position to another. Keep the supplied belts together as a complete set.

Belt and Track Maintenance: Inspect belt assemblies frequently. Any defects such as belt cuts, fraying or malfunctioning call for replacement of the entire belt assembly. “L” track must be clean and not worn, bent or otherwise damaged (prohibiting proper belt attachment). If there is any sign of damage, wear, abnormal condition or improper operation of belts, belt hardware (hooks, keepers, latch plate, receptacle), or track, discontinue use and replace components immediately.

Severe conditions (weather, environment, heavy usage, etc.) may require more frequent inspections. Exposure to severe conditions will dramatically reduce the life of the system.

WHEELCHAIR AND OCCUPANT RESTRAINT

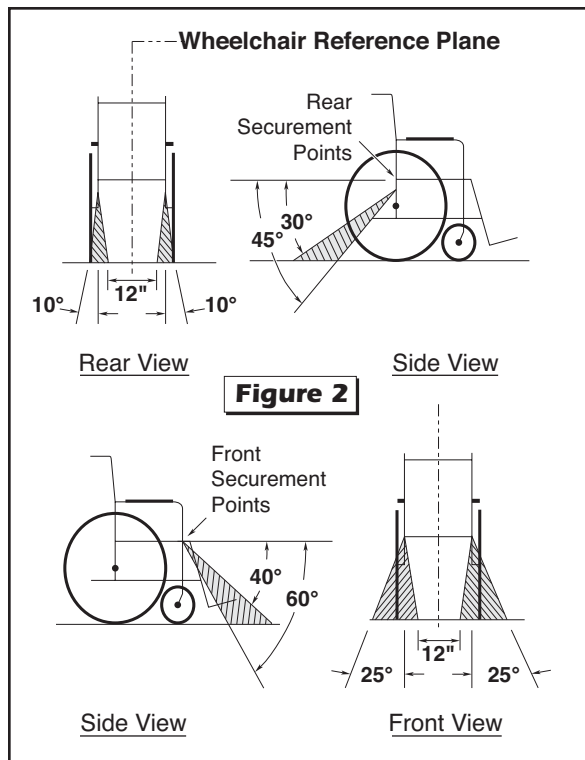

Restraint Belt Angles:

Locate wheelchair in forward-facing position centering wheelchair squarely within “L” track. The front and rear belts, when attached, should create angles approximately as shown in Figure 2. Preferred angles and locations of belts from wheelchair securement points to vehicle anchor points are shown. Front tie-downs should be angled out far for lateral stability when possible. **Note:** These are optimum angles and cannot be achieved in some cases.

Keeper Fitting and “L” Track Attachment Instructions:

The belts supplied in the Forward-Facing Wheelchair and Occupant Belt/Track System are equipped with keeper fittings (attachments) which engage the “L” track. Engage and release the keeper fittings as detailed and shown on page 25. **Note:** Lift to remove the “L” track plastic covers. Refer to pages 28 and 29 for belt attachment and release procedures.

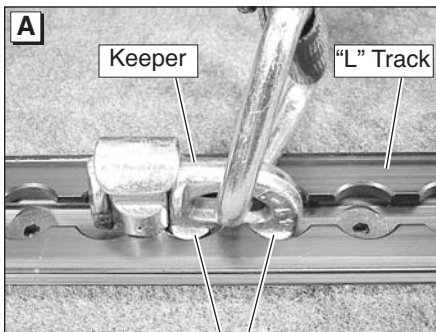

Align engagement feet with holes.

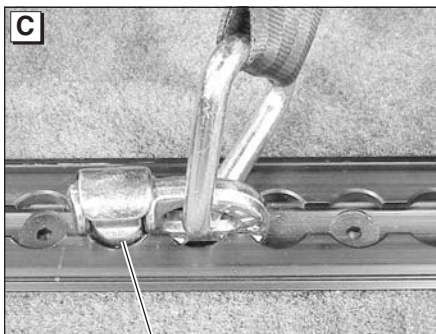

Fully-engaged Keeper

Keeper Fitting and “L” Track Attachment Instructions:

To Engage Keeper Fitting:

1. Insert keeper fitting into track (align two engagement feet with holes in track). See Photo A.
2. Push down on fitting and slide fitting 1/2 slot in either direction until it clicks and locks in position (see Photos B and C). Pull firmly on belt to ensure fitting is locked in track.

To Release Keeper Fitting:

- Lift plunger and slide fitting 1/2 slot in either direction and lift fitting out of track.

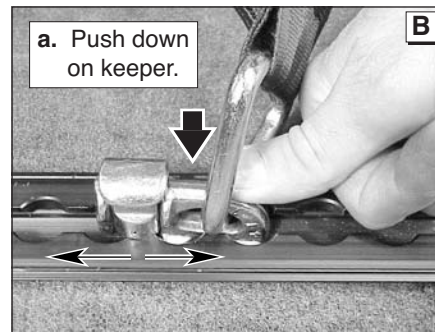

b. Slide keeper 1/2 slot in either direction.

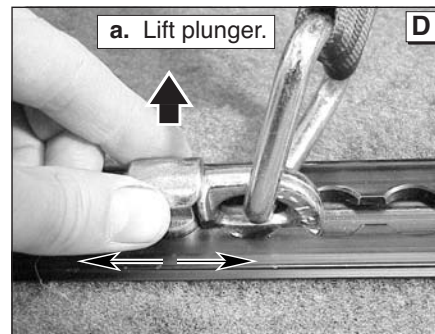

b. Slide keeper and lift.

WHEELCHAIR AND OCCUPANT RESTRAINT

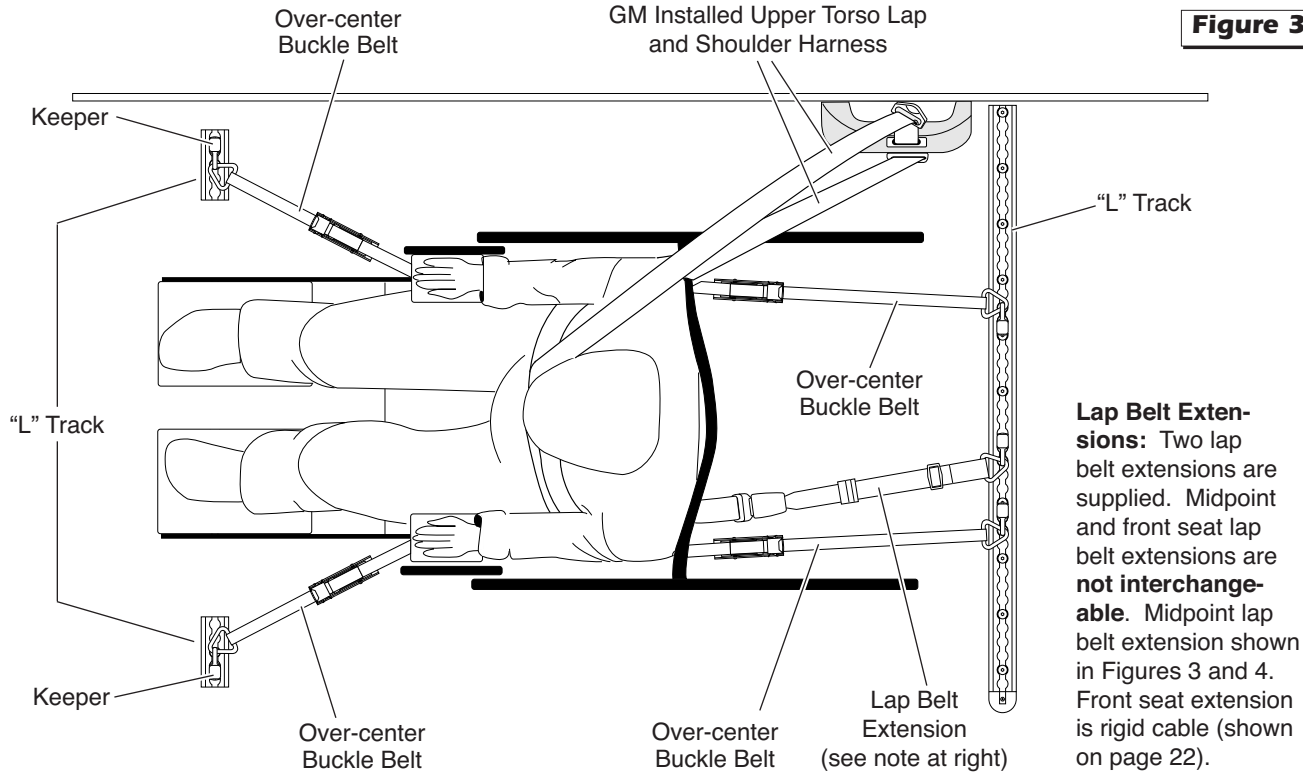

Figure 3

Lap Belt Extensions: Two lap belt extensions are supplied. Midpoint and front seat lap belt extensions are **not interchangeable**. Midpoint lap belt extension shown in Figures 3 and 4. Front seat extension is rigid cable (shown on page 22).

WHEELCHAIR AND OCCUPANT RESTRAINT

Note: Generic seat position shown. Attachment procedures are identical for all positions. Photos on pages 28 and 29 depict securement of wheelchair in midpoint position.

Keeper attachment details are provided on page 25.

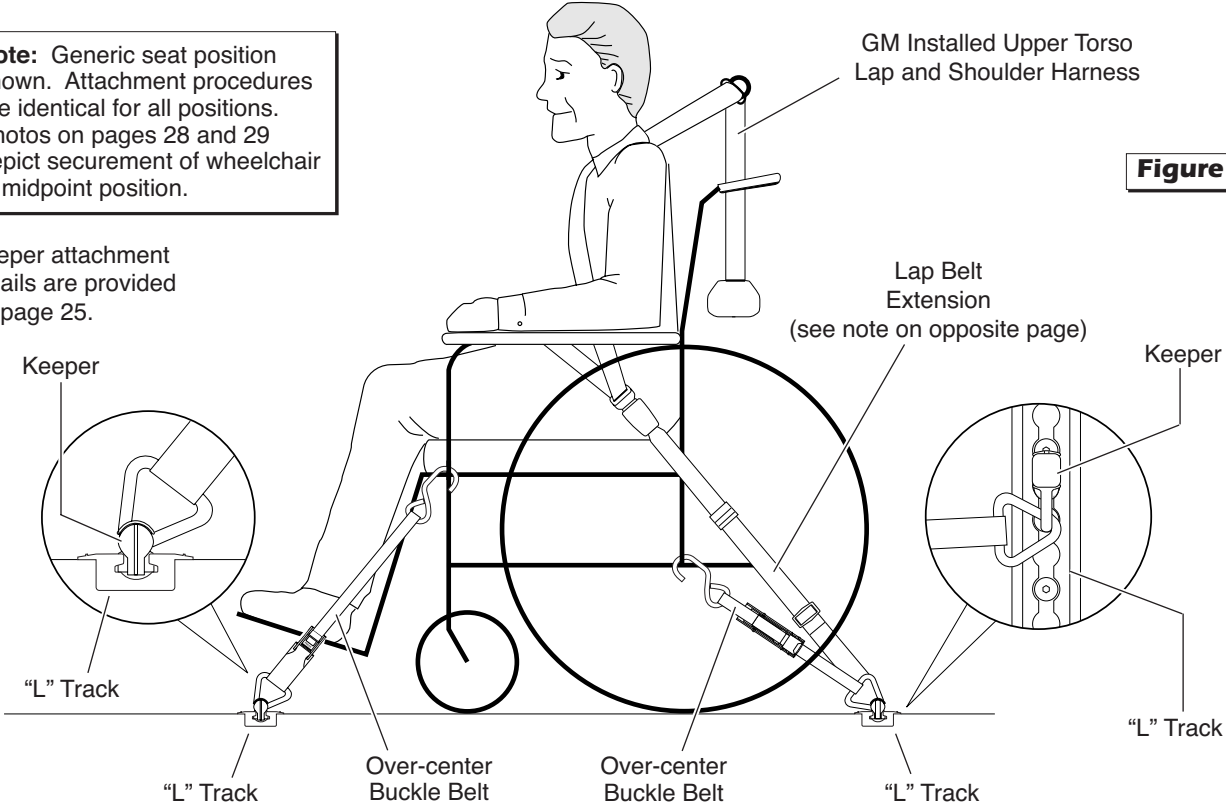
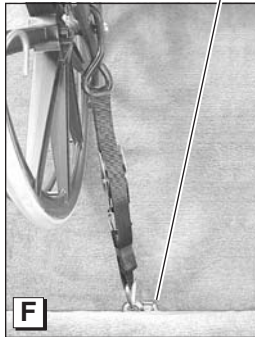

Figure 4

WHEELCHAIR AND OCCUPANT RESTRAINT



Hook
Keeper



Over-Center Belt Attachments

1. Connect chair hook to a solid frame member of the wheelchair (as shown in Photo E).

2. Position and connect belt keeper fitting (attachment) to appropriate track anchorage point (slots). Attach keeper as detailed on page 25.

Pull firmly on belt to ensure fitting is locked in track.

Note: Belt angles should be as shown in Figure 2.

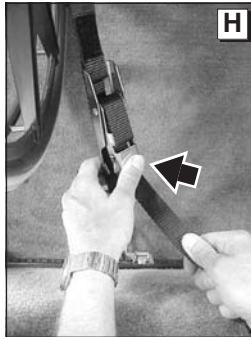
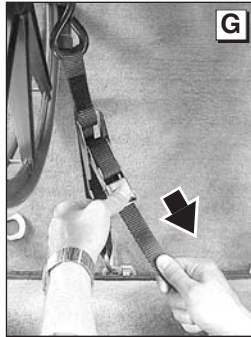

3. With buckle open, pull loose end of belt until tight (see Photo G). While holding the loose end with one hand, close the lever of the clamp (buckle) down until it locks. See Photo H.

4. Connect Velcro™ ▶ tabs to keep excess belt off floor. See Photo I).

Repeat procedures for all belts.

Note: Check to see that front and rear belts are tight and the chair is secure enough that it does not have any movement. Lock wheelchair brakes.

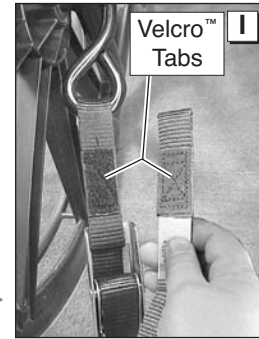

Belt Release: Press lever clamp (lock) to release tension on belt.





Lap Belt Extension

Lap Belt Extension

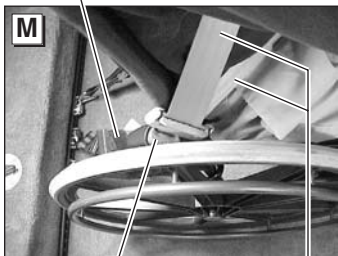

Receptacle

GM Lap and Shoulder Belt

Lap and Shoulder Belt Attachments

Refer to Photos K-N.

Note: Two lap belt extensions are supplied. The midpoint lap belt extension is an adjustable belt (shown in Photos K-N). The front seat extension is equipped with a rigid cable (nonadjustable - see photo on page 22). Lap belt extensions are **not interchangeable**. Attachment procedures are identical.

1. Position and connect the lap belt extension keeper fitting (attachment) to appropriate track anchorage point (slots). Attach keeper as detailed on page 25. Pull firmly on lap belt extension to ensure fitting is locked in track.

2. Connect the lap and shoulder belt to the lap belt extension (insert latch plate in female receptacle). Position the upper torso (shoulder) belt across the center of the shoulder. Position the lap belt low across the front of the pelvis (near hip). See Photos K-N.

Wheelchair occupant restraints should not be held away from the body by wheelchair components such as wheelchair armrests or wheels.

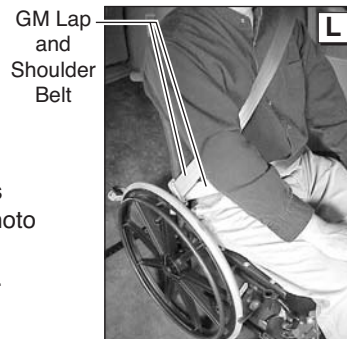

GM Lap and Shoulder Belt

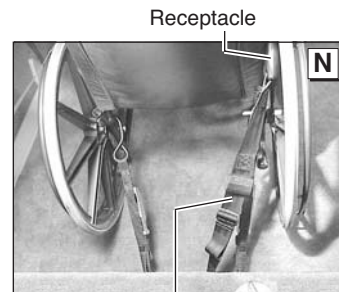

Receptacle

Lap Belt Extension

SEAT REMOVAL AND INSTALLATION

Front Seats: In an effort to produce vehicles that can be configured to meet a variety of customer needs, the driver and passenger seat bases have been designed so they may be removed. This feature allows the owner and sales representative to determine the appropriate seating arrangement to accom-

modate owner needs. Once the desired seat arrangement is determined, all power seat electrical harnesses must be reconnected to the appropriate fixed seat positions.

Entervan front seats are equipped with GM's quick-release seat attachments (making seat removal and installation procedures simple). The GM quick-release front seats are installed and removed as detailed in your GM owner's manual and on pages 34 and 35 of this manual.

Power Seats: Entervan front seats are equipped with electrical wiring harnesses to accommodate optional equipment such as heated seats, air bags, etc.
Before removing seats, be cer-

tain all seat electrical harnesses are disconnected.

When seats are removed, the seat electrical harness **plug must be connected to the receptacle** provided at the top of the seat base. See Photos A-D on page 31.

When positioning seats, it is **your responsibility** to reconnect all seat electrical harnesses. Failure to properly connect power seat electrical harnesses may result in power seat functions being disabled and/or the air bag light illuminating.

Contact your sales representative or call The Braun Corporation at 1-800-THE LIFT® if any of this information is not understood.

WARNING

Park vehicle and turn engine off before removing or installing seats. Failure to do so may result in serious bodily injury and/or property damage.



Seat Wiring Harness

Turn this knurled grip.

Receptacle

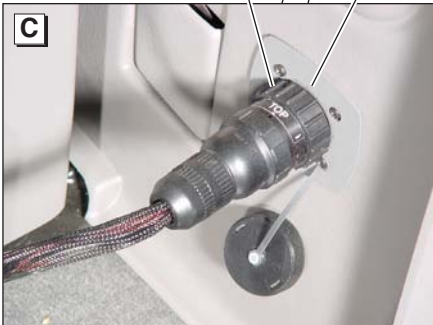

C

Front Seat Wiring Harnesses and Receptacles:

An electrical harness receptacle is located to the rear of each seat base in the wall (at “B” pillar). The seat wiring harness plug connects to the receptacle socket (screw-on connector details on pages 32 and 33).

Turn the seat harness connector large diameter knurled grip clockwise to connect (turn gripper nearest socket). See Photo C. Turn knurled grip counterclockwise to disengage connectors. Connect the seat electrical harness plug to the receptacle mounted to the top of the seat base when removing seat(s). See Photos B and D.



B

Seat Storage Receptacle



D

⚠ CAUTION

Disconnect seat wiring harness before removing seat. Failure to do so may result in property damage.

⚠ WARNING

Connect front seat wiring harness plug to socket provided at top of seat base before removing front seat. Failure to do so may result in serious bodily injury and/or property damage.

Front Seat Wiring Harnesses:

Entervan front seats are equipped with electrical wiring harnesses. See Photos A-D on page 31.

An electrical harness receptacle is located to the rear of each seat base in the wall (at “B” pillar). The seat wiring harness plug connects to the receptacle. **Before removing seats, be certain seat wiring harnesses are disconnected.**

When seats are removed, the **seat electrical harness plug must be connected to the receptacle** provided at the top of the seat base. When installing seats, **be certain seat wiring harnesses are reconnected.** Failure to do so may result in power seat functions being disabled and/or the air bag light illuminating.

Screw-on Connectors:

Front seat wiring harnesses are equipped with a screw-on connector (plug). Operate connectors as detailed here and on page 33.

A label is posted on the seat wiring harness plug which identifies the top of the connector (“TOP” decal 28891). Position the plug with the “TOP” label facing up when connecting the plug to either receptacle socket. Use this feature as an alignment guide.

Note: Alignment grooves (slots) are provided in receptacle sockets. Receptacle sockets have a single wider alignment groove that is positioned at 12 o’clock (shown on page 33). Seat wiring harness plugs are equipped with mating alignment guides (ears).

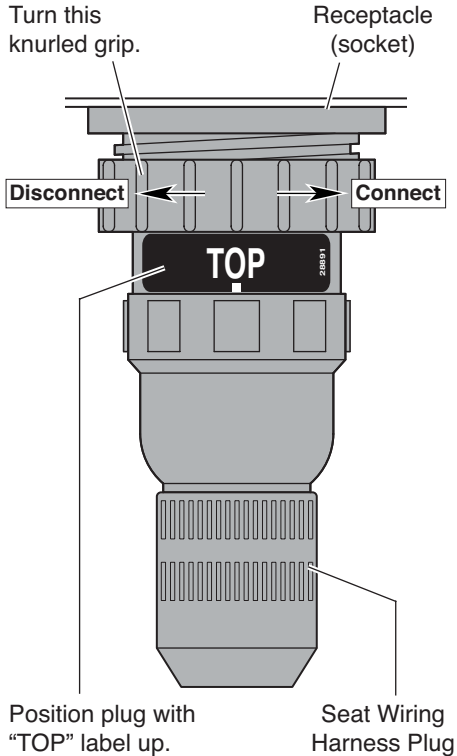

Screw-on Connectors:

To Connect: Align the seat harness connector by positioning the plug with the "TOP" label facing up. Align the seat harness connector alignment guides with the receptacle socket alignment grooves (will only connect one way).

Carefully insert the seat harness plug in the receptacle socket. Turn seat harness connector large diameter knurled grip clockwise fully (turn grip per nearest to socket).

To Disconnect: Turn seat harness connector large diameter knurled grip counterclockwise and disengage connectors.

Alignment Groove
(at 12 o'clock)

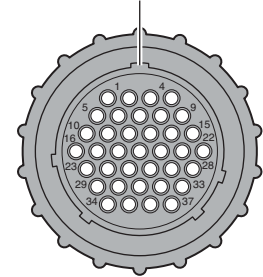

Receptacle Socket

Alignment Guide

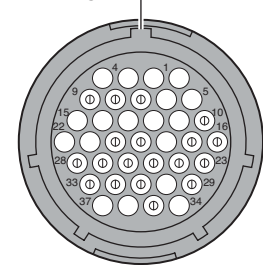

Seat Harness Plug

SEAT REMOVAL AND INSTALLATION

Quick-Release Front Seat Base

GM's quick-release seat base attachments engage recessed floor strikers (supports). A release strap is located at the rear of the seat base (see Photo E). Pulling the release strap disengages the attachments and allows easy removal of the seats.

Tip rear of seat backwards and roll seat base out of vehicle as shown. **Note:** Push top of seat forward while pulling strap for easier disengagement.

Caution: Do not contact the ramp when reclining or moving seats. Doing so may result in property damage.

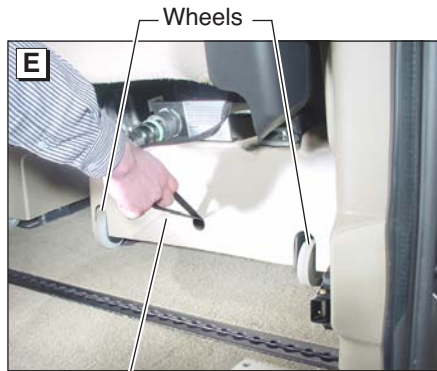

Pull release strap.



Tip seat back



and roll out of vehicle.

Front Seat Removal Instructions

1. **Disconnect seat wiring harnesses before removing seats.** See pages 30-33 for wiring harness details and photos. **Connect harness to receptacle** provided at top of seat base (see Photos B and D on page 31).
2. Pull the release strap (loop) located at the rear of the seat

CAUTION

Disconnect seat wiring harness before removing seat. Failure to do so may result in property damage.

base (see Photo E on page 34). Seat base will release from floor supports. **Note:** Push top of seat forward while pulling strap for easier disengagement.

3. Tip rear of seat backwards and roll seat base out of vehicle. See Photos F and G on page 34.

Front Seat Installation Instructions

1. Roll seat base into position (aligning the seat base attachments with the recessed floor strikers).
2. Push seat down and forward to latch the front seat attachments with the recessed floor strikers (receptacles) first. Once the front is latched fully, push

downward on the rear of the seat to latch the rear seat attachments. **Be sure the seat is fully latched in floor supports** before occupying seat or operating vehicle.

3. Connect (plug) the electrical harness sockets. See pages 30-33 for details.

WARNING

Seat attachments must be fully latched in floor supports before occupying seats or operating vehicle. Failure to do so will result in serious bodily injury.

SEAT REMOVAL AND INSTALLATION

Third Row Seats:

The OEM third row seats have been modified to lower the cushion height to accommodate passengers comfortably with the lowered floor of the Entervan. The lowered third row seats are removed and installed following the procedures outlined in the OEM owners manual.

The modifications to lower the OEM third row seats decrease the folding range of the seat backs. Before modifications, the OEM third row seats lie flat when the seat backs are folded down. The modified (lowered) seats are restricted and will not lie flat (as depicted in the photos at right).



View from Rear of Modified
Third Row Seat (in folded position)



View from Front of Modified
Third Row Seat (in folded position)

□ In accordance with the GM 6 year/100,000 mile corrosion warranty, The Braun Corporation warrants to the purchaser of its Entervan conversion that the metal fabrication on or of the frame, floor and lowered door extension are free from defects in material and factory workmanship for a period of 6 years or 100,000 miles on the odometer, whichever occurs first. The Braun Corporation further warrants to the purchaser that the remainder of the modifica-

tions and alterations for associated parts are free from defects in material and workmanship for a period of 36 months or 36,000 miles, whichever comes first. For clarification purposes, the following chart outlines The Braun Corporation Entervan warranty coverage. Refer to your GM warranty information booklet for all GM OEM (factory) limited warranty details.

Years/Miles in Service	Specific Area Covered
<p style="text-align: center;">36 Months or 36,000 Miles (whichever comes first)</p>	<p>Entervan frame and floor structural components</p> <p>Entervan ramp, door and associated structural components</p> <p>Entervan electrical components including but not limited to switches, wires, connectors and the controller</p> <p>Entervan electromechanical kneel systems including but not limited to electric actuator, chain, pulleys and associated hardware</p>

WARRANTY

Years/Miles in Service	Specific Area Covered
<p>36 Months or 36,000 Miles (whichever comes first)</p>	<p>Entervan appearance items including but not limited to interior floor covering and slide door lowered extension assemblies.</p>
<p>Corrosion Warranty</p> <p>Outer Panels</p> <p>6 Year or 100,000 Miles (whichever comes first)</p> <p>All Panels (Exceptions)</p> <p>3 Year or 30,000 Miles (whichever comes first)</p>	<p>Corrosion Warranty:</p> <p>Outer Panels: Entervan frame, floor and lower door modification metal fabrication corrosion applies to perforation only. Entervan lower slide door modification corrosion applies to outer-body sheet metal and paint. Perforation is a rust-through condition such as an actual hole in the metal.</p> <p>All Panels (Exceptions): Cosmetic or surface corrosion (resulting from stone chips for example) would not be covered or repaired under this coverage. If corrosion does not cause holes, and is not the result of usage and/or environmental conditions, repair coverage lasts for 3 years or 36,000 miles, whichever comes first.</p>

Both the 6 year/100,000 mile corrosion and the 3 year/36,000 mile warranties described on previous page commence on the date the conversion is put into service, providing the warranty registration card is completed and received by The Braun Corporation within thirty days of the purchase.

The Braun Corporation agrees to repair or replace any of its Entervan factory-installed parts found to be defective within the appropriate warranty period or mileage. This warranty also covers the cost of labor for the repair or replacement of said parts for one year provided that the repair is authorized by The Braun Corporation and carried out by an authorized service establishment (a Braun labor schedule determines the cost allowance for repairs). The Braun Corporation will not honor any warranty claim for repairs or replacement of parts unless the claim is submitted with the appropriate factory warranty authorization data and the repairs or replacement of the parts are completed by a factory-authorized repairman. The factory authorization data, together with the name and location of the factory-authorized repairman, can be obtained by

either written or telephone contact with The Braun Corporation at the addresses appearing in this manual.

The return authorization procedure must be adhered to in order to process any warranty and repair claims (details on following page).

The Braun Corporation reserves the right to designate where any warranty work is to be performed.

The Braun Corporation also reserves the right to examine any defective workmanship or part prior to any authorization of necessary repairs. This Entervan warranty is not intended to replace or substitute any other warranties issued by the original manufacturer of the vehicle or other suppliers of components. This warranty shall not apply to any part or workmanship that may become defective due to misuse, neglect, accident or other casualty, modifications or alterations or unauthorized repairs. Further, this warranty shall not extend to parts or workmanship that may become defective because of the failure of

WARRANTY

anyone to operate the same in accordance with the printed instructions of The Braun Corporation or because of operation of the same beyond its capacity.

This warranty does not cover normal maintenance, service, or periodic adjustments necessitated by use or wear.

Second buyers of a Braun Entervan conversion may transfer the remaining warranty, if any, by obtaining a transfer of warranty application from The Braun Corporation. This application must be returned to The Braun Corporation within thirty days

from the date you purchase the vehicle and proof of the date of purchasing must be supplied with the transfer of warranty application. There will be a minimum warranty transfer fee.

The Braun Corporation shall not be liable for any incidental or consequential damages resulting from any breach of warranty.

The Braun Corporation shall not be liable for towing charges, travel and lodging, or any other expense incurred due to the loss of use of vehicle or other reason.

RETURN AUTHORIZATION PROCEDURE

When processing any warranty claims (parts, repairs, etc.), all requests must be processed through The Braun Corporation Product Support Department. Call 1-800-THE LIFT® during working hours. Product Support will issue a Return Material Authorization (RMA) number and detail the procedures

required for processing returns and/or authorizing credit.

The last eight digits of the vehicle identification number (VIN) **must be provided when filing a warranty claim or ordering parts.**

Maintenance is necessary to ensure safe and trouble-free Entervan operation. General preventive maintenance consisting of inspections of your Entervan systems along with cleaning and lubricating procedures should be a part of your routine (lubrication requirements are minimal). Regular preventive maintenance procedures will increase the service life of the Entervan, as well as enhance safety.

During routine inspections, operate all Entervan systems and note the following (as equipped):

- Is the power source adequate or weak?
- Does the electronic control system function properly?
- Do the control switches function properly?

- Does the power door function properly?
- Does the ramp unfold and fold properly?
- Inspect wheelchair and occupant restraint belts, buckles and hardware for damage, wear, abnormal condition or improper operation.

Entervan ramps are equipped with sealed bearings and Teflon™ bushings to decrease wear, provide smooth operation and extend the service life of the ramp. These components do not require lubrication under normal conditions (although the ramp should be inspected and cleaned routinely).

Light oil should be applied to the outboard ramp extension hinge. Clean the components and the

surrounding area before applying lubricants. LPS2 General Purpose Penetrating Oil is recommended by and available from the Braun Corporation (part number 15807). Use of improper lubricants can attract dirt or other contaminants which could result in wear or damage to components.

Clean and lubricate the specified points approximately every four weeks or 100 cycles. These intervals are a general guideline and will vary according to frequency of use and conditions. Exposure to severe conditions (weather, environment, heavy usage, etc.) may require inspection and maintenance procedures to be performed more often.

PREVENTIVE MAINTENANCE / JACKING AND TIRE CHANGING

Preventive maintenance visual inspections, cleaning and lubrication procedures **do not** take the place of the procedures specified in the Maintenance and Lubrication Schedule provided in the Entervan service manual. The

WARNING

Maintenance and lubrication procedures must be performed by authorized service personnel as specified in the applicable Entervan service manual. Failure to do so may result in serious bodily injury and/or property damage.

procedures outlined in the Maintenance and Lubrication Schedule **must be performed at the recommended scheduled intervals by an authorized Braun Corporation service representative who has attended and been certified by The Braun Corporation Sales and Service School.**

If there is any sign of damage, wear, abnormal condition or improper operation, **discontinue Entervan use immediately.** Contact your sales representative or call The Braun Corporation at 1-800-THE LIFT®. One of our Product Support representatives will direct you to an authorized service technician who will inspect your Entervan.

Jacking and Tire Changing

Interior Spare Tire Mount: The spare tire is mounted behind the third row seats. The jack and tire changing tools are located in the storage compartment at the rear of the vehicle, on the passenger's side (OEM storage location).

Jacking and Tire Changing

Procedures: Jacking and tire changing procedures have not been affected by the conversion. Detailed tire changing instructions are provided in the GM-supplied owner's manual.

Refer to the GM-supplied manual for tire changing instructions and safety precautions, as well as instructions regarding other roadside emergencies.

AUXILIARY POWER SUPPLY / BELOW FLOOR OBSTRUCTIONS / WELDING

Note: The technical information provided on pages 43-49 of this manual is service related. If you are having an electrical tie-down, power seat or other auxiliary electrical device installed in your Entervan, this information should be supplied to the technician. Otherwise, disregard this section.

Auxiliary Power Supply: Do not connect auxiliary devices directly

⚠ CAUTION

Do not connect auxiliary devices to vehicle battery. Doing so may result in damage to electrical system and/or electronic components.

to the vehicle battery. Doing so **may result in damage to electrical system and/or electronic components.**

Three fuse blocks are available for use as an auxiliary power source for dealer-installed auxiliary electrical device(s). Fuse block details and specifications are provided on pages 44 and 45.

Below-Floor Obstructions: When installing aftermarket equipment in an Entervan, obstructions below the floor must be avoided. Obstructions include wiring, fuel system, brake lines, etc. Installers must be aware of these obstructions. Refer to the illustration on page 47 to avoid contacting or damaging vital components under the floor.

Welding: In the event that welding is required when installing aftermar-

ket equipment, follow the safety precautions provided on page 48.

⚠ WARNING



**Risk of electrical fire!
Install and electrically terminate auxiliary electrical device as specified by device manufacturer.**

Auxiliary Power Supply

Do not connect auxiliary devices directly to the vehicle battery. Doing so **may result in damage to electrical system and/or electronic components.**

Three fuse blocks are available for use as an auxiliary power source. Fuse block specifications are provided on page 45.

One Ignition fuse block and one Battery fuse block are located just below the glove box (behind the passenger side A-pillar interior panel). An additional Battery fuse block is located at the rear of the vehicle. Access the fuse blocks as detailed at right.

A-Pillar Fuse Block Access

Remove the front passenger seat assembly (seat removal instructions on pages 30-35). Disengage the passenger door weather strip around the A-pillar. Bend back the A-Pillar interior panel to expose the fuse blocks as shown below (fuse block details on page 45).

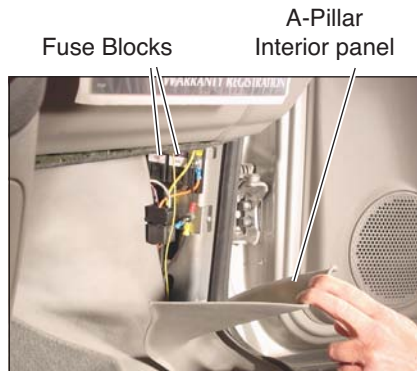

Rear Fuse Block Access

The Entervan electronic controller is located inside the rear passenger side OEM jack storage compartment. Open the OEM access door (shown below). The fuse block is mounted on the electronic controller mounting bracket (fuse block illustration on page 45).



AUXILIARY POWER SUPPLY / BELOW FLOOR OBSTRUCTIONS / WELDING

Fuse Blocks: Three fuse blocks are available for use as an auxiliary power source (one **Ignition** fuse block and two **Battery** fuse blocks).

Battery fuse blocks provide power at all times (independent of the vehicle ignition). The Ignition fuse block supplies power when the vehicle ignition is on only.

Each fuse block can accommodate additional ATO® type fuses in the slots marked **open** (specifications at right).

The **installer is responsible for supplying the correct gauge wire and fuse** for the particular device to be attached to the fuse block (**as specified** by the manufacturer of the device).

Fuse Specifications:

A-Pillar Fuse Blocks: The **total maximum load** of all fuses installed in the A-Pillar Ignition fuse block **must not exceed 20 amperes**. The **total maximum load** for the A-pillar fuse blocks (**combination of Ignition block and Battery block**) **must not exceed 50 amperes**.

Rear Fuse Block: The **total maximum load** for the Rear Battery fuse block **must not exceed 50 amperes**.

Note: If installing an auxiliary electrical device that requires more than a 50 ampere power source, an alternative power source must be provided.

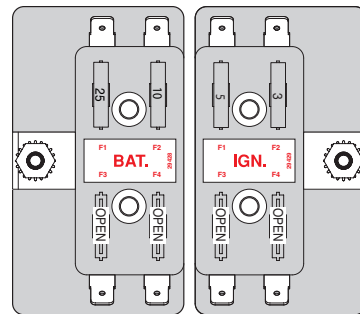

A-Pillar Fuse Blocks

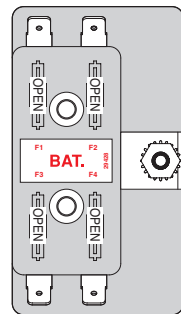

Rear Fuse Block

Below-Floor Obstructions

When installing an electrical tie-down, power seat or other auxiliary electrical device in an Entervan, obstructions below the floor must

be avoided. Obstructions include wiring, fuel system, brake lines, etc. Installers must be aware of these obstructions.

Refer to the illustration on the following page when installing aftermarket equipment to avoid contacting or damaging vital components under the floor. **Drilling or cutting into such obstructions may result in potential hazards as well as property damage.**

Note: Some wiring harnesses shown may not be present. Avoid all harness locations.

⚠ WARNING

Check for obstructions such as wires, gas lines, exhaust, etc. before drilling or cutting through floor. Failure to do so may result in serious bodily injury and/or property damage.

⚠ WARNING



Risk of electrical fire! Install and electrically terminate auxiliary electrical device as specified by device manufacturer.

AUXILIARY POWER SUPPLY / BELOW FLOOR OBSTRUCTIONS / WELDING

Below-Floor Obstructions

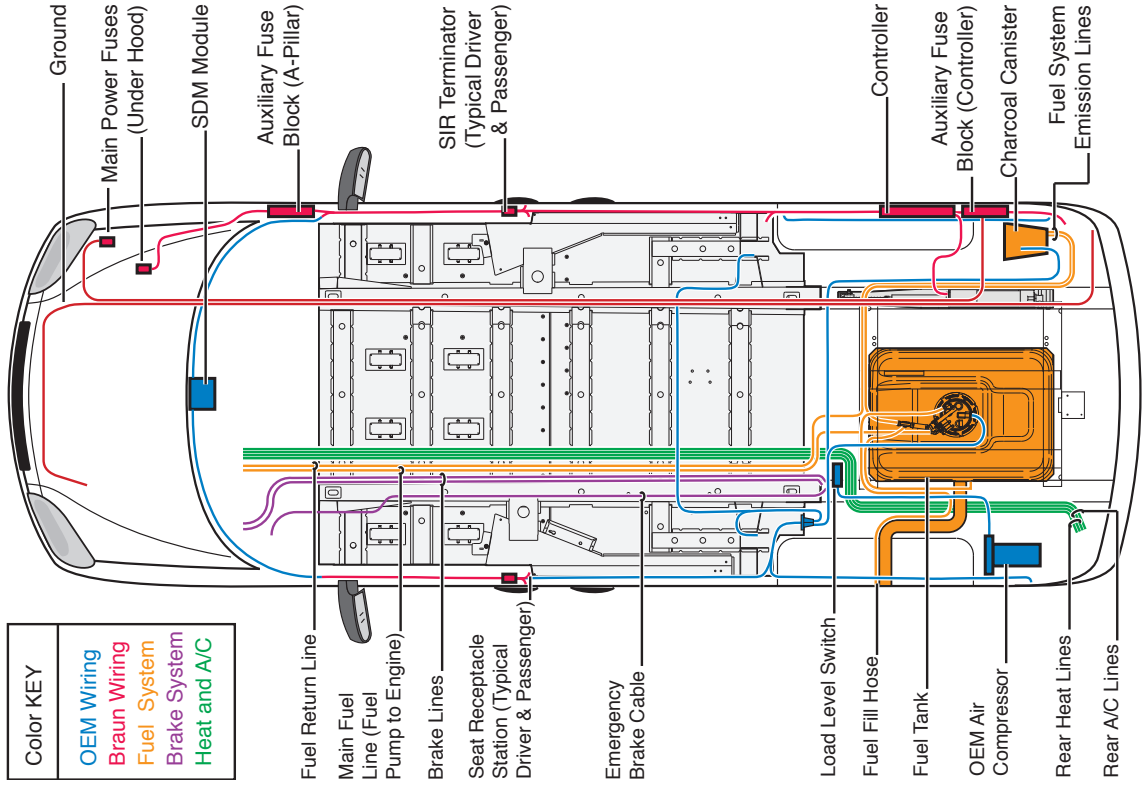

Welding Precautions:

To avoid damaging the OEM and the Braun electrical systems or components during welding procedures, practice the following precautionary measures:

- Do not route welder electrical cables on, near or across any vehicle electrical wiring or components while welding is in progress.
 - Remove or adequately shield any electrical or electronic components which can be damaged by excessive temperatures created by the welding operation.
 - Protect all wiring and electrical components from damage that can be caused by welding flash (sparks).
 - Make sure that the welder ground clamp is of an adequate size and placed as close as possible to the area being welded. Never use a vehicle suspension component as a welding ground point.
- Prior to any welding, disconnect all negative (ground) cable(s) from all battery(ies).
 - Disable the air bag system as outlined in “Air Bag (SIR) Precautions” section of the OEM service manual.
 - Disconnect any electrical/electronic computer modules located near the area to be welded.

After the welding is complete, carefully inspect any electrical wiring or components in the weld area for degradation or damage.

OEM Fuses and Circuit Breakers

The wiring circuits in your Entervan are protected from short circuits by a combination of fuses, circuit breakers and fusible thermal links. Refer to your OEM owner's manual for details regarding the OEM fuses.

Entervan (Braun Conversion) Fuses

Interior Fuses: Your Entervan conversion is equipped with one Ignition fuse block and one Battery fuse block located just below the glove box (behind the passenger side A-pillar interior panel). An additional Battery fuse block is located at the rear of the vehicle. Details and specifications for these fuse blocks are provided on pages 44 and 45.

Engine Compartment Fuses: A 50 ampere fuse is located below right of the OEM underhood fuse block. See photo below. A 60 ampere fuse is located above the vehicle battery. If you experience a power failure with the Entervan power door, ramp or kneel system, check the 60 ampere fuse and the 50 ampere fuse in the engine compartment.

If the engine compartment 50 and 60 ampere fuses are good, check the fuses at the A-Pillar location. Access the A-Pillar fuse blocks as detailed on page 44. If all fuses are good, contact your sales representative or call The Braun Corporation at 1-800-

THE LIFT®. One of our Product Support representatives will direct you to an authorized service technician who will inspect your Entervan.

Note: Replacement fuses **must** be of identical size and rating.



REPORTING SAFETY DEFECTS

Reporting Safety Defects to the United States Government

If you believe that your vehicle has a defect which could cause a crash or could cause injury or death, you should immediately inform the National Highway Traffic Safety Administration (NHTSA) in addition to notifying the Braun Corporation.

If NHTSA receives similar complaints, it may open an investigation, and if it finds that a safety defect exists in a group of vehicles, it may order a recall and remedy campaign. However, NHTSA cannot become involved in individual problems between you, your dealer or the Braun Corporation.

To contact NHTSA, you may either call the Auto Safety Hotline toll-free at 1-800-424-9393 (or 366-0123 in Washington, D.C. area) or write to:

NHTSA, U.S. Department of Transportation
Washington, D.C. 20590

You can also obtain other information about motor vehicle safety from the Hotline.

Reporting Safety Defects to The Braun Corporation

In addition to notifying NHTSA we certainly hope you will notify us. Please call us at 1-800-THE-LIFT®, or write:

The Braun Corporation
631 West 11th Street
P.O. Box 310
Winamac, IN 46996 USA

"Providing Access to the World"®



**Over 300 Braun
Dealers Worldwide**

BRAUN



CONSUMER

Foldout Ramp

Operator's Manual

ENTERVAN®

**Wheelchair-Accessible
Lowered Floor Conversion
featuring 2005 and Newer
GM Minivans**

**THE BRAUN
CORPORATION®**

"Providing Access to the World"®

International Corporate Hdqrs: P.O. Box 310 Winamac, IN 46996 USA
1-800-THE LIFT® (574) 946-6153 FAX: (574) 946-4670
braunmobility.com™ entervan.com™



31913 Rev A
January 2005

Patent # 6,825,628 B2
Patent Pending

All illustrations, descriptions and specifications in this manual are based on the latest product information available at the time of publication. The Braun Corporation reserves the right to make changes at any time without notice.

Foldout Ramp Entervan®
featuring GM Minivans