

Service Manual for:
NUVL603C
Under-Vehicle Lift®



Private Use Wheelchair Lifts

Series 02

DOT — Private Use Lift

“DOT — Private Use Lift” verifies that this platform lift meets only the “private use lift” requirements of FMVSS No. 403. This lift may be installed on all vehicles appropriate for the size and weight of the lift, except for buses, school buses, and multi-purpose passenger vehicles other than motor homes with a gross vehicle weight rating (GVWR) that exceeds 4,536 kg (10,000 lb).

 **THE BRAUN CORPORATION**
“Providing Access to the World”®

International Corporate Hdqrs: P.O. Box 310 Winamac, IN 46996 USA
1-800-THE LIFT® (574) 946-6153 FAX: (574) 946-4670



WARNING

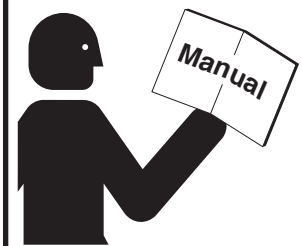

Read manual before installing or servicing lift. Failure to do so may result in serious bodily injury and/or property damage.

Braun UVL Series™

Congratulations

We at The Braun Corporation wish to express our fullest appreciation on your new purchase. With you in mind, our skilled craftsmen have designed and assembled the finest lift available.

This manual provides service-related material. Refer to the FMVSS No. 403 Quick Reference Installation Sheet for installation instructions, operating instructions and maintenance procedures.

Braun UVL Series™ lifts are built for dependability and will provide years of pleasure and independence as long as the lift is installed and serviced as specified by a Braun certified technician, and the lift is operated by an instructed person.

Sincerely,
THE BRAUN CORPORATION



Ralph W. Braun
Chief Executive Officer

Warranty and Registration Instructions

Immediately upon receiving the lift, examine the unit for any damage. Notify the carrier at once with any claims.

Two warranty/registration cards (shown right) are protected in a clear envelope and attached to the lift protective shipping wrap. The sales representative must process one of the cards. The consumer must fill out the other card and mail it to The Braun Corporation. A detailed warranty section is provided in this manual. The warranty cards must be processed to activate the warranty.

Model No. Serial No.

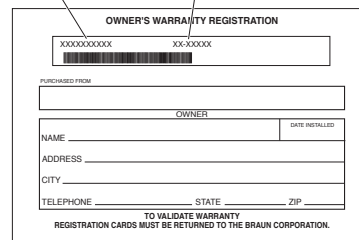

OWNER'S WARRANTY REGISTRATION

XXXXXXXXXXXX XXXXXXXX

PURCHASED FROM

OWNER

NAME _____ DATE INSTALLED _____
ADDRESS _____
CITY _____
TELEPHONE _____ STATE _____ ZIP _____

TO VALIDATE WARRANTY
REGISTRATION CARDS MUST BE RETURNED TO THE BRAUN CORPORATION.

Sample Warranty/Registration Card

Two Braun Serial No./Series No. identification tags (shown below) are posted on the lift. One I.D. tag is posted on the left platform side plate (outboard end). A second I.D. tag is located inside of the pump module. Both I.D. tags provide the product identification information provided on the warranty/registration card. Record the information in the space provided (or document on a copy). This information must be provided when filing a warranty claim or ordering parts.

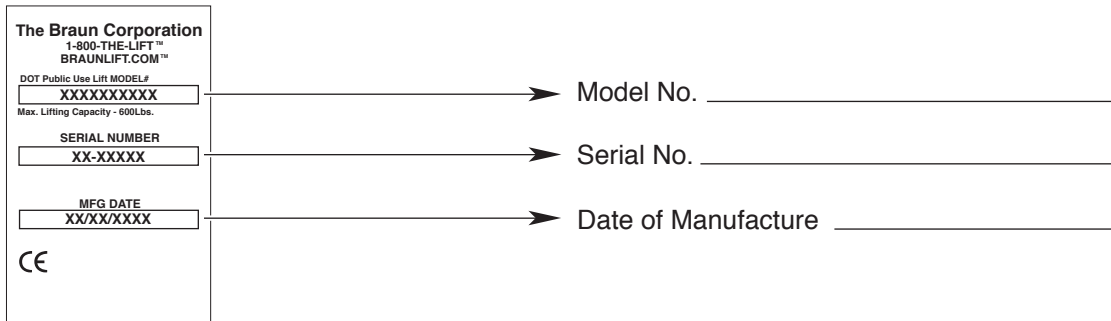

The Braun Corporation
1-800-THE-LIFT™
BRAUNLIFT.COM™

DOT Public Use Lift MODEL#
XXXXXXXXXXXX

Max. Lifting Capacity - 600Lbs.

SERIAL NUMBER
XX-XXXXX

MFG DATE
XX/XX/XXXX

CE

→ Model No. _____

→ Serial No. _____

→ Date of Manufacture _____

Sample Serial No./Series No. Identification Tag

Contents

Troubleshooting and Maintenance

Lift Terminology	2
Switch and Sensor Locations	3
Certification Checklist Diagnostic Procedures	4
Adjustments and Calibration	5
LCD Diagnostic Codes	6
Floor Level and Inboard Locator Adjustments	7-10
Lubrication Diagram	11
Maintenance and Lubrication Schedule	12-14
Troubleshooting Diagnosis Chart	15-17
Lift Accessories Wiring Schematic	18
Lift Wiring Schematic	19A, 20A
Contact Removal	19B

Hydraulics

Hydraulics Parts List	20B
Hydraulics Diagram	21

Repair Parts

Pump Module

Pump Module Parts List	22
Pump Module Diagram	23A, 24A

Lift Exploded Views

Complete Lift	23B, 24B
Repair Parts List	25
Housing Detail.....	26
Carriage Detail.....	27
Platform Detail	28

Warranty

Braun® Limited Warranty	29-31
-------------------------------	-------

Lift Terminology

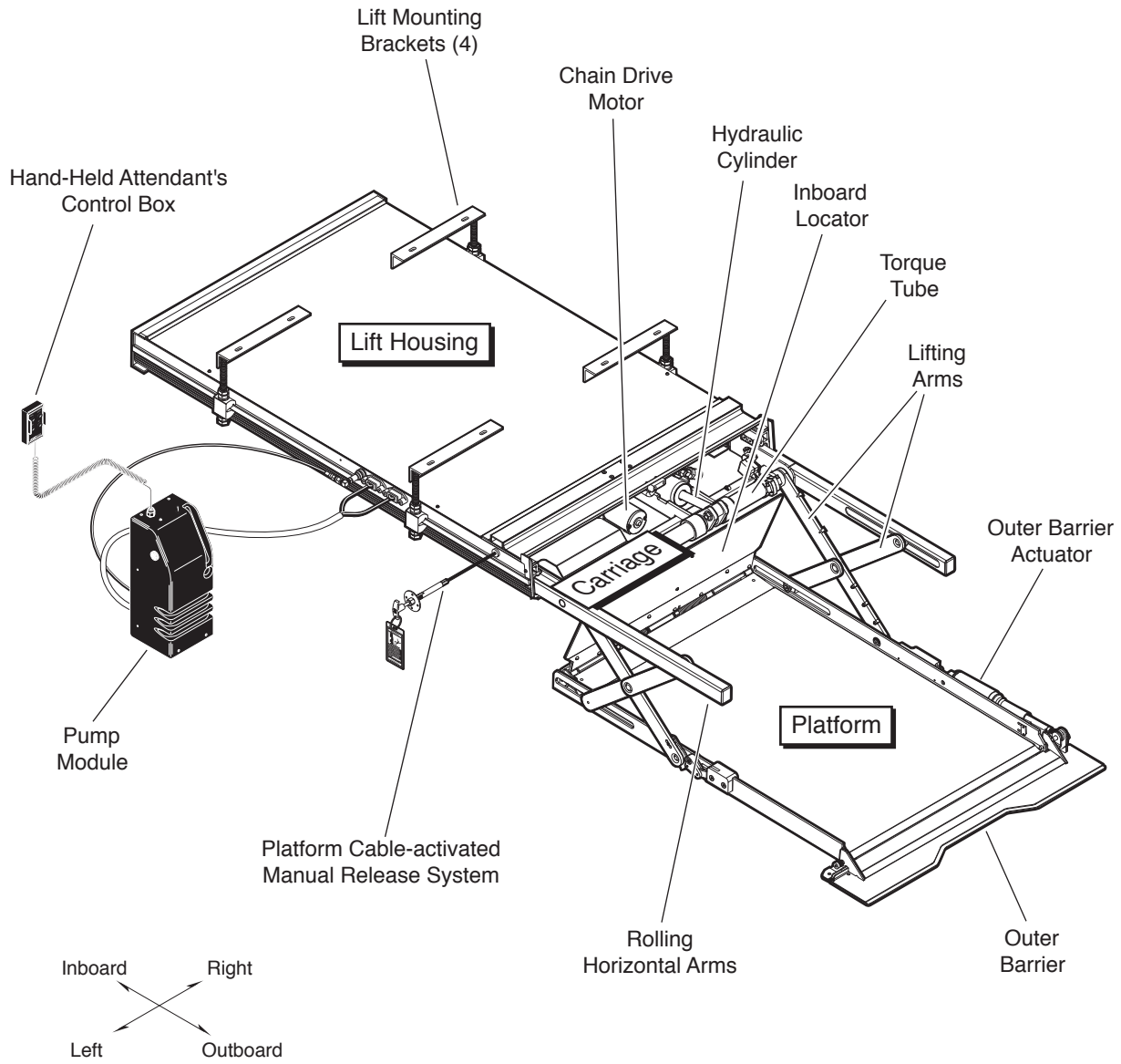

Switch and Sensor Locations

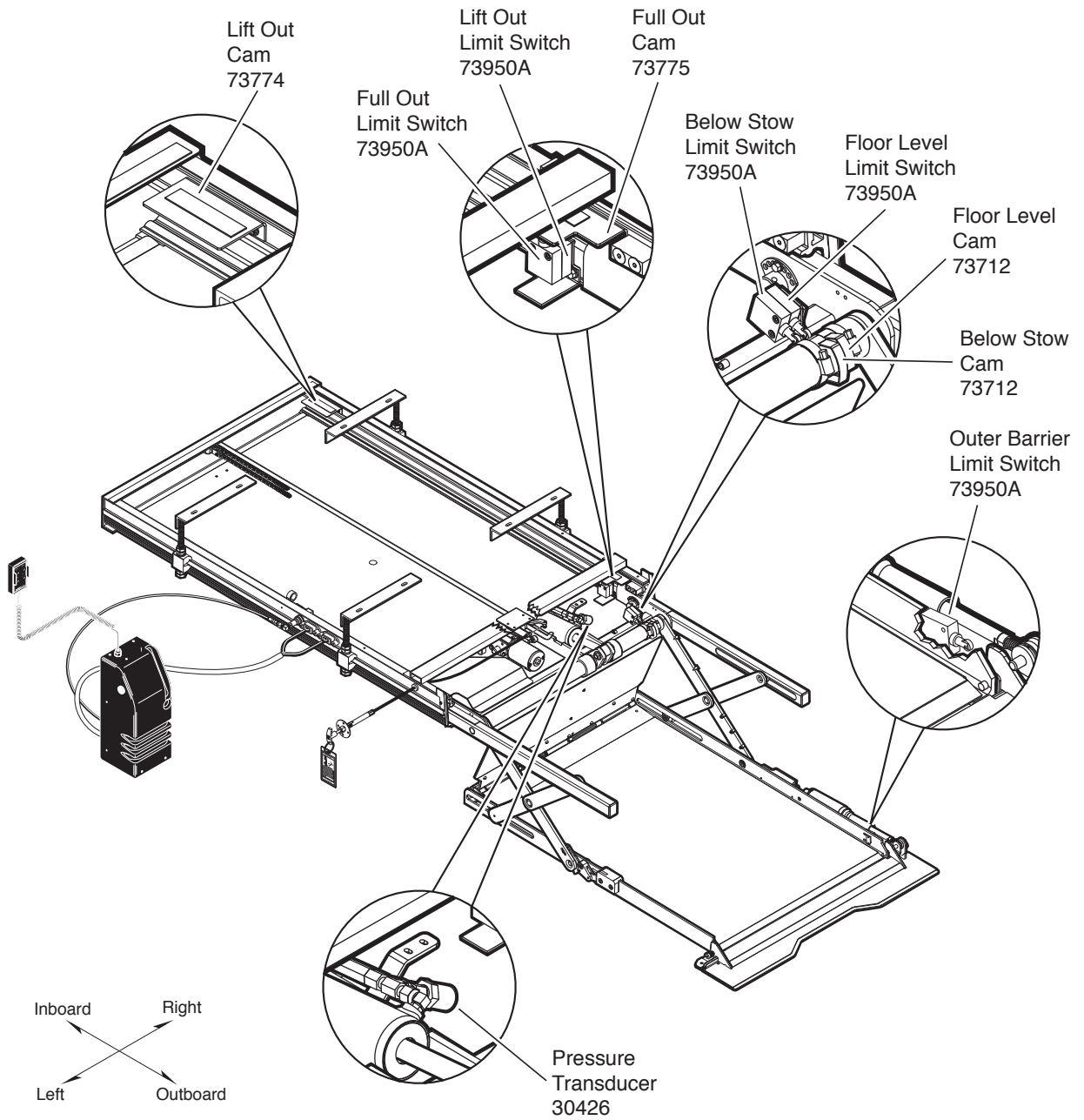

Certification Checklist Diagnostic Procedures

The following operations and conditions must be functionally verified in order for the lift to be FMVSS 403/404 compliant. If an operation does not function as described or a condition is not met, follow the referenced procedures to correct the problem or contact a Braun Corporation Product Support representative.

- Vehicle movement is prevented unless the lift door is closed, ensuring the lift is stowed.
 1. Verify lift stowed signal (pin 9) in the 9 conductor plug on the side of the pump module has a +12 volt signal.
 2. Refer to the interlock installation instructions.

- Lift operation shall be inhibited unless the vehicle is stopped and vehicle movement is prevented.
 1. Verify vehicle secure signal (pin 6) in the 9 conductor plug on the side of the pump module has a +12 volt signal.
 2. Refer to the interlock installation instructions.

- The platform will not fold/stow when occupied.
 - Refer to Platform Sense Calibration.

- The inboard locator will not fold/stow if occupied.

- The outer barrier will not raise if occupied.
 - Refer to Outer Barrier Occupied Calibration procedure

- An audio warning (and visual warning for public use lifts) will activate if the threshold area is occupied when the platform is a least 1" below floor level.
 1. Make sure connectors to threshold mat are properly connected.
 2. Call Product Support.

- Platform movement shall be interrupted unless the outer barrier is deployed (up).
 - Check Barrier Down limit switch, wires and connector.
 - Diagnostic LCD should display a value of "1" for OBAR SW when outer barrier is deployed (up).

Adjustments and Calibration

Adjustment Procedures

Lift Out Switch: The Lift Out Switch stops inward travel of the carriage/platform during Stow function (activated by the housing-mounted Lift Out Cam). Move cam in to increase inward travel. Move cam out to decrease inward travel.

Full Out Switch: The Full Out Switch stops outward travel of the carriage/platform during Deploy (Up/Down) functions (activated by the housing-mounted Full Out Cam). Move cam in to decrease outward travel. Move cam out to increase outward travel. Carriage rollers must be inside housing a minimum 1/2". The platform will not raise or lower until this switch is activated.

Floor Level Switch: See page 7 for procedures.

Stow Switch: The Stow Switch controls the height of the carriage/platform before it moves inward during the Stow function (activated by the torque tube-mounted Stow Cam). Rotate the cam in to decrease platform height. Rotate the cam out to increase platform height. Adjust cam so lifting arms are aligned. View the platform position in the housing.

Barrier Down Switch: This platform-mounted switch prohibits the platform from raising unless the outer barrier is in the full up position. The Up function is prohibited if the outer barrier detent pin is not fully engaged also.

Drive Chain Adjustment

In event the drive chain sags 13 mm (1/2") or more, adjust tension as detailed. Tighten to eliminate visible sag but do not overtighten.

1. Unlock and pull the manual release cable and lock in the released position.
2. Manually extend platform carriage 2/3 full out.
3. Remove adjustment bolt (tensioner) access cover.
4. Use deep well socket (long key sleeve) to loosen outside jam nut. Tighten inside jam nut to eliminate visible chain sag but do not overtighten.
5. Lock jam nuts together. Unlock and push the manual cable in fully. Lock release cable. Move the platform in and out until platform chain release assembly engages chain.

Carriage Ride Height Adjustment

The carriage horizontal arms move (roll) in and out of the housing tracks on roller bearings. Following installation or extensive lift operation, clearance between horizontal arms and tracks may diminish. The eccentric shaft mounting plate allows height adjustment.

Remove eccentric plate mounting screw. Using screwdriver or small rod, rotate the shaft clockwise to increase carriage height. Rotate the shaft counterclockwise to decrease carriage height. Reinstall mounting screw in nearest retainer hole. Adjust left and right side eccentric shafts (screw positions may vary from side to side). Adjust height such that horizontal arms do not contact top or bottom of tracks (align center).

Calibration Procedures

Platform Sense Calibration

1. Place 20 lbs. in the center of the platform.
2. Press UP button on the hand-held pendant to raise the platform a minimum of 3" above stow level.
3. Press and hold 50# CAL button on control board. While pressing the 50# CAL button, press and hold the STOW button on the hand-held pendant. The platform will lower to stow level, raise slightly, lower to stow level, and begin inward travel. Release the 50# CAL button when the platform begins moving inward. The platform sensing is now calibrated.
4. After calibration, the LCD screen should read "PF OCCUPIED" when 50 lbs., or more, are present on the platform. If 50 lbs. does not activate the "platform occupied" signal readout, recalibrate with less weight to lower the "occupied" setting or more weight to increase the "occupied" setting.

Ground Sense Calibration

1. Press hand-held pendant DOWN switch to lower platform fully to ground level.
2. While continuing to press the pendant DOWN switch, press and then release the control board O_BAR/GROUND LVL button.
3. Release the pendant DOWN switch. Ground Level sensing is now calibrated.
4. After calibration, the outer barrier should not unfold (down) until the platform is fully on the ground.

Outer Barrier Occupied Calibration

1. Press hand-held pendant DOWN switch to lower platform fully to ground level.
2. Once outer barrier is fully unfolded (ramp position), release the pendant DOWN switch.
3. Press and hold the control board O_BAR/GROUND LVL button. While holding O_BAR/GROUND LVL button, press hand-held pendant UP switch to raise the outer barrier. Be sure to release O_BAR/GROUND LVL button when outer barrier reaches approximately half full up (vertical) position.
4. After calibration, the LCD screen should read "OUT-BAR OCCUPIED" whenever there is weight present on the outer barrier.

LCD Diagnostic Codes

To change the LCD display from cycle count to diagnostic mode, press the “diag” button on the control board (see illustration at right). When finished, press button again to return to cycle count mode. When all of the harnesses are correctly connected to the control board, the values shown in the chart below will display when the corresponding action is taken. “1” will appear to the right of the switch or sensor name on the LCD module when activated as shown. If any other value appears on the LCD screen during the specific diagnostic procedure, verify that the correct harness is properly connected to both the control board and the associated lift harness. Repeat the harness diagnostic procedure. If an incorrect value is still present after checking the harness and connections, contact The Braun Corporation Product Support Department.

All basic functions (UP, DOWN, STOW and DOOR) should show a value of 1 when activated via a controlled input (Hand-held Pendant, Magnetic, Remote Entry or 3rd Station Controls).



Hand-held Pendant

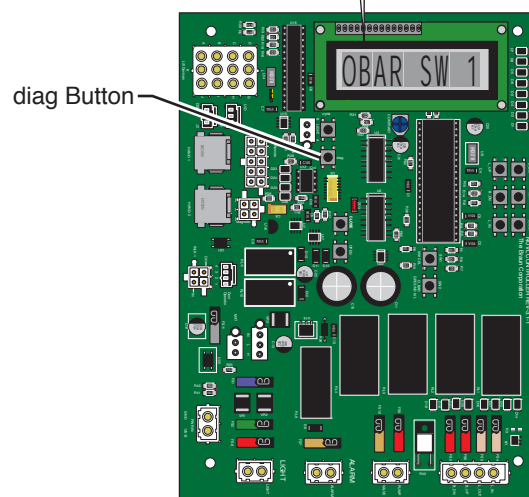
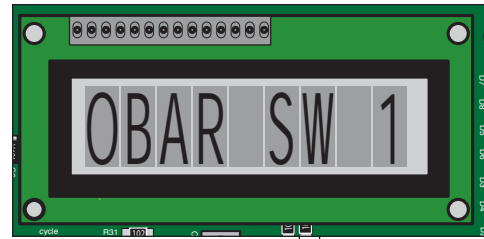

NUVL Control Board

LCD Display	Stowed	Moving Out Of Cassette	Moving Up From Stow	At Floor Level	Moving Down From Stow	Ground Level	Ground Level OB Out
STLV SW			1	1			
LOUT SW	1						
FOUT SW			1	1	1	1	1
FLV SW				1			
OBAR SW	1	1	1	1	1	1	
MAT SW	= 1 when mat is activated.						
DO SW	= 1 when door is full open or pin 3 and pin 4 are jumpered.						
*IBAR SW	= 1 when inboard locator is activated						

*(NUVL855C only)

Floor Level and Inboard Locator Adjustments

Achieving proper floor level positioning of the platform and inboard locator requires a combination of Floor Level switch adjustment and inboard locator cam adjustment. Both are factory set, but floor level positioning must be inspected during installation procedures (will vary per vehicle application).

Floor Level Requirements:
When the lift is positioned at floor level (raised fully), the bottom of the platform must be above floor level (threshold mat)

and the inboard locator must rest solidly on vehicle floor with 7° maximum angle (relative to the platform).

Ensure the lift is positioned and secured as specified on the Quick Reference Installation Sheet supplied with the lift.

Adjust the Floor Level switch first (detailed below). If the 7° requirement above is not met, adjust the inboard locator cam as detailed in Cam Adjustment (adjust cam only if necessary).

CAUTION

Do not adjust inboard locator linkage rod. Linkage rod adjustment may result in lift damage.

Do not adjust the inboard locator linkage rod (see Photo H on page 10). The linkage rod should be adjusted to increase usable platform length only (following all other procedures).

Floor Level Switch Adjustment

The Floor Level switch stops upward travel of the platform during the Up function (activated by the torque tube-mounted Floor Level cam).

1. Position the bottom of the lift platform 1" above floor level (threshold mat) using the manual hand pump. See Figure A.
2. Loosen the clamp securing the torque tube-mounted Floor Level cam. See Photo A. Rotate the cam until the Floor Level switch is activated (cam depresses switch). Tighten the clamp securing the cam.

Hydraulic pressure may affect platform height slightly. Fine tuning adjustment (tweaking) of the Floor Level switch (cam) may be required.

3. Using the control pendant, check floor level position by lowering the platform to stow level and then pressing the UP button until the platform raises fully (stops).

If the inboard locator rests solidly on vehicle floor with 7° maximum angle (relative to the platform), move to page 10 and check the usable platform length as outlined.

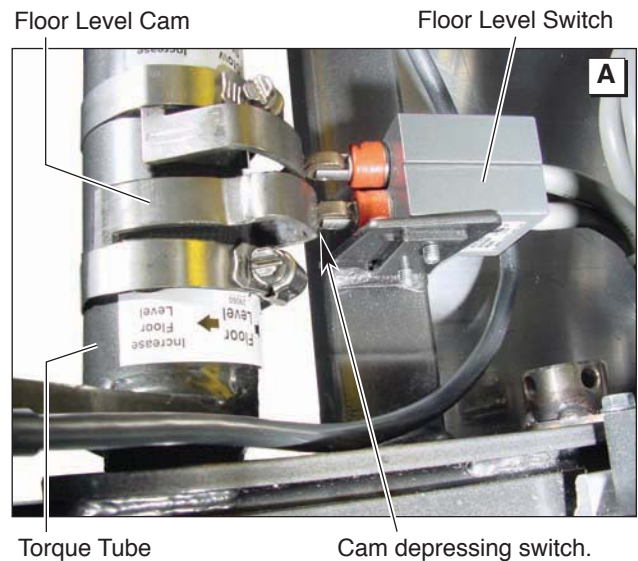
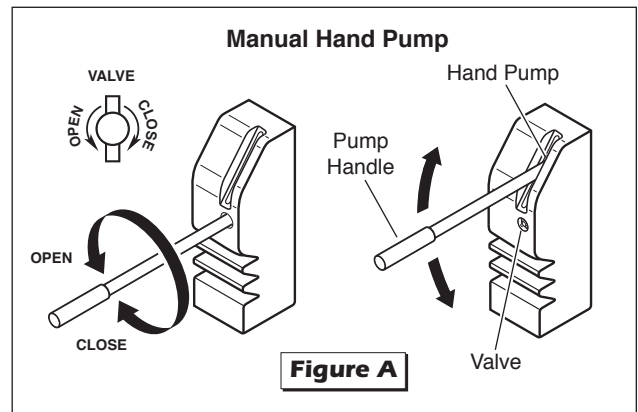

Floor Level and Inboard Locator Adjustments

Floor Level Switch Adjustment

4. If the inboard locator does not rest solidly on vehicle floor or the angle is more than 7°, open the hand pump valve (turn counterclockwise) to lower platform slightly (1/4" maximum). Close valve. See Figure A.
5. Reset the floor level switch cam to this new position. See Photo A. Loosen the clamp securing the torque tube-mounted Floor Level cam. Rotate the torque tube-mounted Floor Level cam until the Floor Level switch is activated (cam depresses switch). Tighten the clamp securing the cam.
6. Using the control pendant, check floor level position by lowering the platform to stow level and then pressing the UP button until the platform raises fully (stops).

Floor Level Requirements: When the lift is positioned at floor level (raised fully), the bottom of the platform must be above floor level (threshold mat) and the inboard locator must rest solidly on vehicle floor with 7° maximum angle (relative to the platform).

If the inboard locator rests solidly on vehicle floor with 7° maximum angle (relative to the platform), move to page 10 and check the usable platform length as outlined.

If the inboard locator does not rest on the vehicle floor (hovers above floor) - adjust the 9-hole cam as detailed in the following section.

Inboard Locator Cam Adjustment

Adjust the Floor Level switch first (detailed in previous section). If the above Floor Level Requirements are not met - adjust the inboard locator cam as detailed in the following procedures.

1. Position the lift platform below stow level. See Photo B. Lowering the platform will allow access to the cam bolt securement nut. See Photo D.
2. Remove the 1/4" serrated flange nut securing the lifting arm cam bolt. See Photos C and D. Do not remove the bolt.
3. Using the control pendant, press the UP button until the platform raises fully (stops).
4. Remove the cam securement bolt (lift inboard locator to relieve pressure on bolt). Allow the inboard locator to rest on the floor.

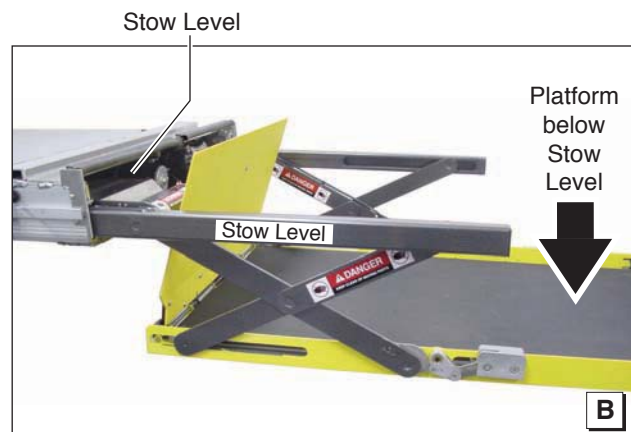

Floor Level and Inboard Locator Adjustments

Inboard Locator Cam Adjustment

5. Rotate the cam so the cam follower bearing engages the cam notch (saddle). See Photos E and F.
6. Reinstall the cam securement bolt in one of the three lifting arm holes that aligns best with one of the nine cam holes. See Photos E and F. Reposition the cam bolt flange lock nut. Tighten securely.
7. Use the control pendant to lower lift platform to stow level and then raise platform fully to floor level (stops). Measure angle of inboard locator and verify the slope is a maximum of 7° (relative to platform).

Note: Achieving proper floor level positioning of the platform and inboard locator requires a combination of Floor Level switch adjustment and inboard locator cam adjustment. Adjust as needed to meet Floor Level Requirements.

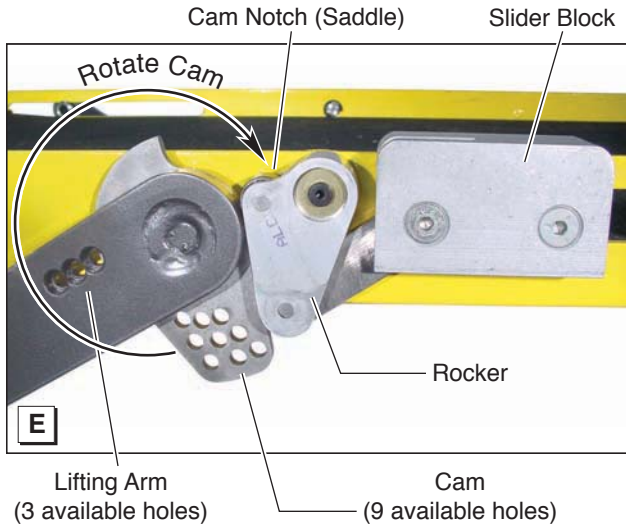
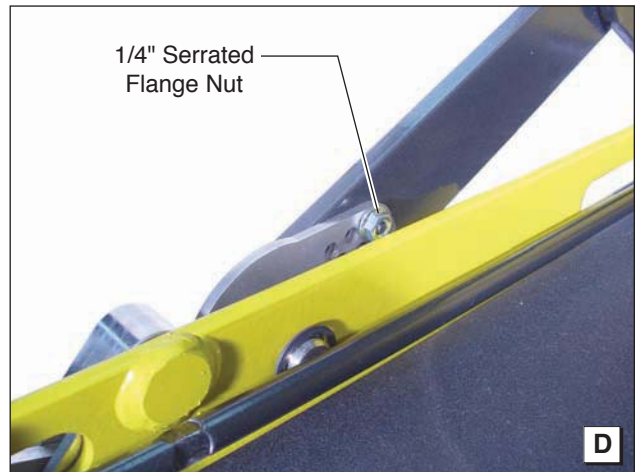
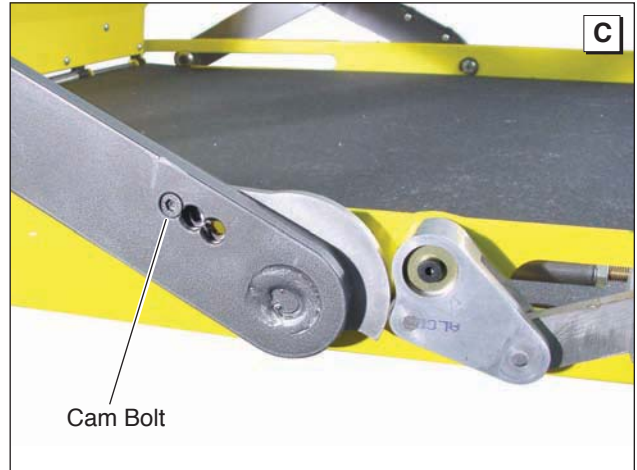

Floor Level and Inboard Locator Adjustments

Usable Platform Length

CAUTION

Improper inboard locator linkage rod adjustment may result in lift damage.

Do not adjust the inboard locator linkage rod unless extra usable platform length is needed. See Photo G.

If the angle of the inboard locator (when in the vertical position) restricts the usable platform length for the wheelchair passenger, adjustment of the linkage rod will change the angle.

Adjust the inboard locator as detailed in the previous procedures. Then, adjust the linkage rod as detailed (only if necessary). If the linkage rod is over adjusted (too long or too short), it will exceed the travel of the slider block resulting in damage to the cam follower bearing, the cam and/or other components.

Linkage rod adjustment affects angle of inboard locator (vertical position).



Linkage Rod Adjustment

1. Position the lift platform below stow level.
2. Loosen the jam nuts at each end of the linkage rod. Adjust rod length as needed. Minimize adjustment.
3. Carefully check the inboard locator angle and operation using the hand pump. Ensure the linkage rod has not been over adjusted resulting in pressure on components (damage will result).
4. Tighten the linkage rod jam nuts.

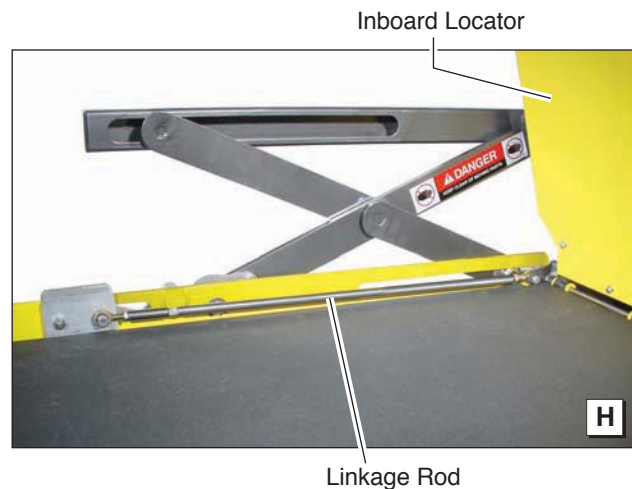

Lubrication Diagram

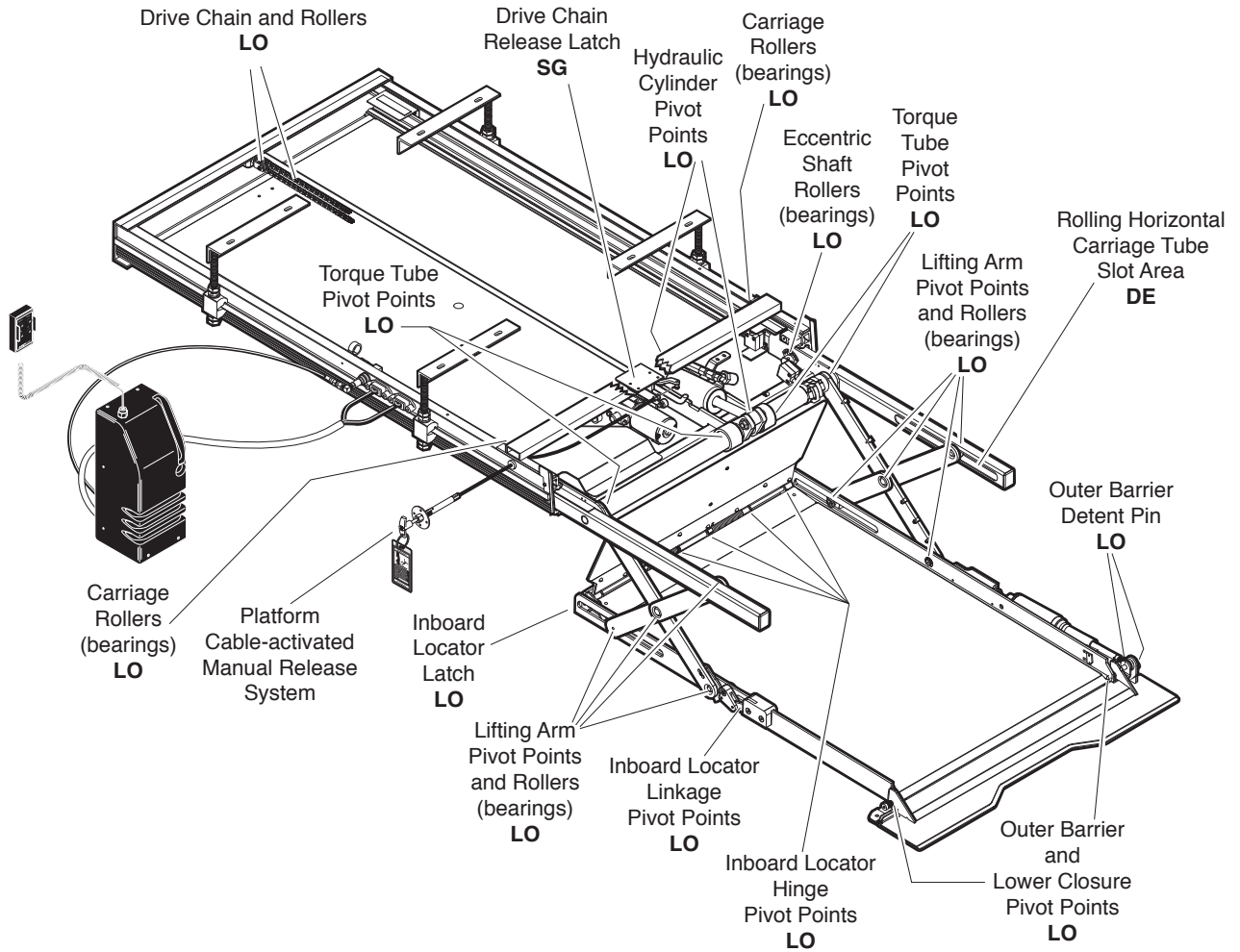

See the Maintenance/Lubrication Schedule for recommended applications per number of cycles.

Lubricant	Type	Specified (recommended) Lubricant	Available Amount	Braun Part No.
LO - Light Oil	Light Penetrating Oil (30 Weight or equivalent)	LPS2, General Purpose Penetrating Oil	16 oz. Aerosol Can	15807
DE - Door-Ease	Stainless Stick Style (tube)	Door-Ease Stick (tube)	1.68 oz.	15806
SG - Synthetic Grease	Synthetic Grease (Multipurpose)	Mobiltemp SHC32	12.5 oz. Tube	28598

Maintenance and Lubrication Schedule

Proper maintenance is necessary to ensure safe, trouble free operation. Inspecting the lift for any wear, damage or other abnormal conditions should be a part of a regular service program. Simple inspections can detect potential problems.

The maintenance and lubrication procedures specified in the following schedule must be performed by a Braun authorized service representative at the scheduled intervals according to the number of cycles. NUVL Series lifts are equipped with a cycle counter (digital display built into the electronic control board).

NUVL Series lifts are equipped with hardened pins and self-lubricating bushings to decrease wear, provide smooth operation and extend the service life of the lift.

When servicing the lift at the recommended intervals, inspection and lubrication procedures specified in the previous sections should be repeated. Clean components and the surrounding area before applying lubricants. LPS2 General Purpose Penetrating Oil is recommended where Light Oil is called out. Use of improper lubricants can attract dirt or other contaminants which could result in wear or damage to the components. Platform components exposed to contaminants when lowered to the ground may require extra attention. Lift components requiring grease are lubricated during assembly procedures. When replacing these components, be sure to apply grease during installation procedures. Specified lubricants are available from The Braun Corporation (part numbers on previous page).

All listed inspection, lubrication and maintenance procedures should be repeated at 750 cycle intervals following the scheduled 4500 cycle maintenance proce-

dures. These intervals are a general guideline for scheduling maintenance procedures and will vary according to lift use and conditions. Lifts exposed to severe conditions (weather, environment, contamination, heavy usage, etc.) may require inspection and maintenance procedures to be performed more often than specified.

Maintenance Indicator: The Lift Ready green LED mounted on top of the pump cover will change color to yellow after every 750 cycles. The yellow LED will not affect the functions of the lift, but is a reminder to complete necessary maintenance and lubrication.

Once the lift has been serviced, press the CYCLE button (located below LCD display on the control board) until the Lift Ready LED changes back to green. The CYCLE button also clears the lift cycle count (since last service) but not the lifetime cycle count.

Discontinue lift use immediately if maintenance and lubrication procedures are not properly performed, or if there is any sign of wear, damage or improper operation. Contact your sales representative or call The Braun Corporation. One of our national Product Support representatives will direct you to an authorized service technician who will inspect your lift.

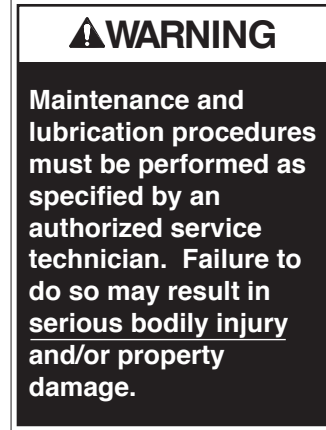

750 Cycles	Outer barrier and lower closure pivot points (2)	Apply Light Oil - See Lubrication Diagram
	Outer barrier detent pin pivot points (2)	Apply Light Oil - See Lubrication Diagram
	Inboard locator hinge pivot points and latch	Apply Light Oil - See Lubrication Diagram
	Inboard locator linkage pivot points	Apply Light Oil - See Lubrication Diagram
	Lifting arm pivot points and rollers (bearings)	Apply Light Oil - See Lubrication Diagram
	Inspect outer barrier and lower closure for proper operation	Correct or replace damaged parts.
	Inspect outer barrier seal and lower closure gasket	Resecure, replace or correct as needed
	Inspect outer barrier detent pin hairpin cotter	Ensure hairpin cotter is present and can be removed and inserted easily. Resecure, replace or correct as needed.
	Inspect lift for wear, damage or any abnormal condition	Correct as needed.

Maintenance and Lubrication Schedule

750 Cycles	Inspect lift for rattles	Correct as needed.
	Check drive chain tension.	Pull out and lock manual release cable. Adjust chain tension as needed. See Drive Chain Adjustment.
	Inspect inboard locator and linkage for: <ul style="list-style-type: none"> • Proper operation • Positive securement • Wear or damage • Proper adjustment 	Resecure, replace or correct as needed. See Floor Level and Inboard Locator Adjustment Instructions.
	Check carriage ride height in housing	Adjust as needed. See Carriage Ride Height Adjustment.
	Check stow height/lifting arm alignment	Lifting arms should be horizontal, aligned with each other and aligned with carriage. Adjust as needed. See Switch Adjustment (Stow Switch).
	Inspect wiring harnesses for securement, wear or other damage	Resecure, replace or correct as needed
	Check lower pan securement	Resecure, replace damaged parts or correct as needed.
1500 Cycles	Torque tube pivot bearings (4 places)	Apply Light Oil - See Lubrication Diagram
	Verify FMVSS 403/404 Certification Checklist	See Certification Checklist Diagnostic Procedures
	Carriage rollers (bearings)	Apply Light Oil - See Lubrication Diagram
	Eccentric shaft rollers (bearings)	Apply Light Oil - See Lubrication Diagram
	Rolling horizontal carriage arm slot area	Apply Door-Ease - See Lubrication Diagram. Apply to the surface area around both slots and wipe off excess.
	Hydraulic cylinder pivot points (4 per cylinder)	Apply Light Oil - See Lubrication Diagram
	Drive chain and chain rollers	Apply Light Oil - See Lubrication Diagram
	Drive chain release latch mechanism	Apply Synthetic Grease - See Lubrication Diagram
	Deploy lift, remove lower pan and blow out housing. Blow off platform also.	Use compressor and nozzle to remove all debris from housing. Clean lower pan slot and apply Antiseize to slot before reinstalling pan.
	Deploy lift, remove lower pan and clean housing tracks	Use clean cloth and solvent to clean tracks. Clean lower pan slot and apply Antiseize to slot before reinstalling pan.
Check drive chain tensioner, jam nuts and connecting link for securement and/or misalignment.	Correct or replace damaged parts and/or relubricate. See Drive Chain Adjustment.	
Inspect drive chain release latch mechanism for proper operation, positive securement, wear or other damage	Correct or replace damaged parts and/or relubricate.	
Inspect platform cable-activated manual release system (T-handle/cable assembly and carriage movement)	Ensure T-handle release and cable assembly operate properly. Ensure carriage can be manually extended and retracted freely.	

Maintenance and Lubrication Schedule

1500 Cycles	Inspect limit switches and cams for securement and proper adjustment	Resecure, replace or adjust as needed. See Adjustments and Calibration
	Inspect carriage, lifting arm and eccentric shaft rollers (bearings) for wear or damage, positive securement and proper operation	Correct, replace damaged parts and/or relubricate.
	Inspect external snap rings (e-clips): • Carriage roller bearings (4) • Lower lifting arm pins (4) • Eccentric shaft track roller bearing (1)	Resecure, replace or correct as needed.
	Inspect lower lifting arm pins for wear or damage, positive securement and proper adjustment	Resecure, replace damaged parts, lubricate or correct as needed.
	Inspect eccentric shaft pins, bearing mounting screw, washers and securement hardware for wear or damage, positive securement and proper operation	Resecure, replace damaged parts, lubricate or correct as needed. See Carriage Ride Height Adjustment.
	Inspect torque tube cams for securement, wear or damage	Resecure, replace or correct as needed.
	Inspect housing cam brackets for securement, wear or damage	Resecure, replace or correct as needed.
	Inspect cylinder(s), hoses, fittings and hydraulic connections for wear, damage or leaks	Tighten, repair or replace if needed.
Inspect power cable	Resecure, repair or replace if needed.	

4500 Cycles	Hydraulic Fluid (Pump) - Check level. Note: Fluid should be changed if there is visible contamination. Inspect the hydraulic system (cylinder, hoses, fittings, seals, etc.) for leaks if fluid level is low.	Use Braun 87010R (5606 aviation fluid). Do not mix with Dextron III or other hydraulic fluids. Check fluid level with platform lowered fully. Fill to maximum fluid level indicated on reservoir (specified on decal). Do not overfill. If fluid level decal is not present - measure 7/8" from the bottom of fill tube to locate fluid level.
	Inspect lifting arm bushings and pivot pins for visible wear or damage	Replace if needed.
	Inspect outer barrier pivot pin mounting bolts (2) Mounting	Tighten or replace if needed Check to see that the lift is securely anchored to the vehicle and there are no loose bolts, broken welds, or stress fractures.
	Decals and Antiskid	Replace decals if worn, missing or illegible. Replace antiskid if worn or missing.

Consecutive 750 Cycle Intervals	Repeat all previously listed inspection, lubrication and maintenance procedures at 750 cycle intervals.
--	---

Troubleshooting Diagnosis Chart

⚠ WARNING

Troubleshooting and repair procedures must be performed as specified by authorized service personnel only. Failure to do so may result in serious bodily injury and/or property damage.

If a problem occurs with your lift, discontinue operation immediately! Do not attempt repairs yourself. Contact your dealer or call The Braun Corporation. One of our national service representatives will direct you to an authorized service repairman who will inspect your lift.

The cause of the problem can be determined by locating the lift function and related symptom in the Troubleshooting Diagnosis

Charts. The specific cause and remedy can then be determined by process of elimination. A Wiring Diagram, Electrical Schematic, Hydraulic Diagram and Hydraulic Schematic are provided to aid in troubleshooting.

A Repair Parts section with exploded views and corresponding parts lists is also provided. Correct the problem if possible. If the problem continues, contact The Braun Corporation.

FUNCTION	POSSIBLE CAUSE	REMEDY
1.00 NO OPERATION	1.11 Low Battery 1.12 Bad ground 1.13 Poor plug connections 1.14 Blown fuse 1.15 Circuit Sentry 1.16 Circuit Breaker 1.17 Defective Interlock	Check vehicle battery Check for good ground between vehicle chassis and 3/8" bolt on back of power pack. Check all plugs for proper contact. Check fuses on P.C. board. Manually reset Circuit Sentry (circuit breaker). Circuit breaker should automatically reset, otherwise replace. Check for voltage on gray wire with pink stripes in interlock plug connected to P.C. board.
2.00 PUMP RUNS BUT WILL NOT LIFT PLATFORM	2.11 Hydraulic valve open 2.12 Pump mounted horizontal 2.13 No oil (low)	Flush valve by operating manual override switches up and down at same time for 4 to 5 seconds several times. Power pack must be mounted vertically. Use Braun 87010R (5606 aviation fluid). Do not mix with Dextron III or other hydraulic fluids. Check fluid level with platform lowered fully. Fill to maximum fluid level indicated on reservoir (specified on decal). Do not overfill. If fluid level decal is not present - measure 7/8" from the bottom of fill tube to locate fluid level.
3.00 PUMP DOES NOT RUN WITH MAN- UAL OVER- RIDE OR HAND-HELD PENDANT	3.11 Up Solenoid 3.12 Bad power and ground	Check for power on black wire going from solenoid to motor. See 1.00

Troubleshooting Diagnosis Chart

FUNCTION	POSSIBLE CAUSE	REMEDY
4.00 LIFT WILL GO UP WITH OVERRIDE SWITCH BUT NOT WITH HAND-HELD PENDANT	4.11 Outer Barrier switch is not activated or defective. 4.12 Full Out switch is not activated or defective. 4.13 Hand-held pendant not working properly.	Check diagnostic LCD for Outer Barrier switch status. Barrier is down or barrier release pin partially out. See Outer Barrier Occupied Calibration on page 5. Replace switch as necessary. Check diagnostic LCD for Full Out switch status. Adjust or replace switch as necessary. Check for hand-held pendant illumination and continuity of the switches. Verify Door Open switch is functioning correctly.
5.00 LIFT WILL NOT GO DOWN WITH MANUAL OVERRIDE OR WITH HAND-HELD PENDANT OR GOES DOWN SLOWLY OR DRIFTS DOWN BY ITSELF	5.11 Hydraulic down valve bad 5.12 Dirty down valve (clogged)	Check for power on red wire from P.C. board to Down solenoid when pushing override button or hand-held pendant button. Replace if necessary. Flush valve by operating Up & Down manual override buttons at same time for 4 to 5 seconds several times.
6.00 LIFT WILL GO DOWN WITH OVERRIDE BUT NOT WITH HAND-HELD PENDANT	6.11 Full Out switch out of adjustment or defective. 6.12 Door Full Close switch out of adjustment or defective.	Check diagnostic LCD for Full Out switch status. Adjust or replace switch as necessary. Check switch for proper operation/adjustment. Adjust or replace switch as necessary.
7.00 LIFT WILL NOT GO OUT WITH HAND-HELD PENDANT	7.11 Missing shunt 7.12 Door Open switch out of adjustment or defective	Verify shunt (jumper) is located in the Door Operator 4-conductor jack (jumper pins 3 & 4) on the control board when door operators are not used. Check switch for proper operation/adjustment. Adjust or replace switch as necessary. See 1.00
8.00 LIFT WILL NOT GO OUT WITH OVERRIDE OR HAND-HELD PENDANT	8.11 Poor plug connections 8.12 Bad in/out motor 8.13 Bad power and ground	Check harness connections A1, A2, B1 and B2 Check power at motor. Replace motor if necessary. See 1.00
9.00 LIFT WILL NOT STOW WITH HAND-HELD PENDANT	9.11 Stow switch out of adjustment or defective. 9.12 Platform is occupied or out of calibration.	Check diagnostic LCD for Stow switch status. Adjust or replace as necessary. Remove weight from platform. See Platform Sense Calibration on page 5.

Troubleshooting Diagnosis Chart

FUNCTION	POSSIBLE CAUSE	REMEDY
10.00 BARRIER WILL NOT OPERATE UP OR DOWN WITH HAND-HELD PENDANT OR OVERRIDE SWITCHES	10.11 Poor plug connections	Check harness connectors A1 and A2, E1, N1, N2, E1, F1 and F2.
	10.12 Faulty barrier actuator motor or actuator out of adjustment	Check power at motor. Adjust or replace actuator if necessary.
	10.13 Bad power and ground	See 1.00
11.00 BARRIER OPERATES WITH OVERRIDE SWITCH BUT WILL NOT GO UP WITH HAND-HELD PENDANT	11.11 Faulty Outer Barrier switch	Check diagnostic LCD for Outer Barrier Switch status. Adjust or replace switch as necessary.
	11.12 Barrier occupied	Remove weight from barrier. See Outer Barrier Occupied Calibration on page 5.
12.00 BARRIER OPERATES WITH OVERRIDE SWITCH BUT WILL NOT GO DOWN WITH HAND-HELD PENDANT	12.11 Faulty Pressure Transducer	Check Pressure Transducer. Adjust or replace as necessary. See Ground Sense Calibration on page 5.
	12.12 Stow switch out of adjustment or defective	Check diagnostic LCD for Stow switch status. Adjust or replace as necessary.
	12.13 Full Out switch out of adjustment or defective	Check diagnostic LCD for Full Out switch status. Adjust or replace as needed.
13.00 SWITCHES DO NOT CHANGE STATE IN DIAGNOSTIC MODE	13.11 No power going to switches	Check power on connector A1, pins 1 and 2.
	13.12 Faulty wiring	Check continuity of wires from switches to connector A2.
	13.13 Faulty connections	Check for proper connections on each switch and on each connector on the harnesses. Replace contact if necessary. See diagram on following page.
14.00 DOORS DO NOT OPEN	14.11 Faulty wiring	Check for proper wiring to door openers.
15.00 DOORS DO NOT CLOSE	15.11 Lift Out switch out of adjustment or defective	Lift not stowed fully. Adjust lift out switch or replace.

Lift Accessories Wiring Schematic

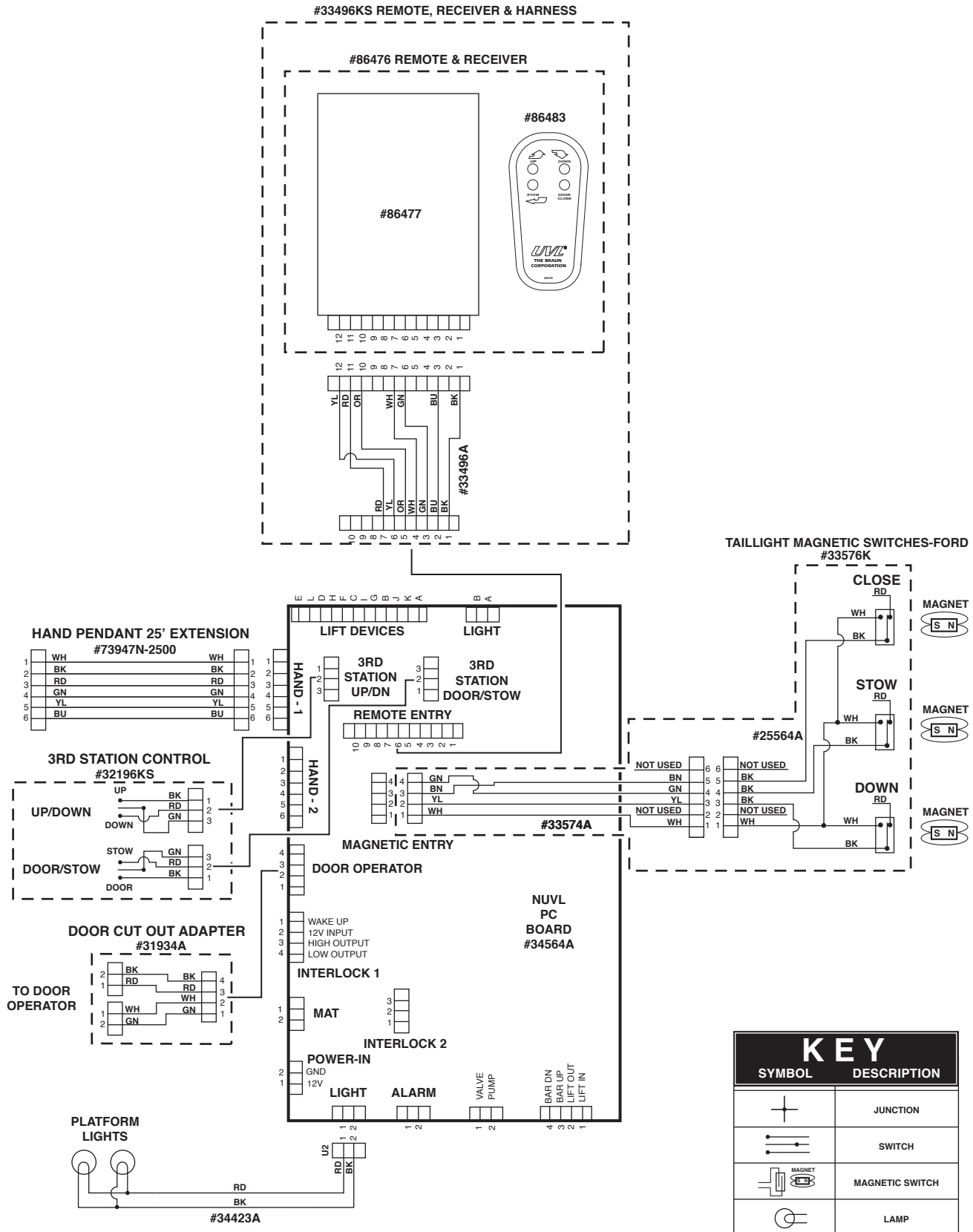

Lift Wiring Schematic

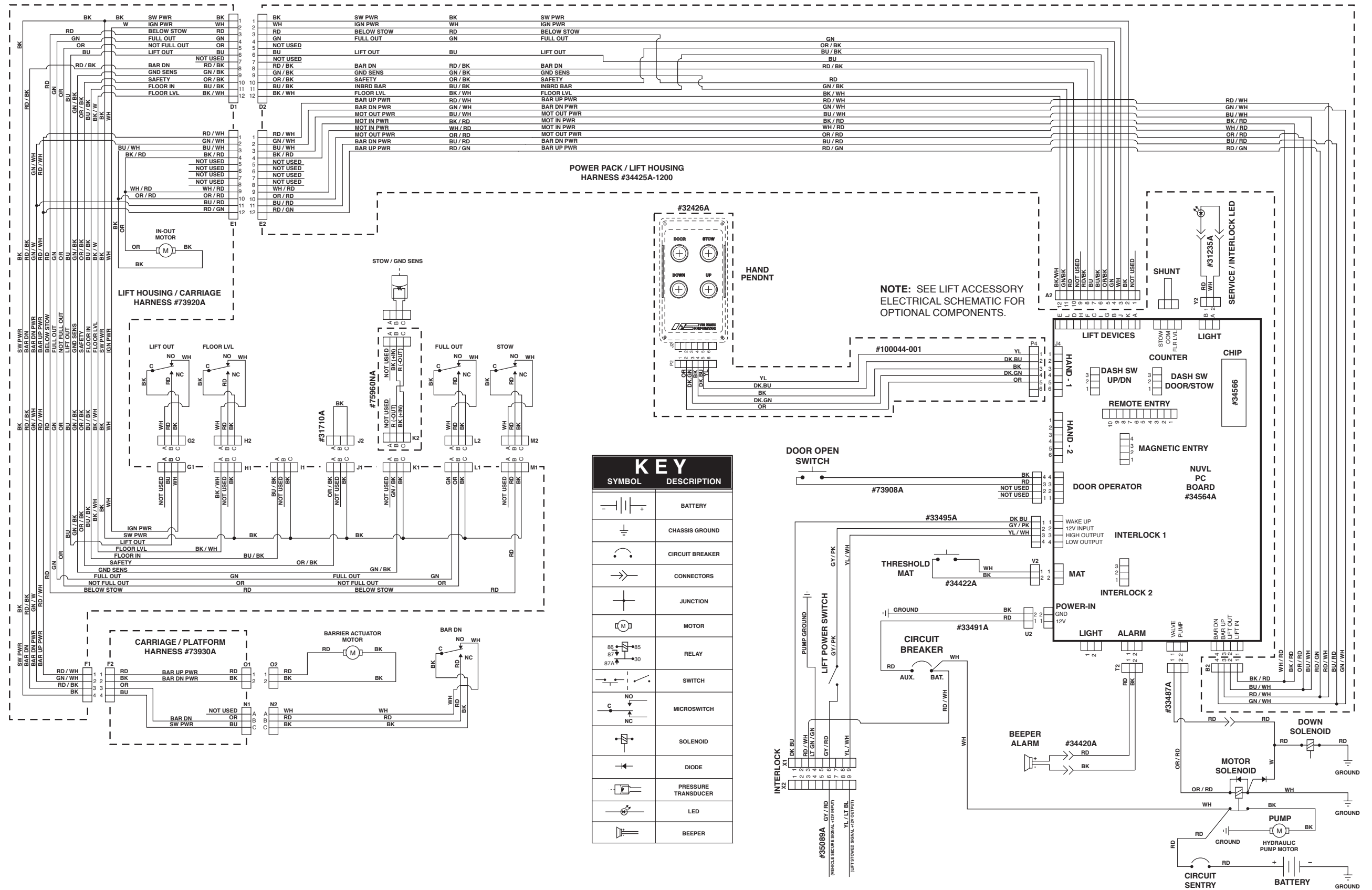

SYMBOL	DESCRIPTION
	BATTERY
	CHASSIS GROUND
	CIRCUIT BREAKER
	CONNECTORS
	JUNCTION
	MOTOR
	RELAY
	SWITCH
	MICROSWITCH
	SOLENOID
	DIODE
	PRESSURE TRANSDUCER
	LED
	BEEPER

Unfold for:
Lift Wiring Schematic

Hydraulic Parts List

Item	Qty.	Description	Part #
1	1	Pump Assembly (M259 with Reservoir/with Back-up pump)	87060
2	1	Motor, Pump - 12 Volt	14785-IS
3	1	Valve, "Down" (with Solenoid)	14901
4	1	Clamp, Reservoir - H-48	17069
5	1	Reservoir Replacement Kit (Includes Item #10)	88188K
6	1	O-Ring (only), Hand Pump Mounting	17351
7	1	Hand Pump (Backup) with O-Rings (Includes Item #6)	87065
8	3	Screw, 1/4-20 x 1 3/4", Allen Head	17351
9	1	Handle with Grip	17206A
10	1	Fitting, 3/8" Male NPT x 3/8" Barbed	87618
11	2	Clamp, Hose - 5/8" O.D. - Worm Drive	84325
12	1	Tubing, 3/8" x 5/8", Tygothane - Clear	82066R012
13	1	Plug, 3/8" Plastic Hose	81580
14	1	Fitting, 90°-1/8" Male Pipe x 1/8" Barbed	87563
15	1	Tube, 1/4" O.D. x 1/8" I.D. - Plastic	81557R014
16	1	Plug, 1/8" Plastic Tube	81583
17	1	Adapter, 1/4" Male NPT x 7/16-20 Male JIC 37°	10130
18	1	Hose Assembly, 1/4" x 154" - Female Swivel 7/16-20 JIC 37°	32785A-154
19	1	Fitting, 90° - 7/16-20 Male JIC 37° x 1/4" Male NPT	87569
20	1	Coupling, Hydraulic Quick Connect x 1/4" Female NPT	87614
21	1	Nipple, Hydraulic Quick Connect x 1/4" Female NPT	87615
22	1	Nut, 9/16-18, Hex Jam	83077
23	1	Fitting Assembly, Bulk Head	73777A
24	1	Hose Assembly, 1/8" x 60" - Female Swivel 7/16-20 JIC 37°	16004A-060
25	1	Fitting, 90° - 9/16" Male O-Ring x 7/16-20 Male JIC 37°	87622
26	1	Valve, Flow Control	87049
27	1	Adaptor, Hydraulic Internal	87560
28	1	Fitting, Tee - 1/4" Male NPT - 1/4" Female NPT - 1/4" Male NPT	26786
29	1	Fitting, 7/16" Female O-Ring x 1/4-18 NPT Male	29305
30	1	Switch, Pressure Transducer	30426
31	1	Fitting, 90° - 1/4" Female NPT Swivel x 7/16-20 O-Ring	26789
32	1	Cylinder, UVL Retracting	87055N
33	1	Clamp, Hose - Solenoid Mounting	29663
34	1	Solenoid, Up - Trombetta	31129
35	1	Diode Assembly, Up Solenoid	73906A

CONTACT REMOVAL

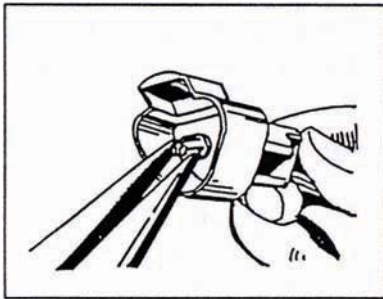

1. Remove orange wedge using needle nose pliers or a hook shaped wire to pull wedge straight out.

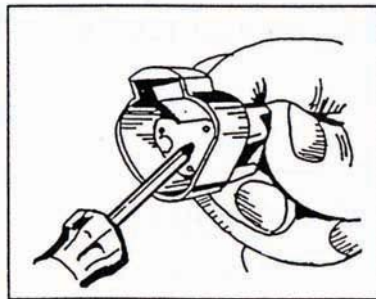

2. To remove the contacts, gently pull wire backwards, while at the same time releasing the locking finger by moving it away from the contact with a screwdriver.

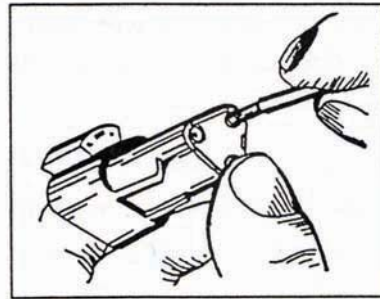

3. Hold the rear seal in place, as removing the contact will displace the seal

Hydraulic Diagram

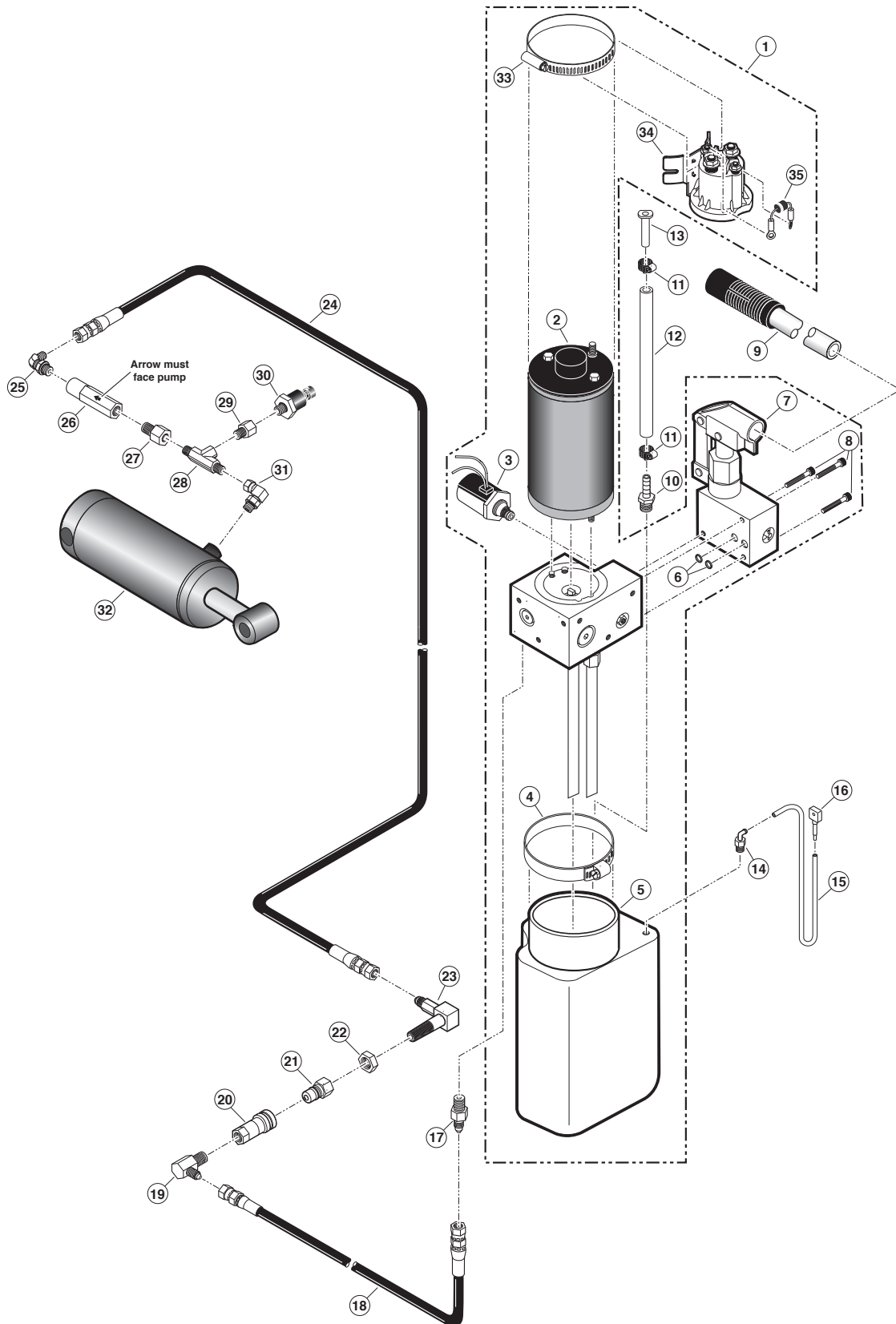

Pump Module Parts List

Item	Qty.	Description	Part #
1	1	Pump Assembly, M259	87060
2	1	Adapter, 1/4" Male NPT x 7/16-20 Male JIC 37°	10130
3	1	Hose Assembly, 1/4"- F. Swivel 7/16-20 JIC 37°	32785A-154
4	1	Fitting, 90° - 7/16-20 Male JIC 37° x 1/4" Male NPT	87569
5	1	Coupling, Hydraulic Quick Connect x 1/4" Female NPT	87614
6	1	Fitting, 3/8" Male NPT x 3/8" Barbed	87618
7	1	Tubing, 3/8" x 5/8", Tygothane - Clear	82066R012
8	2	Clamp, Hose - 5/8" O.D. - Worm Drive	84325
9	1	Plug, 3/8" Plastic Tubing	81580
10	1	Fitting, 90°-1/8" Male Pipe x 1/8" Barbed	87563
11	1	Tube, 1/4" O.D. x 1/8" I.D. - Plastic	81557R014
12	1	Plug, 1/8" Plastic Tube	81583
13	1	Clamp, Hose - Solenoid Mounting	29663
14	1	Solenoid, Up - Trombetta	31129
15	1	Diode Assembly, Up Solenoid	73906A
16	1	Diode Assembly, Down Valve Solenoid	73907A
17	1	Terminal, 14/16 Gage Male Spade - 1/4" Fully Insulated	78036
18	2	Jumper Assembly, 12 Gage x 4"	73943A
19	1	Eyelet, 5/16" Insulated - Red	86267
20	1	Weldment, Bracket - PC Board Mounting	73824W
21	1	Circuit Breaker, 20 Amp - Self Reset	16453
22	1	Clip, Cable - 7/16" Plastic	15777
23	2	Screw, 10-32 x 3/8", Pan Head Philips, Thread Cutting	82755
24	4	Standoff, .25" PCB - Nylon	86739
25	4	Screw, #6 x 3/8". Self Tap, Flat Head	82764
26	5	Bumper, 1/2" Dia. x 1/4" Tall - Rubber	82064
27	1	Electrical Board Assembly w/Program Chip	34564A
28	1	Beeper, Constant - High Output	33251
29	1	Edge Liner, 1/8" x 6", Q-Trim	13910R006
30	1	Edge Liner, 1/8" x 4", Q-Trim	13910R004
31	1	Washer, .328" x .562" x .042"	83583
32	3	Screw, 5/16-18 x 1/2", Serrated Washer Head, Hex	82881
33	1	Plate, Power Pack Mounting	73822N
34	1	Bracket, Power Pack Mounting ✕	73825
35	7	Screw, 1/4-20 x 3/8", Pan Head Phillips ✕	82769
36	2	Washer, Lock - 1/4" External Tooth ✕	83588
37	1	Lamp, Bicolored LED Panel	30728
38	1	Fitting, Strain Relief - Liquid Tight	30753
39	1	Switch, Toggle	12185
40	1	Harness, Interlock	33495A
41	1	Plate, Interlock Plug / Cover Reinforcement	31345
42	1	Harness, Lift Interlock Connection	35089A
43	1	Harness, Service / Power Indicator	31235A
44	2	Rivet, Pop, 1/8" Dia. x .188/.250"	84249
45	1	Cover, UVL Power Pack w/Decals ✕	73820RNA-02
46	1	Hand Pendant Assembly, NHTSA UVUL ✕	32426A
47	1	Harness, Alarm	34420A
48	1	Ground Cable - Black	68874
49	1	Screw, 5/16-18 x 3/4", Serrated Washer Head, Hex	32464
50	1	Harness, Power	33491A
51	1	Harness, Pump / Valve	33487A
52	1	Handle, Back-up Pump ✕	17206A
53	2	Clamp, Spring - Pump Handle ✕	12350
54	2	Screw, #10-32 x 3/8", Flat Head - Phillips ✕	82767
55	2	Washer, #10 Flat ✕	11541
56	2	Nut, #10-32, Hex ✕	11542

✕ Indicates items available for replacement part purposes only. These items are not included with replacement pump modules.

Pump Module Diagram

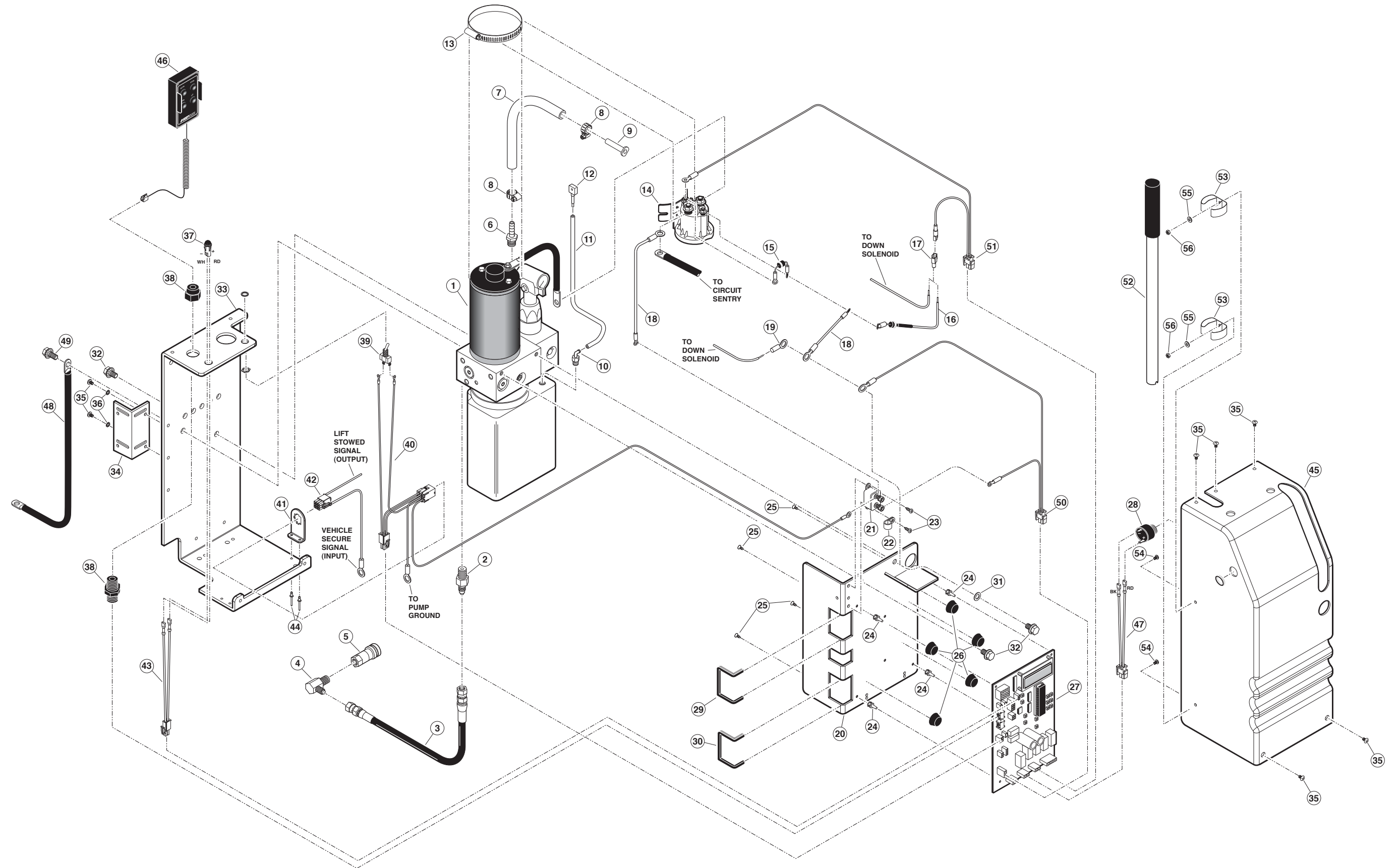

Unfold for:
Pump Module
Exploded View

Complete Lift Exploded View

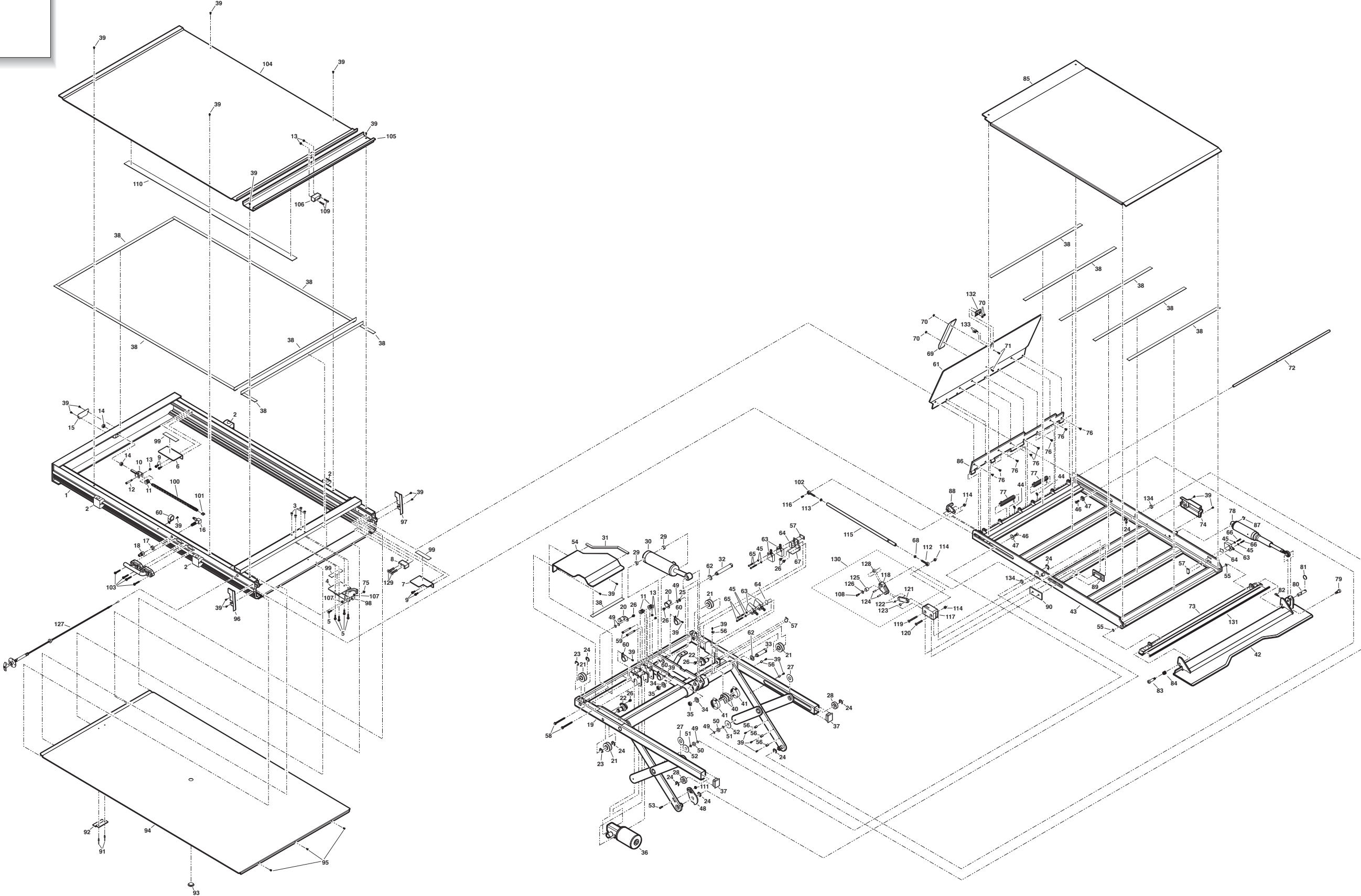

Repair Parts List

Item	Qty.	Description	Part No.	Item	Qty.	Description	Part No.
1	1	Housing Weldment	73101NW	69	1	Skid, Rear Barrier	74402-15
2	4	Clamp, Lift Mounting	73733	70	2	Nut, 10-32 Serrated Flange ZP	83080
3	4	Nut, 1/4" NC Rivet	83020	71	2	Screw, 10-32 x 1/2" PH PN ZP	82744
4	1	Chain Release Assembly	73760A	72	1	Shaft, Rear Barrier Hinge	74413
5	5	Screw, 1/4-20 x 1, Serrated Hex	82760	73	1	Closure, Weldment, NUVL603C	73330NW
6	1	Bracket, In-Out Cam, Inboard	73774	74	1	Cover, Platform Wiring Harness	73738
7	1	Bracket, In-Out Cam, Outboard	73775	75	1	Nut, 1/4-20, Serrated Hex	83064
8	1	Block, Carriage Stop	75781N	76	8	Screw, 1/4-20 x 3/8 FL SOC CAP HD	23471
9	4	Screw, 1/4-20 x 3/4", Washer Head	24750	77	2	Spring, Torsion	85101EVO
10	1	Chain Tensioner Weldment	76750W	78	1	Barrier Actuator Assembly	74340-3S
11	3	Roller, Chain Idler, Nylon	73706	79	1	Screw, 1/2" x 1/2" SHLD SKT HD x 3/8-16	25929
12	1	Screw, 5/16 x 1/4" Shoulder, Soc. Hd., 1/4-20	82751	80	1	Pin, Barrier Clevis Release	73741-2
13	5	Nut, 1/4-20 Nylock, Full Thread	83070	81	1	Ring, Clevis Pin 5/16"	11390
14	2	Nut, 1/2-20, Hex, Jam	83022	82	1	Clip, Hairpin, 5/16" DIA Shaft	84382
15	1	Cover, Chain Tensioner	71754	83	1	Screw, 5/16 x 1 1/4" Shoulder Socket Head	82751
16	1	Fitting Assembly, Bulk Head	73777A	84	1	Spring, Lower Closure Torsion	73335
17	1	Nut, 9/16-18 Hex Jam ZP	83077	85	1	Plate, Platform Floor	74306-1
18	1	Nipple, Hydraulic Quick Disconnect	87615	86	1	Hinge Weldment Rear Barrier	74420NW
19	1	Carriage Weldment	73201NW	87	1	Ring, Retaining 5/8"	84189
20	2	Shaft Bearing Weldment	73230W	88	1	Catch, Weldment, Rear Barrier	74415W
21	4	Bearing, Track Roller 20 x 52mm	84305	89	1	Block, Nylon Slider Inside	74410
22	2	Shaft, Eccentric Bearing Weldment	73230W	90	1	Block, Nylon Slider Outside	74409
23	2	E-Clip 3/4" Bowed .580 Groove	84377	91	2	Rivet, Pop, SD64BS-3/16"- .13/.25, Auto Black	11513
24	8	E-Clip 3/4" .580 Groove DIA	84376	92	1	Bracket, Lower Housing Cover	73108
25	1	Washer, .2811" ID x .625" OD x .055"	83511	93	1	Plug, Poly Finish, 1" Hole, Black	81576
26	6	Screw, 1/4-20 x 3/8", Serrated Hex	82761	94	1	Cover, Lower	73732-2
27	2	Washer, Front Scissor Arm	73748	95	3	Screw, 10-32 x 3/8", Flat HD PH ZP	82767
28	2	Bearing, Scissor/Carriage Tube	84320	96	1	Lip, LH Side Seal	73745N
29	2	Bushing, 3/4" ID x 3/8", Peer12FB06	900-0455	97	1	Lip, RH Side Shield	73744N
30	1	Cylinder	87055N	98	1	Cam, 7/8" UVL Follower	84052
31	1	U-Channel, Edge Trim	82000R012	99	1	Tape, 1" Wide S-Face Foam	82015R
32	1	Pin, Cylinder Rod Mounting Long	75700N	100	1	Chain, Nickel Plated Roller, #35	84314R120
33	1	Pin, Cylinder Rod Mounting	75701N	101	1	Connector Link, #35 Chain	84317
34	2	Washer, UVL Cylinder Rod Pin	31137	102	1	Rod End, 5/16-24 Male	84384
35	2	Nut, 9/16-18 x 5/16" Thick Stainless Jam	31176	103	4	Screw, 1/4-20 x 1 1/2" Washer HD TYPF	24751
36	1	Motor, Electric, In/Out - w/Sprocket and Dowel	73780AS	104	1	Cover, Upper	73730N
37	2	Plug, 1 1/2" x 2" x 11 Gauge Tube	81582	105	1	Lid, Upper Edge Seal	73746N
38	1	Tape, 1/16" x 3/4" Double Face	82033R333	106	1	Bearing, Rear Barrier Slide	31127
39	27	Screw, 10-32 x 3/8" Pan Head, Thread Cut	82755	107	2	Nut, 3/8-24 Jam, ZP	83074
40	2	Cam, Torque Shaft Actuator	73712	108	1	Bolt, 1/4-20 x 1/2" Socket Low HD	82335
41	2	Clamp, 1 5/16" x 2 1/4" x 1/2", Worm Drive	26400	109	2	Bolt, 1/4-20 x 1" Socket HD, SS	24752
42	1	Barrier, NUVL603C, Weldment	73321NWY	110	1	Tape, 1/8 x 2" Foam Adhesive	82054R048
43	1	Platform Weldment	73301NWY	111	1	Nut, 1/4-20 Serrated Flange ZP	83064
44	2	E-Clip, 3/8" Shaft	84383	112	2	Rod End, 5/16-24 Left Hand Male	84385
45	6	Washer, #10 Internal Tooth	11540	113	2	Nut, 5/16-24 Hex, Jam ZP	83075
46	2	Screw, 5/16-24 x 7/8", Flat Hd. Soc. Cap	82763	114	3	Nut, 5/16-24 Nylock Plated	83079
47	2	Retainer, Scissor Bearing	73737	115	1	Tie Rod, Rear Barrier	74407
48	1	Cam, Rear Barrier	74403	116	1	Bolt, 5/16-24 x 1" SKT BTN PLTD	82348
49	4	Washer, .328" x 2" x .562" x .042"	83583	117	1	Block, Rear Barrier Slider	74408
50	2	Bearing, Scissor Platform	84321	118	1	Rocker, Rear Barrier	74404
51	2	Washer, Rear Scissor Bearing	73755	119	1	Bolt, 5/16-24 x 2 1/4" SKT Flat	82346
52	2	Washer, Rear Scissor Arm	73749	120	1	Bolt, 5/16-24 x 2" SKT Flat Plated	82347
53	1	Bolt, 1/4-20 x 5/8" Socket Head	82333	121	1	Link, Rear Barrier	74406
54	1	Shield, Carriage Wire Harness	73742	122	1	Bearing, Split 1/4" I.D. x 1/4" Long	84395
55	2	Washer, .390 x .625 x .073, SS	83585	123	1	Bushing, Link, Rear Barrier	74411
56	6	Clamp, 1/4" ID Nylon Loop, Black	84396	124	2	Pin, .25" x .81" Dowel	74412
57	3	Plate, Switch Bracket, Tap	68280-1	125	1	Bearing, 5/8 I.D. x 5/8" LG Split	84394
58	2	Screw, 1/4-20 x 2 3/4", Serrated Hex	82759	126	1	Washer, .281 x .75 x .06 Brass	83592
59	2	Screw, 5/16 x 2 SHLD SKT HD 1/4-20 SS	82758	127	1	Manual Release Cable Assy. Kit	73770-600
60	4	Clamp, Insulate 1"	20535	128	1	Cam Follower, 1/4 I.D. x 3/4" O.D. x .5"	84392
61	1	Plate, Rear Barrier	73401N-15GMG	129	2	Screw, 3/8-16 x 1 3/4" SS, FHCS	30385
62	2	Washer, .758 ID x 1.245 OD x .06	25141	130	1	Link/Rocker Assembly - IB	74431A
63	5	Limit Switch Assembly	73950AS	131	1	Sponge Strip, 1/2" x 1/4"	82063R036
64	3	Tape, Limit Switch Mounting Pad	73747	132	1	Skid, Rear Barrier	75414C
65	4	Screw, 10-32 x 1 1/2", Socket Cap	82717	133	2	Screw, #10-32 x 1/2" FHDHXS	17192P
66	2	Screw, 10-32 x 7/8", Socket Cap	82778	134	2	Bearing, .75 I.D. x .25 LG Split - 12DU04	84282
67	1	Bracket, Switch In/Out Mounting	73719				
68	1	Nut, 5/16-24 LH Hex Jam ZP	83076				

Lift Housing Detail Exploded View

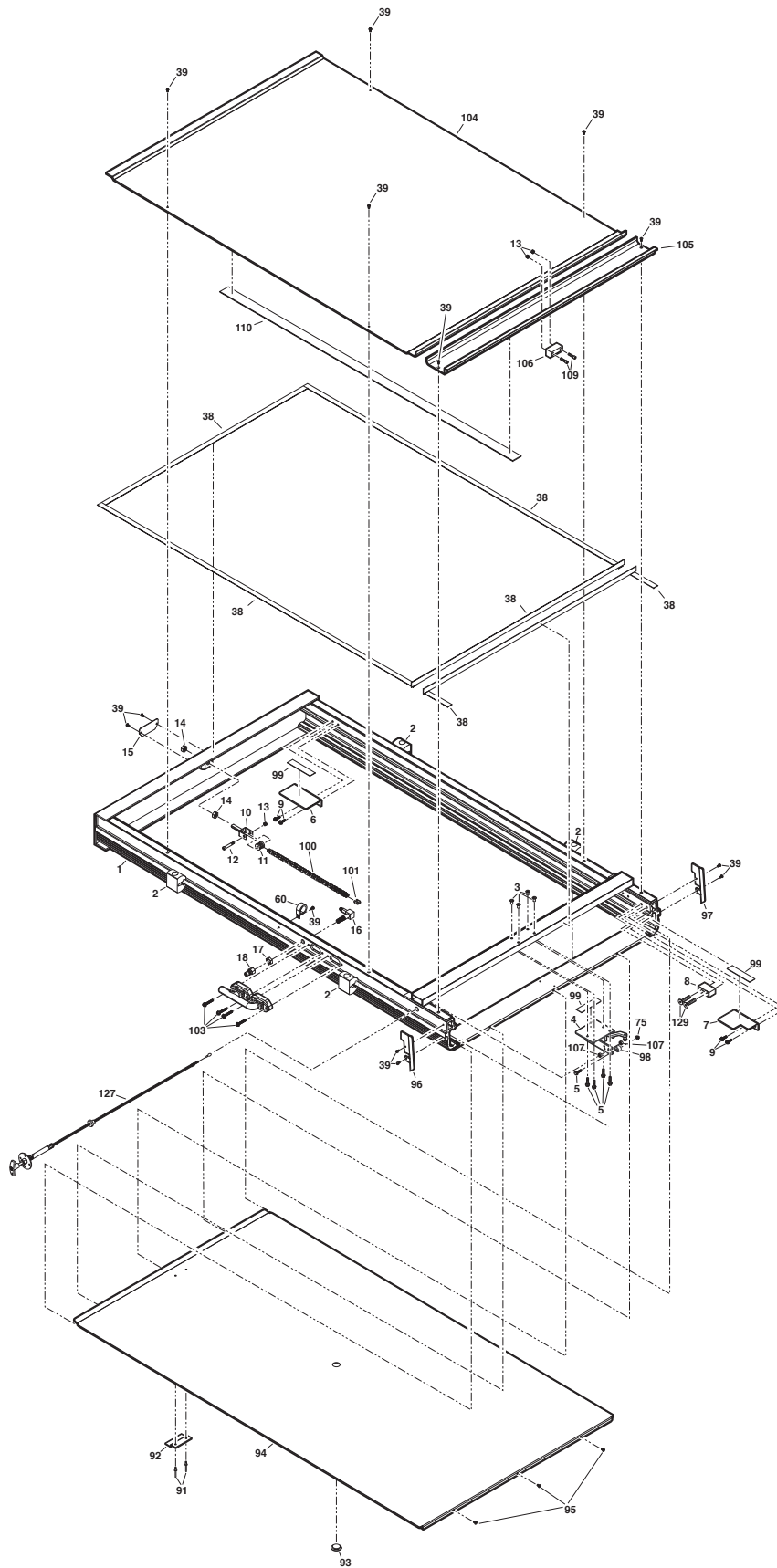

Lift Carriage Detail Exploded View

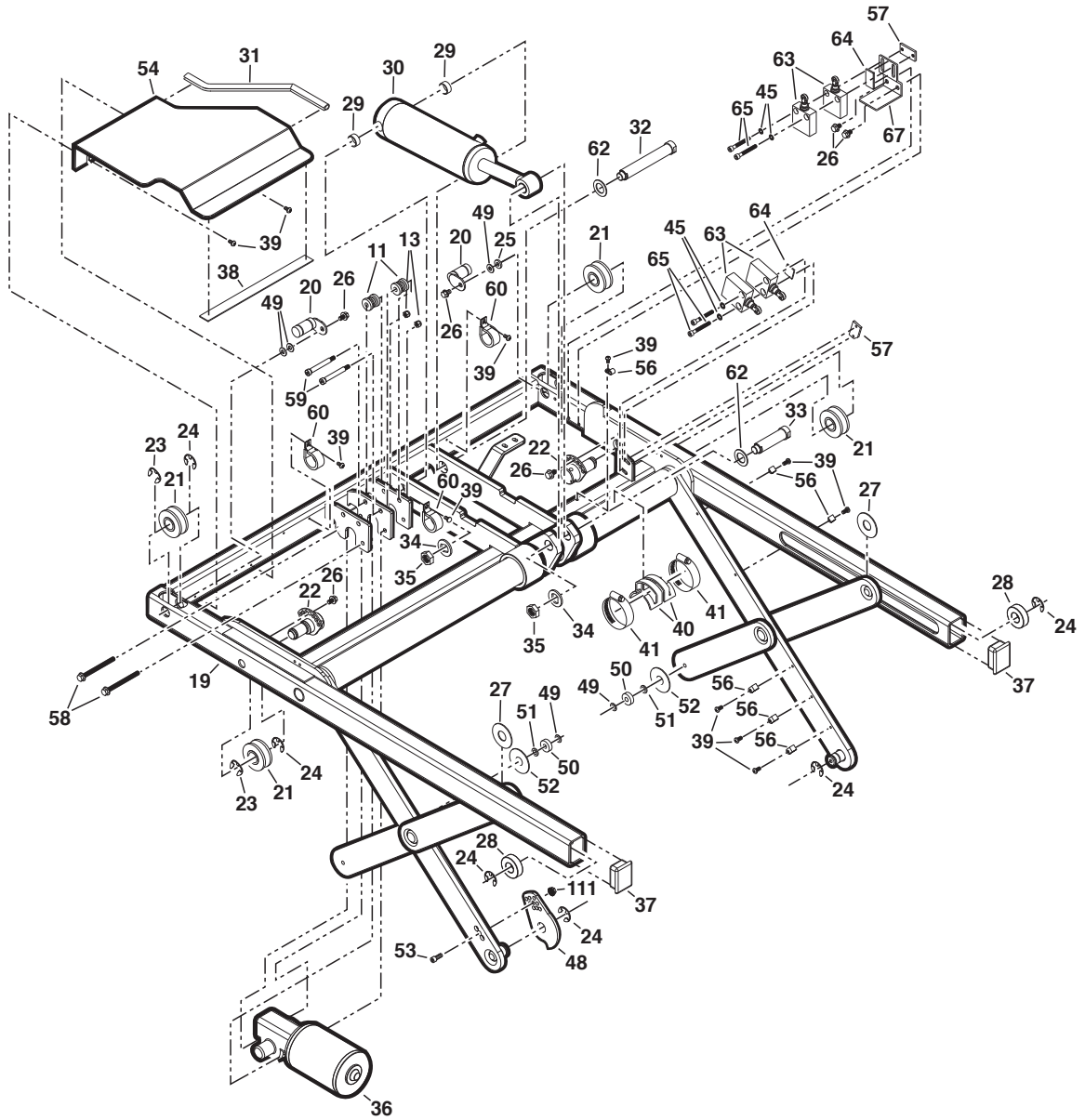

Lift Platform Detail Exploded View

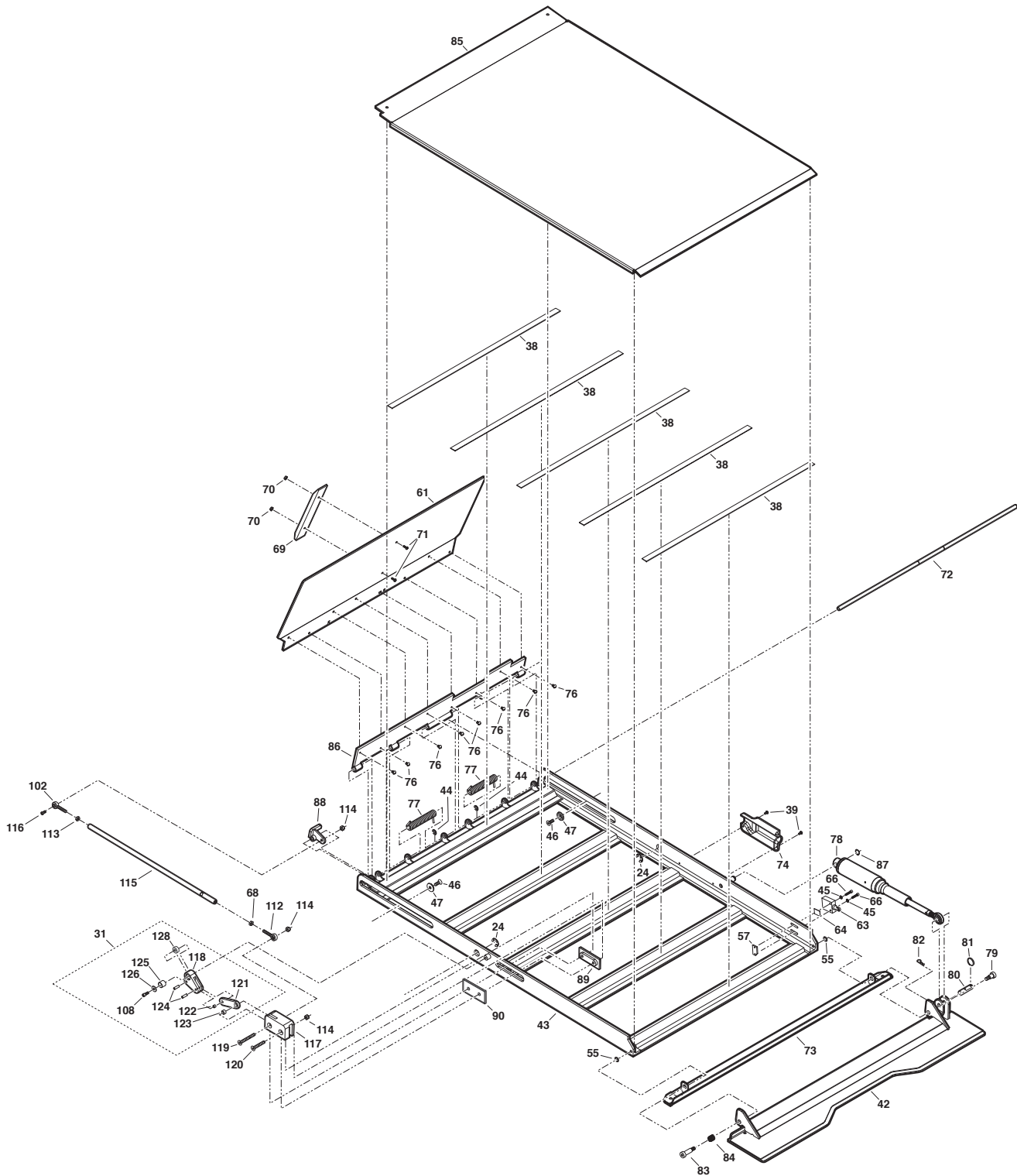

Braun® Limited Warranty

WARRANTY COVERAGE AND WARRANTY COVERAGE TIME PERIODS

The Braun Corporation (“Braun”) warranty covers certain parts of this wheelchair lift for three (3) years or 10,000 cycles and the cost of labor to repair or replace those parts for one (1) year or 3,000 cycles. This limited warranty covers substantial defects in materials and workmanship of the lift, provided that the lift is operated and maintained properly and in conformity with the owner’s manual. The warranty period begins on the date that the product is delivered to the first retail purchaser by an independent, authorized dealer of Braun, or, if the dealer places the product into any type of service prior to retail sale, on the date the dealer first places the product in such service. This limited warranty applies only to the first purchaser. It may not be transferred.

WHAT BRAUN WILL DO TO CORRECT PROBLEMS

In the event that a substantial defect in material or workmanship, attributable to Braun, is found to exist during the first year of warranty coverage, it will be repaired or replaced, at Braun’s option, without charge for parts or labor to the owner, in accordance with the terms, conditions and limitations of this limited warranty. If the substantial defect in material or workmanship, attributable to Braun, is found to exist during the second or third year of warranty coverage, it will be repaired or replaced, at Braun’s option, without charge to the owner for parts, only, in accordance with the terms, conditions and limitations of this limited warranty. The cost of labor for any repair or replacement in the second and third year of warranty coverage is the sole responsibility of the owner. This warranty does not cover labor costs in the second or third year of coverage.

Braun’s obligation to repair or replace defective materials or workmanship is the sole obligation of Braun under this limited warranty. Braun reserves the right to use new or remanufactured parts of similar quality to complete any work, and to make parts and design changes from time to time without notice to anyone. Braun reserves the right to make changes in the design or material of its products without incurring any obligation to incorporate such changes in any previously manufactured product. Braun makes no warranty as to the future performance of this product, and this limited warranty is not intended to extend to the future performance of the product. In addition, the owner’s obligation to notify Braun, or one of its authorized, independent dealers, of a claimed defect does not modify any obligation placed on the owner to contact Braun directly when attempting to pursue remedies under state or federal law.

LIMITATIONS, EXCLUSIONS AND DISCLAIMER OF IMPLIED WARRANTIES

ANY IMPLIED WARRANTY THAT IS FOUND TO ARISE BY WAY OF STATE OR FEDERAL LAW, INCLUDING ANY IMPLIED WARRANTY OF MERCHANTABILITY OR ANY IMPLIED WARRANTY OF FITNESS, IS LIMITED IN DURATION TO THE TERMS OF THIS LIMITED WARRANTY AND IS LIMITED IN SCOPE OF COVERAGE TO THE SCOPE OF COVERAGE OF THIS LIMITED WARRANTY.

Braun disclaims any express or implied warranty, including any implied warranty of fitness or merchantability, on items excluded from coverage as set forth in this limited warranty. Braun makes no warranty of any nature beyond that contained in this limited warranty. No one has authority to enlarge, amend or modify this limited warranty, and Braun does not authorize anyone to create any other obligation for it regarding this product. Braun is not responsible for any representation, promise or warranty made by any independent dealer or other person beyond what is expressly stated in this limited warranty. Any selling or servicing dealer is not Braun’s agent, but an independent entity.

BRAUN SHALL NOT BE LIABLE FOR ANY INCIDENTAL OR CONSEQUENTIAL DAMAGES THAT MAY RESULT FROM BREACH OF THIS LIMITED WARRANTY OR ANY IMPLIED WARRANTY. THIS EXCLUSION OF CONSEQUENTIAL AND INCIDENTAL DAMAGES SHALL BE INDEPENDENT OF ANY FAILURE OF THE ESSENTIAL PURPOSE OF ANY WARRANTY, AND THIS EXCLUSION SHALL SURVIVE ANY DETERMINATION THAT THIS LIMITED WARRANTY OR ANY IMPLIED WARRANTY HAS FAILED OF ITS ESSENTIAL PURPOSE.

Braun® Limited Warranty

This warranty does not cover, and in no event shall Braun be liable for towing charges, travel, lodging, or any other expense incurred due to the loss of use of the product or other reason.

Some states do not allow limitations on how long an implied warranty lasts, or the exclusion or limitation of incidental or consequential damages, so the above limitations or exclusions may not apply to you.

HOW TO GET SERVICE

To obtain warranty service the owner must do all of the following:

1. Notify an authorized service center, of the claimed defect attributable to Braun, within the warranty coverage period designated above.
2. Provide the notification mentioned in (1), above, within ten (10) days of when the owner discovered, or should have discovered, the claimed defect.
3. Promptly schedule an appointment with and take the product to an authorized service center for service.
4. Pay any transportation costs and all expenses associated with obtaining warranty service.

Since Braun does not control the scheduling of service work at the independent dealerships you may encounter some delay in scheduling or completion of work. If you need assistance you may contact Braun, at 631 West 11th Street, Winamac, Indiana 46996; 1-800-THE-LIFT, (843-5438).

If two (2) or more service attempts have been made to correct any covered defect that you believe impairs the value, use or safety of the product, or if it has taken longer than thirty (30) days for repairs to be completed, you must, to the extent permitted by law, notify Braun directly, in writing, at the above address, of the unsuccessful repair(s) of the alleged defect(s) so that Braun can become directly involved in providing service pursuant to the terms of this limited warranty.

WHAT IS NOT COVERED

This Limited Warranty does not cover any of the following: defects in materials, components or parts of the product not attributable to Braun, any material, component or part of the product that is warranted by another entity (Note: the written warranty provided by the manufacturer of the material, component or part is the direct responsibility of that manufacturer); items that are added or changed after the product leaves Braun's possession; additional items installed at any dealership, or other place of business, or by any other party, other than Braun; normal wear, tear, usage, maintenance, service, periodic adjustments, the effects of condensation or moisture from condensation; mold or any damage caused by mold; imperfections that do not affect the product for its intended purpose; items that are working as designed but that you are unhappy with; problems related to misuse, mishandling, neglect or abuse, including failure to maintain the product in accordance with the owner's manual, or other routine maintenance such as inspections, lubricating, adjustments, tightening of screws, sealing, wheel alignments or rotating tires; damage due to accident or collision, including any acts of weather or damage or corrosion due to the environment; theft, vandalism, fire, or other intervening acts not attributable to Braun; damage resulting from tire wear or tire failure; defacing, scratches, dents or chips on any interior or exterior surface of the product, including those caused by rocks or other road hazards, damage caused by off road use, overloading or alteration of the product, or any of its components or parts;

Defects and/or damage to interior and exterior surfaces and other appearance items may occur at the factory or when the product is in transit. These items are usually detected and corrected at the factory or by a dealer prior to delivery to the purchaser. You must inspect the product for this type of damage when you take delivery. If you find any such defect or damage you must notify the selling dealer, or Braun, at the time of delivery to have these items covered by this limited warranty and to have work performed on the items at no cost to you as provided by this limited warranty.

Braun® Limited Warranty

EVENTS DISCHARGING BRAUN FROM OBLIGATION UNDER WARRANTY

The following shall completely discharge Braun from any express or implied warranty obligation to repair or replace anything and void this warranty: misuse, neglect, collision, accidents, failure to provide routine maintenance (See Owner's Manual), unauthorized alteration, off road use, Acts of Nature, damage from weather or the environment, theft, vandalism, tampering, fire, explosions, overloading the product and odometer tampering.

LEGAL REMEDIES

Any action to enforce any portion of this limited warranty, or any implied warranty, must be commenced within six (6) months after expiration of the warranty coverage period designated above or the action will be barred because of the passage of time. Any performance of repairs shall not suspend this limitation period from expiring. Any performance of repairs after the warranty coverage period has expired, or performance of repairs regarding any thing excluded from coverage under this limited warranty shall be considered "good will" repairs, and they will not alter the terms of this limited warranty, or extend the warranty coverage period or the filing limitation period in this paragraph. In addition, since it is reasonable to expect that the product will need some service during the warranty period, this warranty does not extend to future performance. It only sets forth what Braun will do and does not guarantee anything about the product for any time period. Nothing in this warranty, or any action of Braun, or any agent of Braun, shall be interpreted as an extension of any warranty period or the filing limitation period in this paragraph. Some states do not allow a reduction in the statute of limitations, so this reduction may not apply to you.

WARRANTY REGISTRATION and MISCELLANEOUS

Your warranty registration records should be completed and delivered to the appropriate companies, including the Braun Delivery Checklist & Warranty form. That form must be returned to Braun within twenty (20) days of purchase. The Braun warranty will not be registered unless this warranty registration is completed and received by Braun. Failure to file this warranty registration with Braun will not affect your rights under this limited warranty as long as you can present proof of purchase, but it can cause delays in obtaining the benefits of this limited warranty, and it changes the start date of the warranty to the date of final assembly of the product by Braun.

Braun agrees to repair or replace any of its factory installed parts found to have substantial defects within the appropriate warranty period designated above, provided that the repair is authorized by Braun and carried out by an authorized service center (a Braun labor schedule determines the cost allowance for repairs). Braun will not honor any warranty claim for repairs or replacement of parts unless the claim is submitted with the appropriate paperwork, and the work is completed by an independent, factory authorized service center. The appropriate paperwork can be obtained by written or phone contact with Braun at the contact information in this warranty.

Braun reserves the right to designate where any warranty work can be performed. Braun also reserves the right to examine any defective workmanship or part prior to giving any authorization for warranty work. Braun's return authorization procedure must be adhered to in order to process any warranty claims.

THIS WARRANTY GIVES YOU SPECIFIC LEGAL RIGHTS. YOU MAY ALSO HAVE OTHER RIGHTS THAT VARY FROM STATE TO STATE.

NOTES

This page intentionally left blank.

"Providing Access to the World"®



**Over 300 Braun
Dealers Worldwide**

 **THE BRAUN
CORPORATION**
"Providing Access to the World"®



International Corporate Hdqrs: P.O. Box 310 Winamac, IN 46996 USA
1-800-THE LIFT® (574) 946-6153 FAX: (574) 946-4670

Service Manual for:

NUVL603C

Private Use Wheelchair Lifts

Under-Vehicle Lift®

Series 02

Patent #5,305,486



"Providing Access to the World"®

International Corporate Hdqrs: P.O. Box 310 Winamac, IN 46996 USA
1-800-THE LIFT® (574) 946-6153 FAX: (574) 946-4670



Braun UVL Series™

35033 Rev. A
March 2010

All illustrations, descriptions and specifications in this manual are based on the latest product information available at the time of publication. The Braun Corporation reserves the right to make changes at any time without notice.