

BRAUN **200**TM **Transit Ramp**

with Weight Sensor & Sensitivity Edge

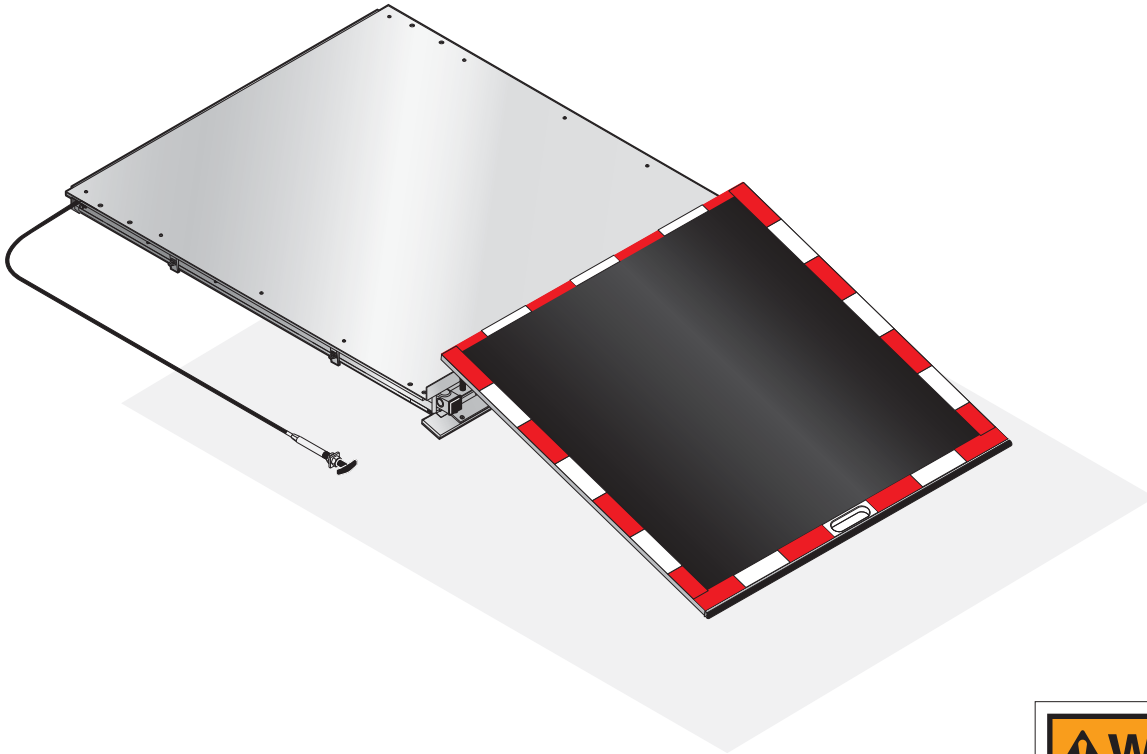

THE BRAUN
CORPORATION[®]
"Providing Access to the World"[®]

International Corporate Hdqrs: P.O. Box 310 Winamac, IN 46996 USA
1-800-THE LIFT (574) 946-6153 FAX: (574) 946-4670



! WARNING

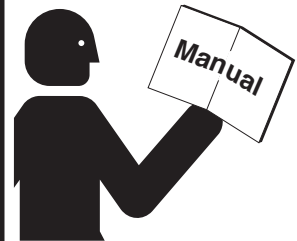

Read manual before operating, installing or servicing ramp. Failure to do so may result in serious bodily injury and/or property damage.

34952 Rev B

July 2010

Patent 7,264,433

Owner's/Service Manual

RA200 Transit Ramp

Congratulations

We at The Braun Corporation wish to express our fullest appreciation on your new purchase.

With you in mind, our skilled craftsmen have designed and assembled the finest ramp available.

This manual includes operating instructions, installation instructions, servicing instructions and instructions for troubleshooting, if needed.

Braun ramps are built for dependability and will provide years of service and mobility independence, as long as the ramp is installed and maintained as specified, and the ramp is operated by an instructed person.

Sincerely,

THE BRAUN CORPORATION

A handwritten signature in black ink that reads "Ralph W. Braun". The signature is written in a cursive style with a prominent initial "R" and a long, sweeping underline.

Ralph W. Braun
Chief Executive Officer

Terminology

ER1301WS Terminology Illustration	2
Introduction.....	3
Ramp Components.....	3
Ramp Actions and Functions.....	3

Safety Precautions

Safety Symbols	4
Safety Precautions	4, 5

Installation Instructions

Installation Procedures	6
User Inputs/Outputs.....	7

Operation

Pre-Operation Notes

Operation Procedure Review	8
Preventative Maintenance	8
Cold Climate Recommendations	8

Ramp Operating Instructions

Before Operating Ramp	8
Customer Interlock	8
Operator Input Switches	8
Two-Way Toggle Operation	8
Halt Conditions	8
Obstructions	8, 9

Operation Functionality

One-Touch Operation	9
Ramp Enable	9
"Close All Doors" Input	9
Opening Door	9
Obstruction Sensing	9
Pressure Mat Detection	9
Ramp Alarm	9

Manual Operating Instructions

Mechanical Method

Cable-Activated Manual Release System	10
Manual Release System Security Sensor	10
Self-Locking Release Pin	10
To Manually Extend or Retract Ramp	10
Reengage Carriage Assembly Drive Chains ..	10, 11
To Manually Raise or Lower Ramp	11

Electrical Method

Control Box Manual Input (Override Switches)	11
---	----

Maintenance, Lubrication and Adjustments

Exterior Maintenance and Lubrication	12, 13
Exterior Adjustments	13-15
Interior Maintenance and Lubrication	16
Interior Adjustments	17-20

Inspection List

Exterior Inspection	21, 22
Interior Inspection	23

Troubleshooting

Troubleshooting Guide	24, 25
-----------------------------	--------

Repair Parts

Parts List - ER1301WS Overall Exploded View ...	26
Exploded View - ER1301WS Overall	27A, 28A
Exploded View - ER1301WS Carriage & Ramp Assembly	27B, 28B
Parts List - ER1301WS Carriage & Ramp Assembly	29
Parts List - ER1301WS Frame Assembly	30
Exploded View - ER1301WS Frame Assembly	31A, 32A
Exploded View - ER1301WS Ramp Subassemblies	31B, 32B
Parts List - ER1301WS Ramp Subassemblies	33

Schematics

Electrical Schematic - ER1301WS Ramp Caradap Controller	35
Electrical Schematic - ER1301WS Ramp Wiring Harness (Caradap Controller)	36

Terminology

ER1301WS Terminology Illustration

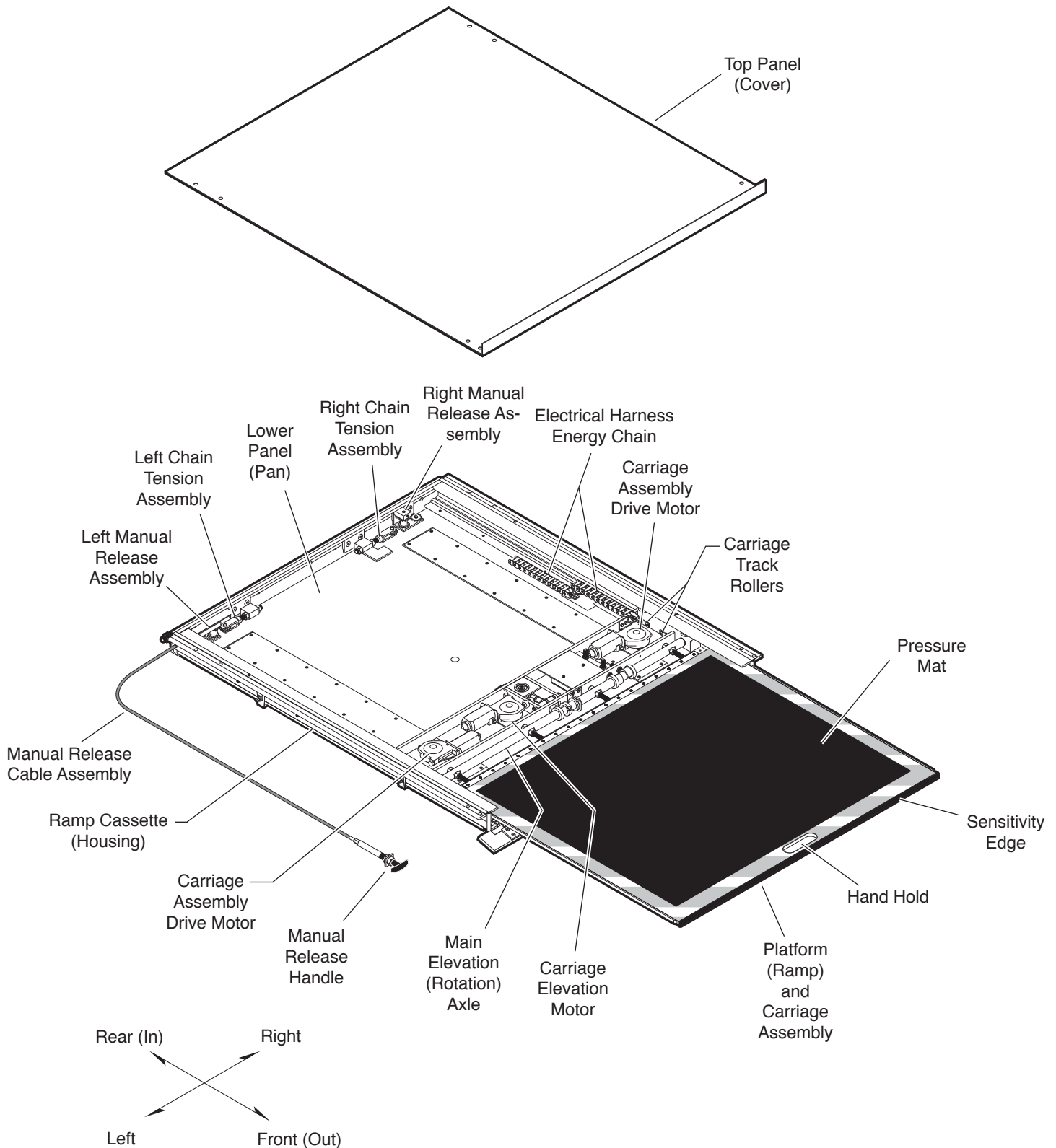

As viewed from outside the vehicle

Introduction

The RA200 provides fully automatic operation of all ramp functions. Basic ramp operation procedures are identical for all RA200 models. The operating instructions contained in this manual address the operator input switches and the corresponding ramp functions. Instructions are provided for manual operation of the ramp in the event of power or equipment failure.

Terminology: Become familiar with the terminology that will be used throughout this manual. Become familiar with the identification of RA200 components and their functions. Contact your ramp sales representative or call The Braun Corporation at 1-800-THE LIFT if any of this information is not fully understood.

Direction: The terms “left”, “right”, “front” and “rear” will be used throughout this manual to indicate direction (as viewed from the outside of the vehicle looking directly at the ramp’s front cover). Refer to the Ramp Terminology Illustrations for clarification to direction terms.

Ramp Components

Refer to the Ramp Terminology Illustrations and descriptions on pages 2 and 3.

Control Box (Electronic Controller): The remote mounted control box provides the logic to manage the inputs in order to produce the desired outputs in terms of ramp function and performance. In general terms of abilities and features, the control box is commonly referred to as the “controller.”

Ramp Cassette (Housing):

The ramp cassette is the metal structure (casing) mounted under the vehicle which contains and protects the platform and carriage assemblies. The cassette contains all ramp components except the control box when the ramp is in the stowed position.

Carriage Assembly: The carriage assembly consists of the steel weldment that contains the four track rollers, the main rotation axle and the electric drive motors. The carriage assembly powers the platform assembly in and out of the housing during operation.

Platform Assembly: The platform assembly consists of the flat aluminum laminate upon which the wheelchair travels, the sensitivity edge, the supporting hinge, the associated skid pads, and pressure mat.

Cable-activated Manual Release System: A cable-activated manual release system disengages or “unlocks” the carriage assembly drive chains to allow the platform and carriage assemblies to be manually moved out (extended) or moved in (retracted), should it be necessary. Complete details and manual operating procedures are provided on page 10 and 11.

Ramp Actions and Functions

Extend: Extend is the action of the platform and carriage assembly moving out of the ramp cassette (housing).

Retract: Retract is the action of the platform and carriage assembly moving into the ramp cassette.

Deploy: Deploy is the action of the platform and carriage assembly extending and raising (elevating) to floor level when the DEPLOY (OUT) switch is activated.

Stow: Stow is the action of the platform and carriage assembly lowering to stow level, and fully retracting when the STOW (IN) switch is activated.

Stow Level: Stow level is the height at which the platform and carriage assembly extends and retracts.

Floor Level: Floor level is the height that the platform assembly raises (elevates) to in order for the wheelchair to enter or exit the vehicle.

Obstruction Sensing: An obstruction sensing feature is standard with the RA200. The controller monitors the instantaneous current of all the electric motors, and calculates a ‘real time’ running average of the current. It then compares programmed peak (maximum vs. instantaneous) and delta (instantaneous minus running average) limits to determine if an obstruction has been encountered. The programmed limits for the different models of the RA200 are selected while configuring the controller during ramp installation procedures (see Installation Instructions for detailed information).

Obstruction Force: The obstruction force is the maximum allowable force (pounds or Newtons) the ramp exerts on a object during a specific movement. There is a different force for each of the four movements (extend, retract, raise, lower). This force is a direct result of the obstruction sensing current limits, usually specified by the customer.

Note: Further details regarding ramp control switches and the corresponding ramp functions are provided in the Ramp Operating Instructions below and on page 8 and 9.

Safety Precautions

Safety Symbols

SAFETY FIRST! Know That....

A All information contained in this manual and supplements (if included), is provided for your safety. Familiarity with proper operation instructions as well as proper maintenance procedures are necessary to ensure safe, troublefree operation. Safety precautions are provided to identify potentially hazardous situations and provide instruction on how to avoid them.

B



C

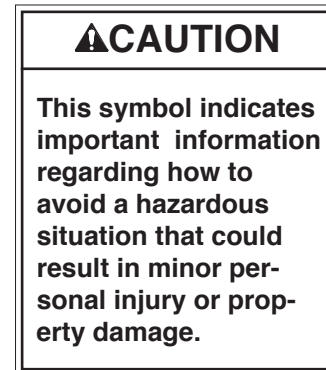

D **Note:** Additional information provided to help clarify or detail a specific subject.

These symbols will appear throughout this manual. **Recognize the seriousness of this information.**

Safety Precautions

⚠️ WARNING Read this manual and supplement(s) before performing installation, operation or service procedures.

RA200 Operation Safety Precautions

⚠️ WARNING Read manual and supplement(s) before operating ramp. Read and become familiar with all safety precautions, pre-operation notes, operating instructions and manual operating instructions before operating the ramp.

⚠️ WARNING Inspect ramp before operation. Do not operate ramp if you suspect lift damage, wear or any abnormal condition.

⚠️ WARNING Load and unload clear of vehicular traffic.

⚠️ WARNING Load and unload on level surface only.

⚠️ WARNING Engage vehicle parking brake before operating ramp.

⚠️ WARNING Provide adequate clearance outside the vehicle to accommodate the ramp.

⚠️ WARNING Keep operator and bystanders clear of area in which the ramp operates.

⚠️ WARNING Do not overload or abuse. The load rating capacity is 300 kilograms (660 pounds).

⚠️ WARNING Ramp must be positioned at floor level when loading or unloading in and out of vehicle.

⚠️ WARNING Do not activate control switches when anyone is near the area in which ramp operates.

⚠️ WARNING Do not operate or board the ramp if you or your ramp attendant are intoxicated.

⚠️ WARNING Wheelchair passengers must position and secure (buckle, engage, fasten, etc.) the wheelchair-equipped occupant seat belt before loading onto the ramp.

RA200 Operation Safety Precautions (continued)

- ⚠WARNING** Be aware of the ramp slope (angle).
- ⚠WARNING** Do not raise front wheelchair wheels (pull wheelie) when loading (boarding) the platform.
- ⚠WARNING** The wheelchair must be positioned in the center of the ramp when loading and unloading.
- ⚠WARNING** After manually releasing ramp, stow ramp and push manual release T-handle in fully and move ramp in and out to engage ramp lock before driving vehicle. Failure to lock ramp may result in unintended ramp deployment.
- ⚠WARNING** Keep owner's manual in ramp-mounted vehicle at all times.
- ⚠WARNING** Never modify (alter) a Braun Corporation ramp.
- ⚠WARNING** Do not use accessory devices not authorized by The Braun Corporation.
- ⚠WARNING** Do not remove any guards or covers.
- ⚠WARNING** If the information contained in this manual is not fully understood, contact The Braun Corporation immediately.
- ⚠WARNING** Failure to follow these safety precautions may result in serious bodily injury and/or property damage.

Installation and Service Safety Precautions

- ⚠WARNING** Read this manual, supplement(s) before performing installation, operation or service procedures.
- ⚠WARNING** Check for obstructions such as gas lines, wires, exhaust, etc. before drilling or cutting during installation procedures.
- ⚠WARNING** Route all cables clear of exhaust system, other hot areas, moving parts, wet areas, etc.
- ⚠WARNING** Risk of electrical shock or fire! Use extra care when making electrical connections. Connect and secure as outlined in Installation Instructions and Wiring Schematics.
- ⚠WARNING** Maintenance and lubrication procedures must be performed as specified in this manual by authorized (certified) service personnel.
- ⚠WARNING** Disconnect the power cable at the battery prior to servicing.
- ⚠WARNING** Replacement parts must be Braun authorized replacements.
- ⚠WARNING** Never install screws or fasteners (other than factory equipped).
- ⚠WARNING** Failure to follow these safety precautions may result in serious bodily injury and/or property damage.

Installation Instructions

ER1301WS Installation:

Braun ER1301WS electronic controller 100465-002 is exclusive for Weight Sensor ramps. Install Weight Sensor RA200 models as outlined in this section.

Parts List (ER1319):

Item	Qty.	Description	Part No.
1	1	Control Box - ER1301WS	100465-002

Installation Procedures:

1. Mount ramp assembly using the eight holes shown in Photo C. Mounting hardware **must** be minimum 7/16" or 12mm diameter. Position the ramp, with top cover lip flush with vehicle door threshold. Level the unit front-to-back and side-to-side. Mounting procedures other than those specified here **must** be pre-approved by a Braun representative.
2. Route free end of ER1317WSA harness through vehicle floor structure to desired mounting location of control box.

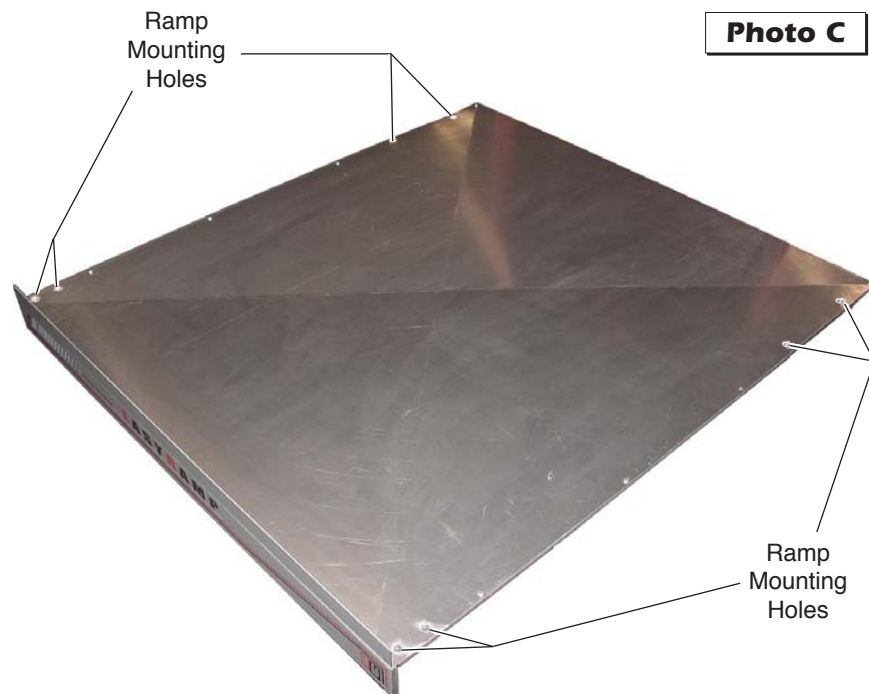

Photo D



Installation Instructions

User Inputs/Outputs

The weight sensor controller has five **required** user inputs and five optional user outputs. At least four user inputs are **required** to be connected in order for the ramp to function, whereas **none** of the user outputs must be connected (optional).

Below is a list of the user inputs and outputs, including the designated connector pin number, wire color, and description. **Please note the optional user outputs have maximum limitations as specified in the “Restrictions” column below.**

Controller to Vehicle Connections (929.505-3 Amp Connector)					
Function	Pin #	Wire Color	LED	Description	Restrictions
Input (Pulse)	1	Black	LD10	Ramp Enable	Required
Input (Pulse)	2	Brown	LD11	Ramp Operate	Required
Input (Continuous)	3	Red	LD12	Door Full Open	Required
Input (Pulse)	4	Orange		Reset Controller	Optional
Power Supply	5	Yellow		+24 V Supply	10 A Time Delay Fuse
Power Ground	6	Blue		Ground	Required
Input (Pulse)	7	Violet/Yellow	LD13	Close All Doors	Required
Input	8	Violet/Green	LD14	Extra	Optional

All Connections on this Connector Optional (929.505-6 Amp Connector)					
Function	Pin #	Wire Color	LED	Description	Restrictions
Input	1	Green		Relay Power (+24 V)	10 A Time Delay Fuse
Output	2	Purple		N.C. Ramp Enabled	
Output	3	Grey	LD17	N.O. Ramp Enabled	Required
Output	4	White		N.C. Open Door	
Output	5	Black/White	LD18	N.O. Open Door	Required
Output	6	Black		N.C. Ramp Malfunction	
Output	7	Red/White	LD19	N.O. Ramp Malfunction	
Output	8	Orange/Red		N.C. Clear Signal	
Output	9	Yellow/White	LD20	N.O. Clear Signal	Required
Output	10	Blue/White		N.C. Manual Release Unlocked	
Output	11	Green/White	LD21	N.O. Manual Release Unlocked	
Output	12	Red/Black	LD22	N.O. Ramp alarm	
Power Ground	13	Gray/Pink		Ramp alarm ground	
Not Used	14				
Not Used	15				
Not Used	16				
Not Used	17				
Not Used	18				

Ramp to Controller Connections (T1730-S14 Thomas & Betts Connector)					
Function	Pin #	Wire Color	LED	Description	Restrictions
Input	1	Yellow/Red	LD6	Pressure Mat Return	
Power	2	Green/Black		Ramp + 24 V	
Power	3	Orange/Black		Ramp Ground	
Input	4	Orange	LD1	Ramp full out sensor	
Input	5	Green/Black	LD2	Ramp full in sensor	
Output	6	Red/White	LD29	Drive Motor +	
Output	7	Yellow	LD30	Drive Motor -	
Input	8	Blue	LD3	Ramp full up sensor	
Input	9	Yellow	LD4	Ramp full down sensor	
Not Used	10				
Not Used	11				
Input	12	Brown	LD5	Ramp manual release sensor	
Output	13	Black/Red	LD27	Elevate motor +	
Output	14	Orange/Red	LD28	Elevate motor -	

Operation

Pre-Operation Notes

Operation Procedure Review:

The RA200 operator should review all safety precautions and all operation procedures appearing in this manual prior to attempting to operate ramp. Failure to do so may result in serious bodily injury and/or property damage.

Operate the ramp through all functions to ensure the proper use and operation of the ramp is clearly understood. Be sure to review the manual operation procedures, particularly the proper re-engagement procedure of the manual cable release system (see page 10). Any questions or concerns should be forwarded to your Braun representative.

Do not operate the ramp if it is suspected to be damaged, have excessive wear, or any abnormal condition. Discontinue use immediately and contact an authorized Braun representative.

Preventative Maintenance:

Maintenance is necessary to ensure safe and trouble-free ramp operation. General preventative maintenance consisting of inspecting, cleaning and lubricating procedures should be part of a scheduled routine. Simple inspections can detect potential ramp operational problems. Adjustments can be made as needed (details in Maintenance and Adjustments section).

Regular preventative maintenance will reduce potential ramp operation downtime and increase the service life and reliability of the ramp, as well as enhancing safety. Exposure to harsh weather elements, environmental conditions or heavy usage may require more frequent maintenance

and lubricating procedures. See the Maintenance and Adjustments section for more detailed information.

Cold Climate Recommendations:

The vehicle in which the ramp has been installed should be stored in a garage or other sheltered place if possible, especially during inclement weather conditions. When the ramp is not in use, it should be in the stowed position to prohibit rain, snow, ice, dirt, mud, or other foreign materials from entering the ramp opening or building up on the platform surface.

Ramp Operating Instructions

Ramp Operating Instructions address the required controller inputs and the corresponding ramp functions. Instructions for customer specific display panels and interlock options will not be addressed due to the boundless variations in application and installation of the ramp. Manual Operating Instructions are addressed in the event of power or equipment failure.

Before Operating Ramp: Always park the vehicle on a level area, away from vehicle traffic. Place the vehicle transmission in "Park" and engage the park or emergency brake.

Customer Interlock: The ramp controller requires a (+) 24V signal be supplied which interlocks the ramp functions with a customer supplied vehicle signal. If this interlock signal is not present, the controller will not provide any outputs necessary to operate the ramp. If the interlock signal is lost during ramp operation, the platform assembly will automatically complete the 'full stow' sequence,

and the controller will not function any further until the interlock signal is present once again.

Operator Input Switches: The RA200 electronic controller provides fully automatic operation of all ramp functions, which are protected by the obstruction sensing feature. Ramp functions can be performed from any position the platform assembly happens to be in at the time the operator input switch is activated.

Two-Way Toggle Operation:

In two-way toggle mode, there are separate switches for deploy and stow functions. One of the switches must be pressed and held or locked into position (continuous input signal required) for the RA200 to operate. The ramp will move in the selected direction until the switch is released (signal interrupted), the unit reaches the end of the travel, or a "halt condition" occurs (details follow).

Halt Conditions: Several conditions can cause a normal sequence to terminate (stop):

- Obstructions (details below)
- Customer Interlock signal lost (see Customer Interlock)
- Manual Release System 'unlocked' signal present (see Manual Operating Instructions: Mechanical Method)
- Control Box Manual Input Switch pressed (see Manual Operating Instructions: Electrical Method)
- Weight sensed on platform

Obstructions: The controller performs obstruction sensing (see RA200 Terminology: Obstruction Sensing) on all stow and deploy movements of the ramp (in, out, up, down), whether operated normally or with the manual override switches. The selected obstruction response mode configured

in the controller during installation immediately stops movement when obstructed. Once an obstruction has halted the ramp, the controller automatically resets and awaits operator input for further operation.

Note: The ramp will sense an obstruction and halt with any substantial weight on the platform (built-in safety feature). The ramp will continue when the weight is removed from platform.

Operation Functionality

The 100465-002 easy ramp control box incorporates a Microchip PIC microcontroller that executes a sequential program from a built-in flash memory. This section gives a brief overview of the operational functionality that the firmware provides in the operation of the ramp.

One-Touch Operation: A momentary pulse input from an operate button will start an automated deployment sequence. The user does not have to continue to press the operate button for the ramp to complete its motion. In a similar manner, the user need only push the operate button once again to start a stow sequence.

Ramp Enable: The ramp must first be enabled by applying a momentary pulse signal to the ramp enable input (momentary push-button switch). Once enabled, the “Ramp Enabled” normally open (N.O.) output is activated. Then, the ramp may be operated using the “Ramp Operate” button. The ramp is automatically disabled when the platform becomes fully stowed at the end of a cycle. The ramp may also be disabled if the enable push-button is pressed again.

“Close All Doors” Input: An optional input, “Close All Doors,” may be used to cause a stow sequence. This input is also a momentary pulse input. At the completion of a stow cycle, the control box will de-activate the “Open Door” output. The door should then automatically close.

Opening Door: The control box opens the door using the “Open Door” output. For the duration of the ramp deployment and stow cycle, the door shall never be allowed to close. At the completion of a stow cycle, the control box will de-activate the “Open Door” output. The door may automatically close or close after the driver signals the door to close. If the door fails to open after an 8 second timeout period, the “Open Door” output will be deactivated and the ramp will not be deployed.

Obstruction Sensing: The control box can sense if the ramp platform is obstructed during movement using a pressure mat and over-current circuitry. If one of these detection techniques occurs, the ramp is halted. If three consecutive obstructions during the deployment cycle occur, the auto-stow feature described in Section 3.10 will execute.

Pressure Mat Detection: The top surface of the ramp platform is covered with a weight or pressure sensitive mat. If a passenger is on top of the platform, the ramp will not move when activated. If the ramp is already in motion and weight is applied to the platform, the ramp will halt its motion. Additionally, the platform may be equipped with a pressure sensitive edge strip that senses obstructions at the leading edge.

The leading edge obstruction strip would be wired with the pressure mat and therefore behave similarly.

Ramp Alarm: Prior to any motion of the ramp, an alarm output is activated for a few seconds. The alarm output sounds for the duration that the ramp platform is not fully deployed or fully stowed. This continuous output is used to power an audible alarm and/or lights. For the lights to flash, a special harness (ER1320A) is used with a built-in flashing unit.

Manual Operating Instructions

The RA200 has the capability of being manually operated (mechanical or electrical methods). If you experience power or equipment failure, refer to the step-by-step instructions to manually operate the ramp. Always use extreme caution when operating the ramp manually. Read all Manual Operating Instructions carefully and thoroughly prior to performing manual operating procedures. Follow all Ramp Operation Safety Precautions at all times.

Mechanical Method

Cable-Activated Manual Release System: A cable activated manual release system disengages (unlocks) the carriage assembly drive chains to allow the platform assembly to be manually extended or retracted as required. A T-handle is provided on the release cable for activation of the manual release system (details follow).

After manually extending or retracting the platform assembly, it is extremely important that the cable-activated manual release is positively reengaged to secure (lock) the platform assembly before loading a passenger or continuing vehicle use (details provided). **Failure to reengage and secure the platform may result in unintended ramp movement, which may result in serious bodily injury and/or property damage.**

Manual Release System Security Sensor: A proximity sensor detects when the cable-activated manual release system is disengaged (unlocked) and provides a ground (-) "unlocked" signal to the controller. The unlocked signal disables all controller functions so that the mechanism can be manually operated without the risk of

injury. The unlocked signal may also be used to supply a visual display to the operator that the ramp is unlocked and must be secured prior to any additional operation of the ramp or vehicle.

Note: The unlocked sensor LED is not supplied (customer installed).

Self-Locking Release Pin: A self-locking release pin allows the platform assembly to be disconnected from the elevation mechanism, allowing a raised platform to be manually lowered in the event of a power failure. See Photo below. The release pin should only be used when the platform will not lower under electric power, as stated in the Electrical Method section (next).

To Manually Extend or Retract Ramp:

1. Turn (loosen) the manual release "T" handle 90°.
2. Pull the "T" handle fully outward (3" to 4").
3. Turn (tighten) the "T" handle 90° to secure handle in the disengaged (unlocked) position.

Self-Locking Release Pin



4. Verify mechanism is disengaged (unlocked). View customer installed sensor LED.
5. Carefully move the platform in or out to desired location using the platform Hand Hold.

Reengage Carriage Assembly by Drive Chains:

1. Position the ramp platform manually so that only 15 cm is extended out of the cassette.
2. Turn (loosen) the manual release "T" handle 90°.
3. Push the "T" handle fully inward until handle contacts shaft shoulder (3" to 4").
4. Grasp the platform Hand Hold and move the platform slightly outward until **platform locks** into position (secured by reengaging the carriage assembly with the drive chains). **Note:** Do not push platform inward to lock as it may then create a binding condition in the release mechanism and will not release easily in the future

⚠ WARNING



Push T-handle in fully and manually move platform in and out to engage platform lock before driving vehicle. Failure to lock platform may result in unintended platform deployment. Unintended platform deployment may result in serious bodily injury and/or property damage.

81823

Do not remove!

5. Turn (tighten) the “T” handle 90° to secure handle in the engaged (locked) position.
6. Verify mechanism is reengaged (**locked**). View customer installed sensor LED, or pull on the Hand Hold to ensure no movement occurs.
7. Stow the remaining portion of the platform by using the electrical system.

To Manually Raise or Lower Ramp:

1. Raise and hold platform assembly up to gain access to the self-locking release pin.
2. Carefully remove release pin, using caution as the platform assembly may now move freely (unhindered).
3. Manually raise or lower the platform assembly as desired.
Note: The release pin will only be able to be reinstalled when the platform assembly is returned to the original position in which the pin was removed.

Electrical Method

Control Box Manual Input

(Override) Switches: Manual input switches are located inside the electronic control box. **Do not use manual input switches to operate the ramp when loading or unloading a passenger.** These momentary contact switches are provided as an override for **maintenance and service purposes only**. Manual input switches should be activated by qualified technicians only.

A service technician can use the manual input (override) switches to move the carriage assembly with problems due to debris build up, wear or mechanical binding (obstruction sensing will not

allow normal ramp operation). The switches can also be used in event of an electrical problem remote from the ramp electrical system (such as a problem with a vehicle installed control switch or interlock circuit).

Note: There must be power to the ramp system (electronic controller) in order to use the manual input (override) switches.

Each respective override switch can be used to move the ramp platform in the stated direction (as labeled); OUT (extend), IN (retract), UP (raise or elevate) or DOWN (lower). The IN and OUT switches use the control logic to limit the travel to the maximums as set by the respective sensor pickups. **Caution!** The UP and DOWN switches are **not limited** to the sensor pickups, and thus manual over travel can occur. Over travel may result in damage to ramp components or **serious bodily injury** if not used with extreme caution.

Note: A ramp operating under normal conditions via an operator’s input switch will halt in the event a manual input override switch is pressed. Once released, the controller will automatically reset and function normally when the next operator’s input switch signal is received.

Maintenance, Lubrication & Adjustments

Exterior Maintenance and Lubrication

Note: In order to ensure proper and consistent performance of the Braun RA200, routine maintenance in the form of cleaning, lubricating, inspecting, and adjusting is essential.

The following items can be accessed after deploying the platform, and without the removal of either the top or bottom cover.

Cleaning/Lubrication: All exterior parts of the ramp, accessible during stow or deploy, may be cleaned with high pressure water, with exception of being pointed directly into the cassette or at the electrical connectors along the exterior

frame. A de-greasing agent and brush may be used if necessary to remove large buildups. **Do not** spray water directly into cassette or at the electrical connectors. Clean away debris that may be built up in beeper that may reduce or prohibit audibility.

Ramp Platform Hinge: Clean and lubricate the ramp platform hinge. A light oil may be used on the hinge, but should be limited to reduce the possible buildup of debris. See Photos C and D. Allow hinge to dry before applying lubricant (light oil).

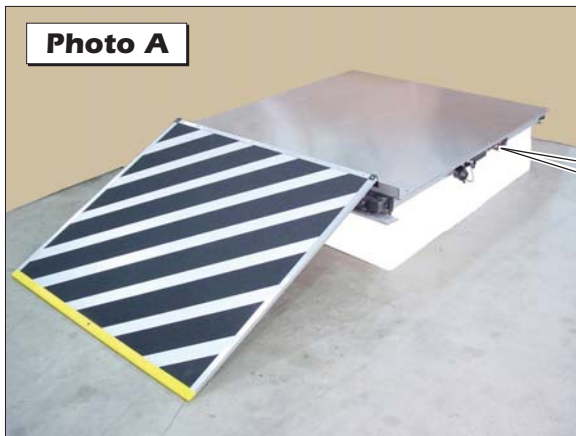

Overall View of Deployed RA200

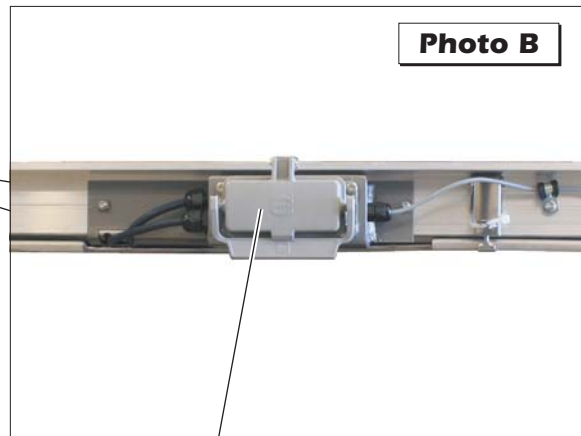

Electrical Connector

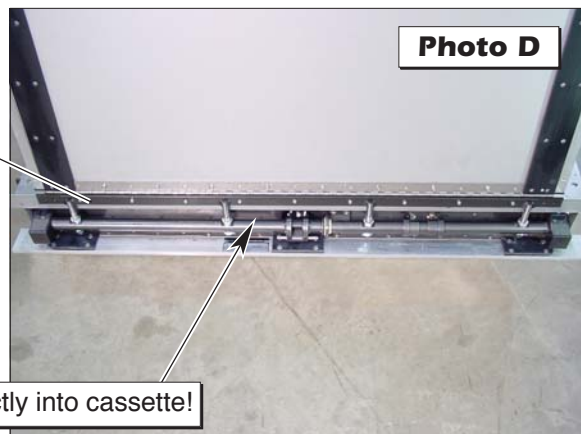
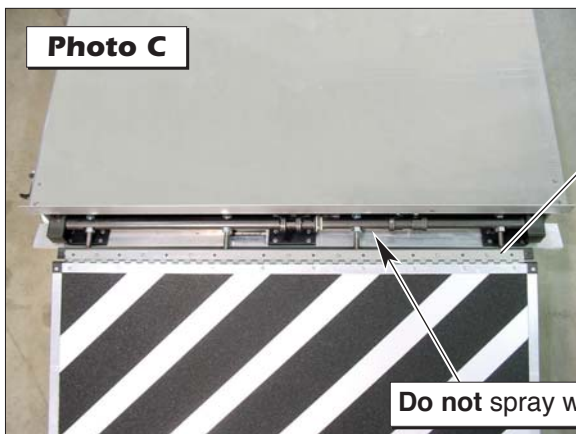

Maintenance, Lubrication & Adjustments

Exterior Maintenance and Lubrication (continued)

Front Cover Hinge: The front cover opens and closes via a spring loaded hinge. See Photo E. Clean and lubricate the front cover hinge. A light oil may be used on the front cover hinge but should be limited to reduce the possible buildup of debris. Allow hinge to dry before applying lubricant (light oil).

Manual Release Handle: The manual release handle locks in position via a quarter turn of the handle. Clean exterior then unlock and pull handle out to apply lubricant (light oil) to shaft. Cycle handle in and out to distribute lubricant throughout mechanism.

Front Cover Seals: The front cover seals are important in order to reduce the amount of debris which enters the cassette during non-operation of the ramp. Inspect seals, clean and replace if necessary.

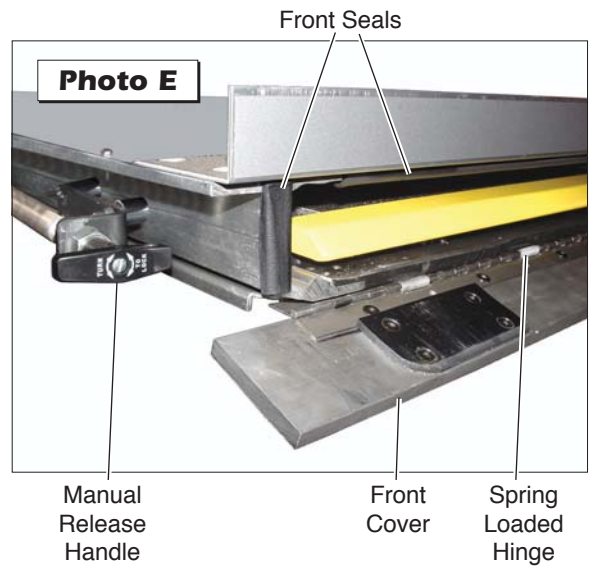

Clean and Apply Light Oil

Exterior Adjustments

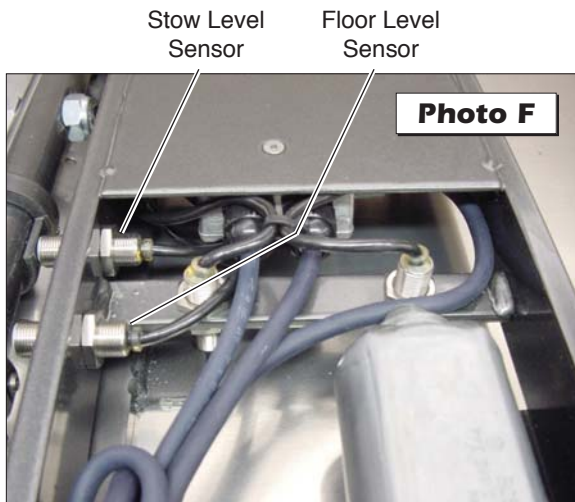

Floor Level/Stow Level Position of Platform: Vital to ramp performance is proper platform position before, after and during deploying and stowing cycles. Proximity sensors (see Photo F) use a magnetic field to switch on and off as the

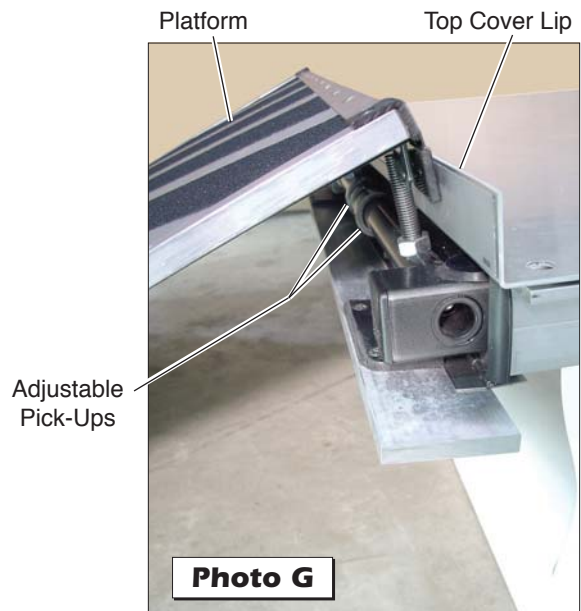

metallic pick-up passes in front of the sensor head. Distance from the sensor head to the pick-up must be approximately 2 mm and should be checked to ensure sensor switching (sensor LED lights when switched on). See Photos H and I.

Maintenance, Lubrication & Adjustments

Exterior Adjustments (continued)

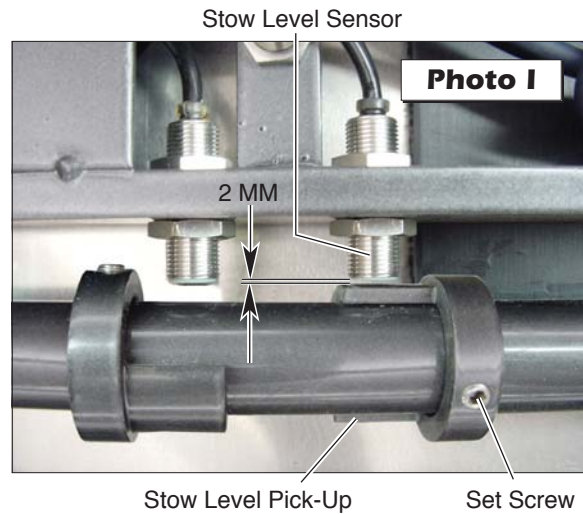
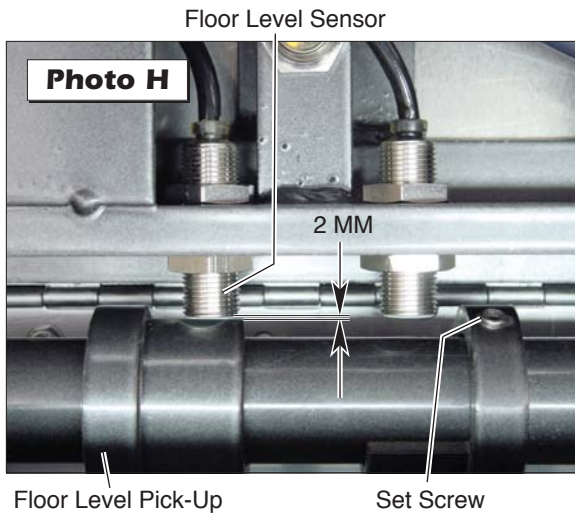

1. The floor level (up) sensor pick-up (see Photo H) should be adjusted (via the set screw) so that the elevation motor stops once the platform has gently touched against the top cover lip (see Photo G on page 13), or vehicle threshold if further from the center of the vehicle. Incorrect setting of this pick-up could result in a large gap between the platform and the threshold (too low) or in the ramp retracting into the stowed position due to obstruction sensing (too high).

2. The stow level (down) sensor pick-up (see Photo I) should be set (via the set screw) to allow a smooth transition of the ramp platform into the cassette. Ramp skid pads, located on the back corners of the ramp (see Photo J), reduce friction at the point where the ramp corners contact the top of the guide rail. See Photo K. Carefully observe the ramp skid pads when adjusting the stow level sensor pick-up. **Note:** An incorrect setting of the stow level could result in excessive wear, premature failure, or the shearing off of the ramp skid pads (pads are replaceable).

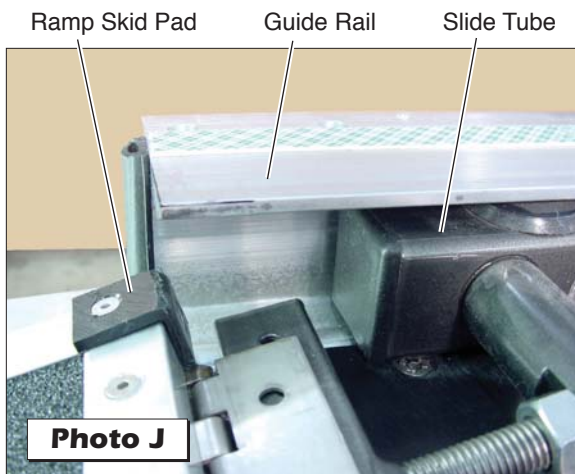

Maintenance, Lubrication & Adjustments

Exterior Adjustments (continued)

Floor Height: Variable height adjustments are made by screwing the four threaded bar ramp supports in/out to achieve the desired floor level height. Once initially set during installation, this height should not require altering. Two items to note.

1. When increasing the height, the maximum is achieved when the ramp toe contacts the inside of the front cover (see Photo M). If the maximum is surpassed, the front cover will remain partially open when the ramp is in the fully stowed position, thus allowing foreign material and debris to enter the cassette.
2. When decreasing the height, the non-used portion of the threaded studs must be cut off to maintain proper clearance for main axle rotation (see Photo N). Failure to do so may result in the inability of the platform to lower to stow level due to a binding condition of the main axle, possibly causing damage to the elevation motor.

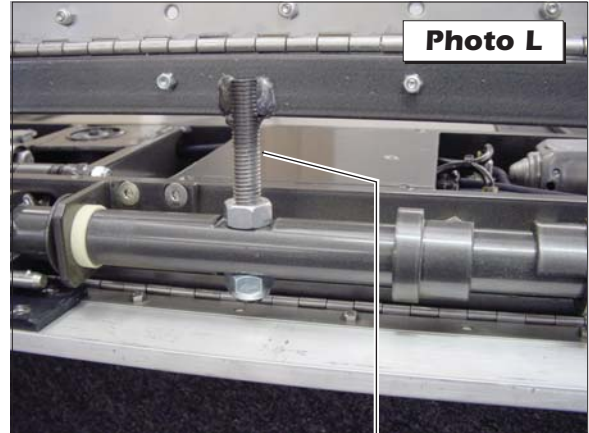

Lift ramp to access bolts.

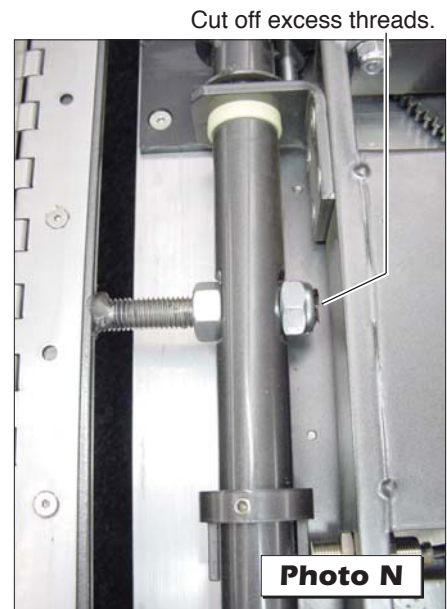

Maintenance, Lubrication & Adjustments

Interior Maintenance and Lubrication

The following items can be accessed through the interior of the ramp by removing either the top or bottom cover.

Bottom Cover: The snap-on bottom cover can be removed for easy access. The bottom cover is easily removed via two draw latches on each side (see Photo P), along with four bolts across the front (see Photo O). When replacing, make sure to install a new tie wrap on the latches in order to secure the bottom cover. Inspect the bottom cover seals and replace when necessary.

Top Cover: Only remove the top cover when deemed absolutely necessary to obtain access to specific parts not available via the bottom cover. Remove the ramp mounting hardware and lower the ramp assembly in order to remove the top cover. Replace the double sided foam tape seal whenever the top cover is removed.

Cleaning and Lubrication: All interior parts of the ramp, accessible via the top or bottom cover, may be cleaned with high pressure air only. Use a cleansing cloth to wipe away debris deposits and large buildups.

Ensure guide rails are clean and free of all debris. Carriage track rollers are sealed and do not require lubrication.

Note: Ramp controller includes an **Obstruction Sensing Feature**. Debris build up or obstructions (rocks, sand, dirt) in the guide rails can result in the ramp stopping or reversing direction during in-out functions (if obstructed). Again, ensure the guide rails are clean.



Bolts Securing Front Cover



Draw Latch

Tie Wrap

Maintenance, Lubrication & Adjustments

Interior Adjustments

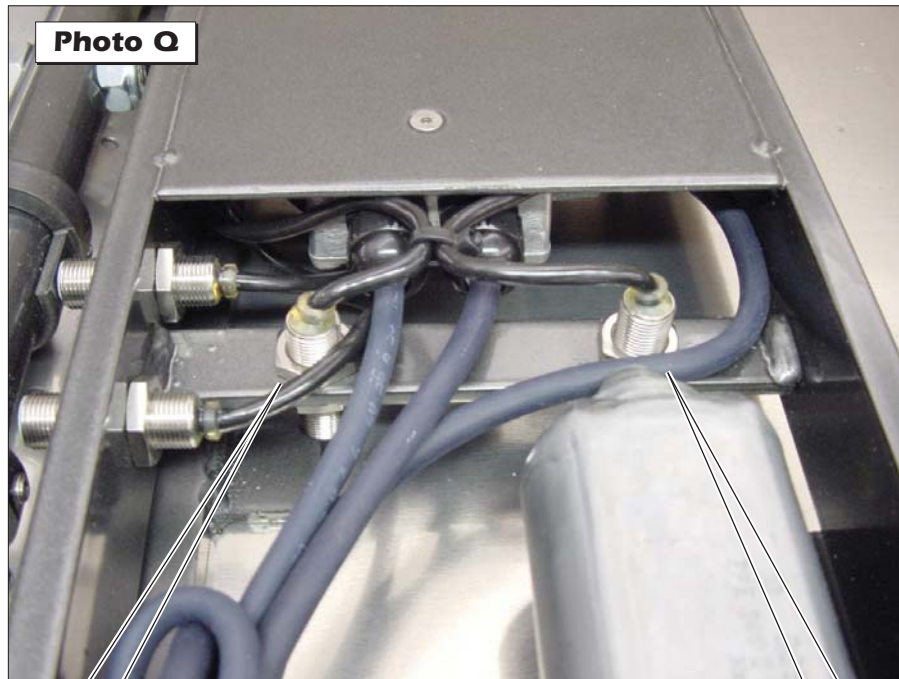

Overall View



Full Out/Deployed Positional Sensor

Pick-Up Plate



Full In/Stowed Positional Sensor

Pick-Up Plate

Full In/Full Out Position of Carriage: The carriage houses two sensors that provide positional feedback of full out (see Photo R) or full in/stowed (see Photo S) for the carriage and platform assembly. The proximity sensors switch on and off as the sensor head passes over a metallic pick-up plate mounted on the cassette frame. Distance from the sensor head to the pick-up plate must be approximately 4 mm and should be checked (due to possible loosening) to

ensure sensor switching (sensor LED lights when switched on). **Note:** Verify the full out sensor is distanced properly to remain lit (switched on) during the entire elevation cycle. If the sensor light should be intermittent during the elevation cycle, reposition the sensor to reduce the distance between the sensor head and pick-up plate, while confirming there is no interference of the sensor head and pick-up plate during the in/out movement. See Photo R.

Maintenance, Lubrication & Adjustments

Interior Adjustments (continued)

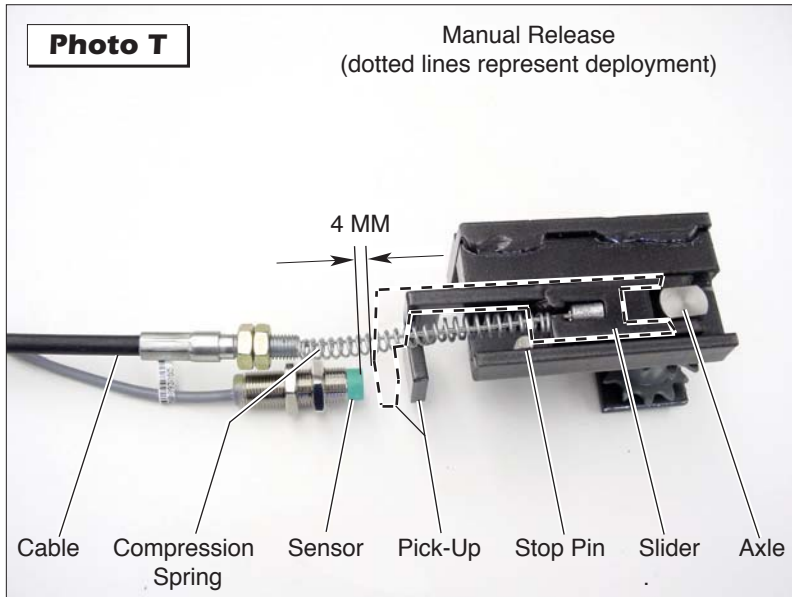

Manual Release System: If the release cable is difficult to pull to unlock the system, inspect the guide and slider shown in Photo T.

Confirm no dirt, metal shavings, or other foreign debris are present and restricting the slider. Also, check compression spring to verify the open end of the spring is not binding the movement of the slider.

Manual Release Sensor Adjustment: Inspect manual release sensor to confirm LED is lit when slider is precisely released from axle. The distance from the sensor head to the pick-up must be approximately 4mm or less at this precise point to ensure Manual Release Locked/Unlocked signal is accurate. Adjust distance by moving sensor in/out via the sensor's two locknuts. Operate several times after adjustment to confirm new setting is correct.

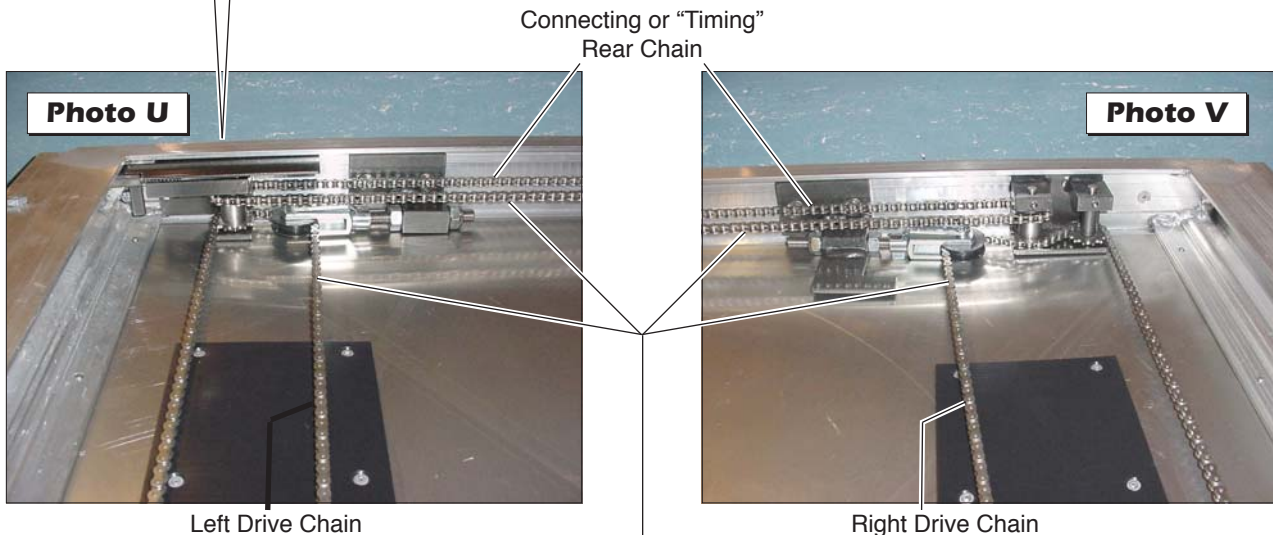

Light Oil can be applied to chains (small amount)

Chain System: The ramp utilizes a 3 chain system. Two drive chains, left and right, provide the means for the carriage to travel along. The third chain, in the rear of the cassette, interlocks the left and right drive chain to rotate in sequence (or equal time).

During normal operation, none of the 3 chains move. However, during manual operation of the ramp, all 3 chains travel equal distances. To lubricate, a light oil may be used on the chains, but should be limited to reduce the possible buildup of debris.

Maintenance, Lubrication & Adjustments

Interior Adjustments (continued)

Chain Tension: Equal tension on the left and right drive chains is necessary to reduce binding effects on the carriage bearings and allow for smooth movement throughout the in/out cycle. An excessively loose chain may enable the drive sprocket to “jump” teeth, thus providing a binding situation. Conversely, an excessively tight chain may increase the drag on the drive sprockets, and thus increase the force necessary to move the platform

during manual operation. Each respective side's chain tension can easily be modified by moving the threaded rod in or out to the desired position via a pair of locknuts (see Photos W and X).

Note: The rear timing chain tension is not adjustable. If problems arise due to the rear timing chain tension, contact your Braun representative.

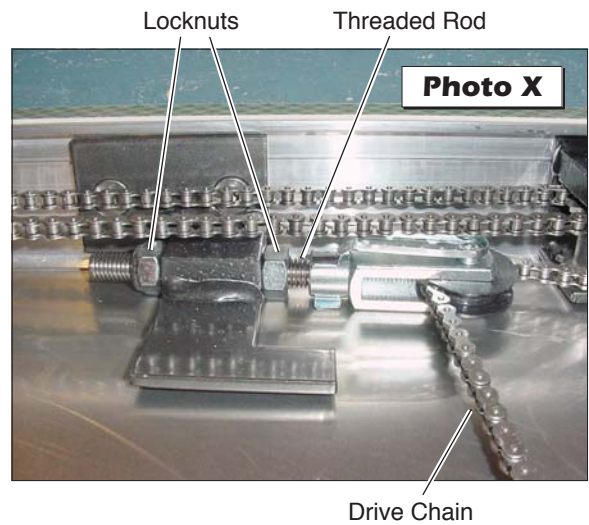
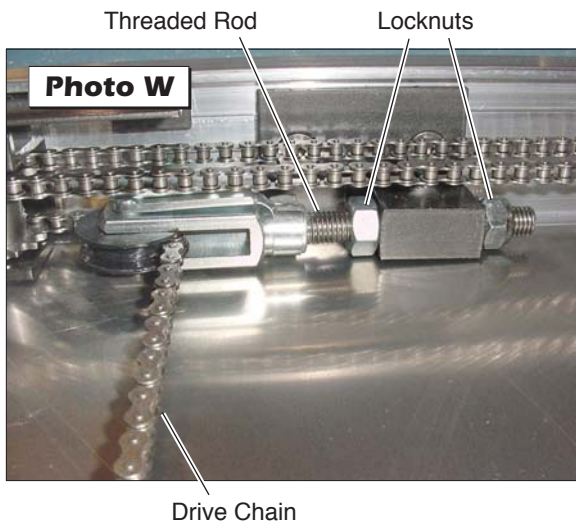

Inspection and Adjustment: Braun specifies a drive chain tension that requires a force gauge and metric tape measure for accurate setting, inspecting, or adjusting on all models of RA200 ramps. Braun recommends the Wagner Force Dial gauge model FDK 20 or FDN 100. These gauges can be found at www.wagnerforce.com.

difficult ramp operation or excessive wear/ premature failure of respective drive components.

1. Remove the bottom cover of the ramp assembly.
2. Position the ramp in the fully deployed position.
3. Measuring from the back of the carriage the distance $L_1 = 200\text{mm}$ (for all models), hook the force gauge to the outside edge of the drive chain (photo Y).
4. Pull the force gauge inward until the center of the drive chain linkage measures approximately **85mm** from the edge of the extruded housing (L_2 in photo Y). The nominal chain tension (on the force gauge) should read **5.5 kg \pm 0.5 kg (55N \pm 5N)**. Adjust the tension by tightening the respective locknuts as required. **Note:** Improper chain tension may result in poor ramp performance,

5. Repeat steps 3-4 for the opposite drive chain, again ensuring the tension force is within the recommended range.

6. Proceed with the Carriage "Full Out" Alignment to ensure proper chain tension and alignment.

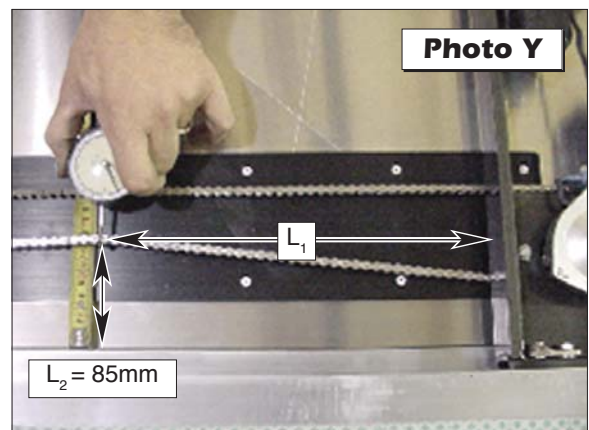

Maintenance, Lubrication & Adjustments

Interior Adjustments (continued)

Carriage “Full Out” Alignment: When the carriage is deployed to the “Full Out” position, the front bar of the carriage should align parallel with the union bar of the housing. This alignment will help ensure that a fully deployed and elevated platform will properly align with the bus threshold. Properly maintaining this carriage alignment will also help provide optimal performance during the in/out movement of the carriage and platform.

Accurate inspection of the carriage alignment can be done by measuring the distance behind each drive motor from the rear carriage bar to the rear housing (L_3 and L_4 in Photo Z). Comparing the two distances, increase the chain tension on the side of the longest distance, via the tension locknut, **1/2 turn for each 1mm difference**. Cycle the ramp several times, observing the full out alignment of the ramp with the bus threshold. Stopping once again at the fully deployed position re-measure the distance behind each drive motor from the rear carriage bar to the rear housing and adjust the chain tension accordingly until the full out alignment from side to side is within $\pm 1\text{mm}$. **Note:** If the chain tension of one side is overly increased, it may result in a binding condition of the track rollers in the guide rail and lead to obstructions sensed by the control box.

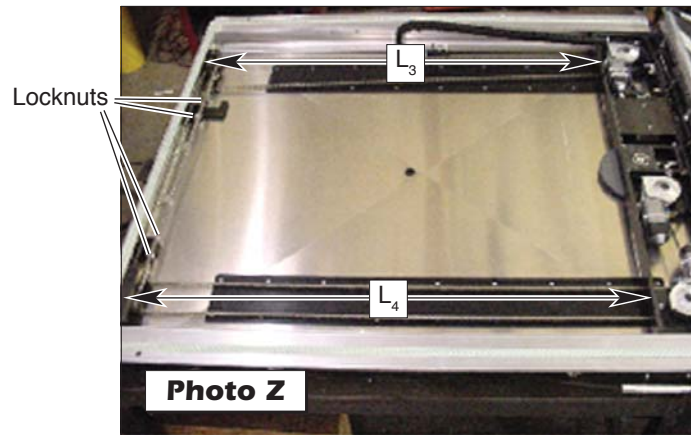

Exterior Inspection

Below is a list of routine inspections which should be done to ensure optimal ramp performance and prevent excessive wear leading to poor operation and possible component failure. Refer to the specified pages within this manual for further details. These ramp inspections should be performed if the ramp has unusual malfunctions, the bus is undergo-

ing routine service, or after every 500 completed cycles, whichever comes first. If the ramp fails to operate at a satisfactory level after performing these inspections and the accompanying adjustment or course of action, please contact your local Braun distributor or The Braun Corporation's Product Support Department for further assistance.

Inspect	For What	Action/Adjustment	See Manual Page No.
Platform	Torn or detached tape	Replace tape	15
	Proper floor level height	Floor height per ramp support	13, 14
	Proper floor level rotation	Floor level sensor pick-up	13, 14
	Proper stow level	Stow level sensor pick-up	20
	Proper floor threshold alignment	Carriage "full out" alignment	
Ramp Skid Pads	Excessive wear	Replace pad	12
	Loose rivet	Replace rivet, pad	
Front Cover	Proper closure	Inspect front cover hinge (next item) Check platform position for clearance.	13
	Excessive interference during stowing cycles	See Troubleshooting Guide	24, 25
Front Cover Hinge	Debris buildup Pin fatigue Spring fatigue/failure	Clean, lubricate Replace hinge Replace hinge	12, 13
Front Cover Seals	Debris build up Damage, fatigue & adhesion	Clean Replace seals	13
Front Cover Skid pads	Excessive wear Uncharacteristic marks	Replace pads Identify marking item and correct	13
Ramp Hinge	Debris buildup Pin fatigue	Clean, lubricate Replace	12
Electrical Connectors	Debris buildup Positive lock engagement	Clean Re-engage	12

Inspection List

Exterior Inspection

Inspect	For What	Action/Adjustment	See Manual Page No.
Beeper	Debris buildup	Clean	12
	Proper audible level	Replace beeper	
Manual Release Cable	Smooth, easy operation	Clean, lubricate cable See Troubleshooting Guide	13 24, 25
Manual Release Sensor	Debris buildup Cut or damaged lead wire	Clean Repair or replace sensor	18
Bottom Cover	Damage resulting in ramp interference	Replace bottom cover	16
Bottom Cover Latches	Secured with tie-wrap Proper compression of bottom cover seal	Add tie-wrap if missing Adjust latch "draw" hook	16
Top Cover	Debris buildup Damage resulting in ramp interference	Clean Replace top cover	16
Top Cover Seal	Proper adhesion/seal	Replace double-faced adhesive tape	14, 16
RA200 Label	Damage or lack of adhesion	Replace label	

Inspection List

Interior Inspection (with snap-on bottom cover removed)

Inspect	For What	Action/Adjustment	See Manual Page No.
Fully Deployed Carriage	Proper alignment	Carriage “full out” alignment	20
Extruded Guide Rails	Debris buildup	Clean	16
Chain	Debris buildup Loose chain	Clean, lubricate Chain tension	18 19
Manual Release Assembly	Debris buildup Restricted movement Proper sensor switching	Clean, lubricate See Troubleshooting Guide (back page) Reset sensor position	18 18
Electrical Wiring	Cut/worn wire/jacket Corroded terminal	Repair or replace Clean or replace	12
Full In/Out Sensor Pick-ups	Debris buildup	Clean	17
Bottom Cover Seals	Debris buildup Damage, fatigue and lack of adhesion	Clean Replace seals	16

Troubleshooting

Troubleshooting Guide

Problem	Possible Cause	Possible Solution
Carriage and ramp misalignment during in/out movement	Designed allowable tolerances	No action required unless other problems observed.
Deployed platform misalignment with bus threshold	Chain tension or position with carriage sprockets	Inspect/check carriage “full out alignment”
Repeating obstruction sensed during in/out movement	Misalignment of carriage Differential in chain tension Debris on extruded guide rails Mechanical interferences Low/high supply voltage Exceeded current draw limits of control box	Inspect/check carriage “full out alignment” Inspect drive chains Inspect extruded guide rails Check for identifying marks on all skid pads, etc. Check supply voltage Place controller in ‘service’ mode and cycle ramp. If no obstructions occur, return controller to ‘operating’ mode and clean and lubricate platform assembly. If obstructions do occur in ‘service’ mode, discontinue use and contact authorized Braun representative.
Repeating obstruction sensed during up/down movement	Loss of full out sensor signal Threaded bar ramp supports interfere with carriage Platform contacting floor level edge Platform contacting union bar during inward movement	Inspect sensor LED during up/down movement. If LED is intermittent, reposition sensor as required to ensure sensor remains lit during up/down movement. Cut off excess threaded bar ramp supports to allow proper clearance Reposition floor level sensor pick-up Reposition stow level sensor pick-up
Grinding/rubbing sound during in/out movement	Threaded bar ramp support rubbing on front cover skid pad Debris on extruded guide rails	Grind leading edges of threaded bar if noise intolerable Inspect extruded guide rails
Front cover remains open when platform is stowed	Hinge springs fractured Carriage/platform misalignment	Replace hinge Inspect/check carriage “full out” alignment
Manual release cable pulls too hard	Slider binding in guide	Remove slider. Check for foreign debris, metal shavings, or spring interference. Clean and lubricate.
Manually released platform pulls too hard	Left/right drive chain tension excessively high	Adjust drive chain tension.
Manual release will not reengage properly	Spring failed/has interference Slider binding in guide Manual release giving false signal	Inspect spring and correct as needed Inspect, clean and lubricate slider and guide Inspect and adjust manual release sensor position

Troubleshooting Guide

Problem	Possible Cause	Possible Solution
Ramp/controller will not respond or function to inputs properly	<p>Controller not configured properly</p> <p>Jumpers loose or fallen off controller terminals</p> <p>Interlocks not installed/connected correctly (Park, Manual Release)</p> <p>Controller relay failure</p> <p>Electrical harness failure</p>	<p>Re-configure controller</p> <p>Inspect and replace jumpers in proper configuration</p> <p>Verify interlock signals are present as required</p> <p>Inspect relays and replace if failed</p> <p>Inspect harness and replace if failed</p>
Panel binds on front cover during stowing sequence	<p>Front cover edge is hitting the screws/nuts of the platform hinge assembly</p>	<p>Adjust stow height lower</p> <p>Grind clearance for nuts</p>
Pressure mat will not respond or function properly	<p>Controller not configured properly</p> <p>Electrical harness failure</p>	<p>Re-configure controller</p> <p>Inspect harness and replace if failed</p>
Sensitivity edge will not respond or function properly	<p>Controller not configured properly</p> <p>Electrical harness failure</p>	<p>Re-configure controller</p> <p>Inspect harness and replace if failed</p>

Repair Parts

Parts List - ER1301WS Overall Exploded View

Item	Qty.	Description	ER1301WS
1	1	Carriage and Ramp Assembly	Pages 27B, 28B & 29
2	1	Frame Assembly	Pages 30, 31A & 32A
3	1	Panel, Upper	ER1265-1300
4	10	Screw, M5 x 20, Hex Head Cap	27452
5	12'	Tape 1/16" x 3/4" Double Face	82033R
6	1	Panel Assembly, Lower	ER1369A-1300GS
7	4	Washer, M6 Fender	27759
8	4	Screw, M6 x 16MM, Hex, Cap	28785
9	1	Chain, Roller, 8MM Pitch	28532R101.00
10	1	Chain, Roller, 8MM Pitch	28532R98.4375
11	1	Chain, Roller, 8MM Pitch	28532R63.625
12	3	Master Link, 8MM Pitch	27428
13	1	Sponge Strip, 1/2" x 1/4" x 40"	82062R040
14	1	Decal, Logo, Cover, Easy Ramp	28223
15	1	Decal, Upper Panel, Easy Ramp	28224
16	10	Nut, M5 Nylock	83038
17	4	Washer, M6 Lock	28787
18	10'	Tape, Cap, 1 1/2"	10416R
19	1	Control Box, Main Ramp (Not Shown)	ER1319
20	1	Harness, Main (Not Shown)	ER1318A-WS1300
21	1	Harness, Alarm (Not Shown)	ER1320A
22	1	Harness, Control Box	ER1317WSA
23	1	Alarm, 24V - Acoustic with Connection (Not Shown)	27493A

Exploded View - ER1301WS Overall

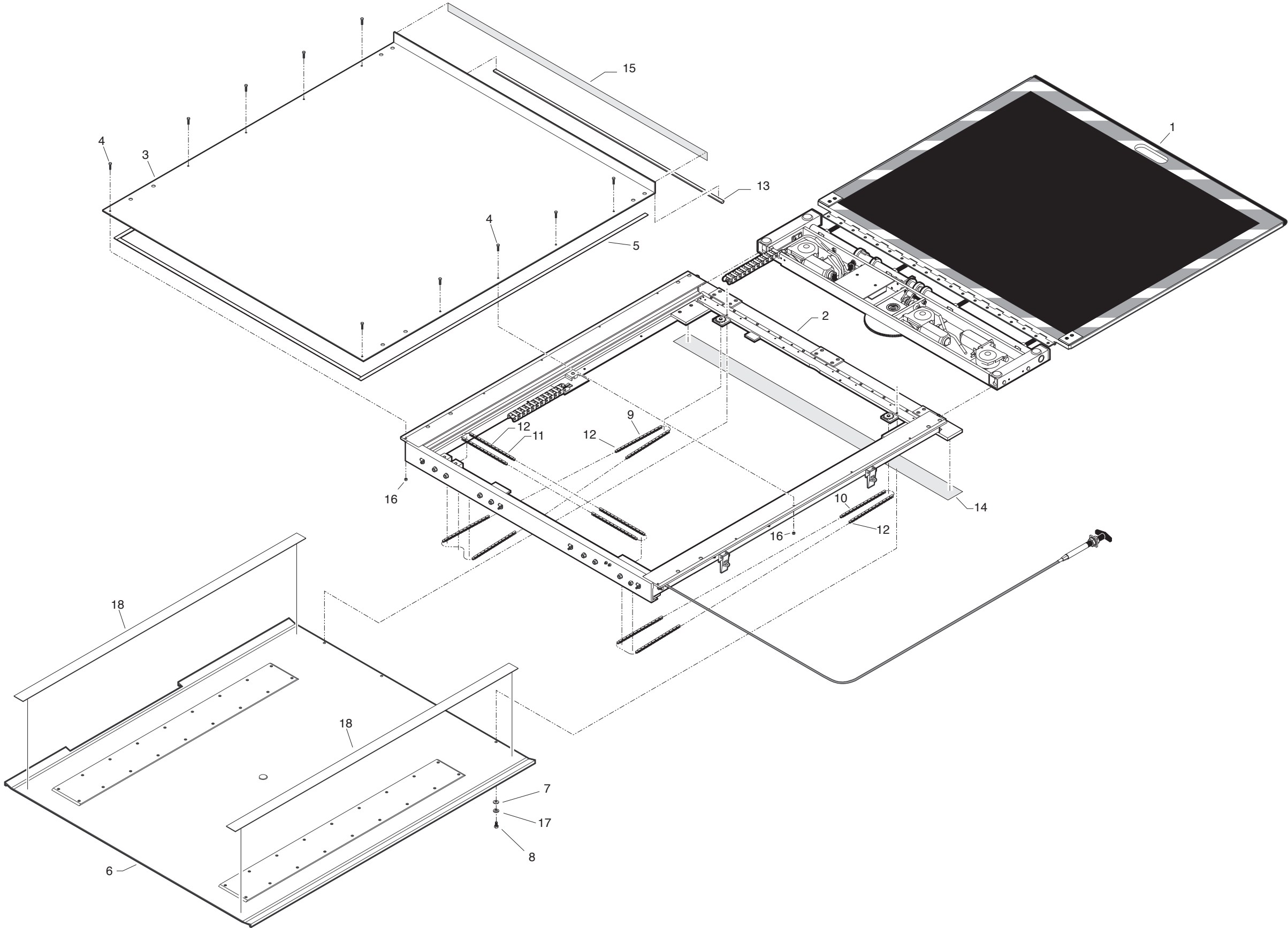

Repair Parts

Exploded View - ER1301WS Carriage & Ramp Assembly

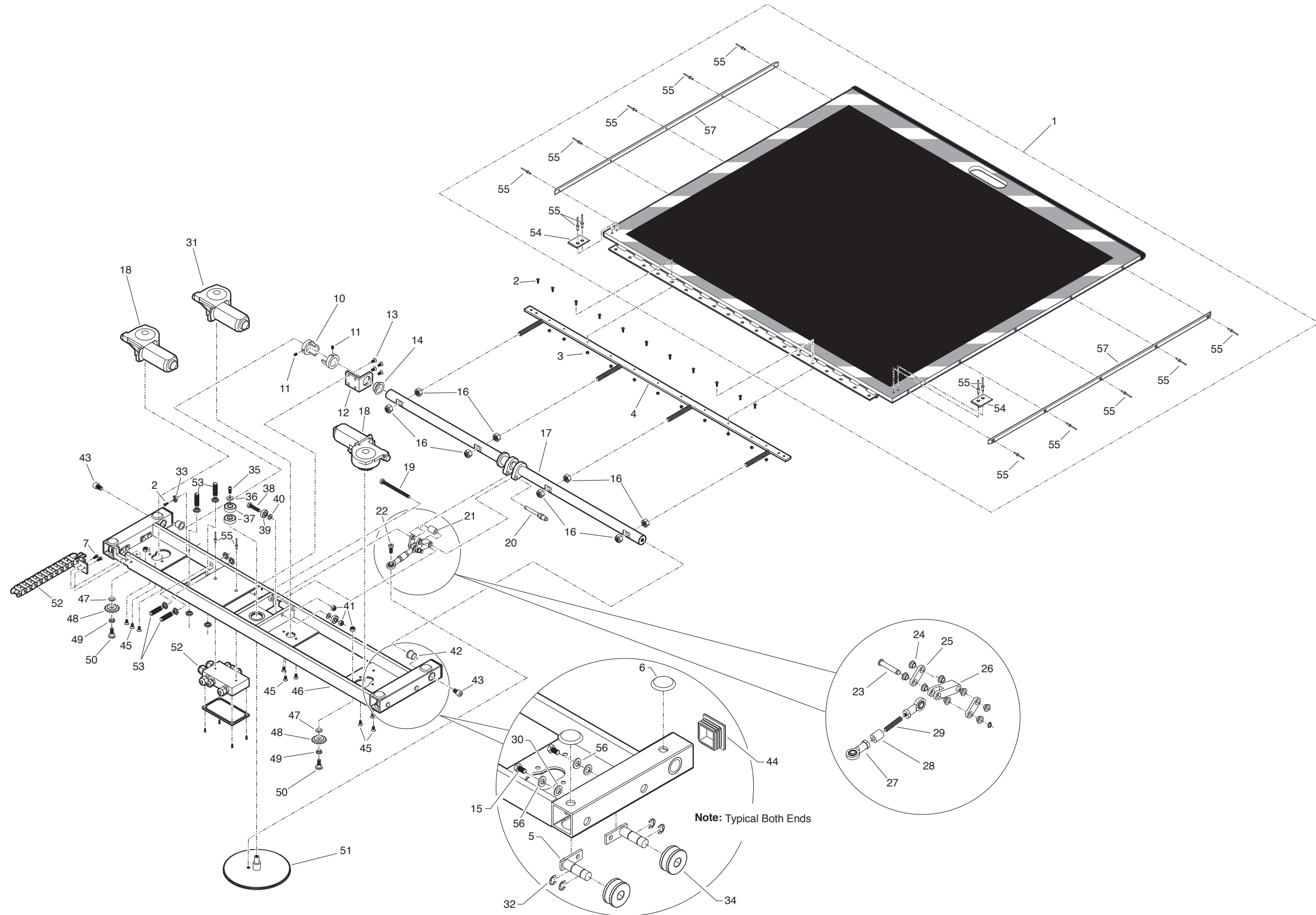

Parts List - ER1301WS Carriage & Ramp Assembly

Revised 7-10

Item	Qty.	Description	ER1301WS
1	1	Ramp Sub Assembly	ER1405A-WS1300GS
2	12	Screw, M4 x 16, Flat Socket Head, Cap - SS	33278
3	11	Locknut, M4, Nylon Insert	83037
4	1	Support Weldment, Adjustable Ramp, Carriage	ER1035W
5	4	Pin Weldment, Bearing, Carriage	ER1179W
6	4	Bearing, UHMW, 1 1/2", Flat	PS1006
7	2	Screw, M5 x 10 Hex, Cap	27449
8	NA	Tag, Serial No. / Series No. - (Obsolete - Not Shown)	NA (7-10)
9	NA	Rivet, Pop, 3/16" - (Obsolete - Not Shown)	NA (7-10)
10	2	Guide, Elevation, Main Axle	ER1086
11	2	Screw, M6 x 8, Cup Point, Socket, Set	27460
12	1	Bracket, Support, Main Axle	ER1087
13	4	Screw, M6 x 12, Flat Socket Head Cap	27458
14	1	Bearing, Plain Plastic, 1" I.D. X 1 1/4" O.D.	27777
15	4	Screw, M6 x 16, Hex	28785
16	8	Locknut, M12, Nylon Insert	22876
17	1	Axle Weldment, Main Elevation, Carriage	ER1030W
18	2	Motor, Drive Assembly, Carriage	ER1121A
19	1	Screw, M8 x 100, Hex, Cap	27465
20	1	Pin, 5/16" O.D. X 2" Grip, Self Locking	27840
21	1	Spacer, Elevation, Carriage	ER1093
22	1	Screw, M8 x 20, Socket Low Head, Cap	27762
23	1	Pin, Clevis, 5/16" O.D. X 12-3/64" Grip	27841
24	8	Bearing, Plain Plastic, 8MM I.D. X 10MM O.D.	27497
25	2	Link, Elevation, Carriage	ER1084
26	1	Yoke, Elevation, Carriage	ER1083
27	2	Joint, Ball Rod End, Elevation Linkage	27494
28	1	Spacer, Ball Joint, Carriage	ER1081
29	1	Stud, M8 x 50, Threaded	27485
30	4-8	Washer, .328" x .562" x .042" (Qty. varies)	83583
31	1	Motor, Elevation Assembly, Carriage	ER1122A
32	8	E-Clip, 7/16" Shaft, 11/32" Groove	27796
33	1	Holder, Cable Tie, 2 Way	27510
34	4	Roller, Track, 38MM OD x 12MM ID	27788
35	1	Screw, M6 x 16, Button, Socket Head, Cap	82691
36	1	Washer, M6, Fender	27759
37	2	Bearing, Ball, Elevation	27495
38	1	Screw, M8 x 35, Hex, Cap	27468
39	2	Bearing, Ball, Top Panel Support	27496
40	2	Washer, M8, Flat	27462
41	4	Locknut, M8, Nylon Insert	83042
42	2	Bearing, Plain Plastic, 16mm ID x 18mm OD	27500
43	2	Screw, M10 x 16, Socket Head, Cap	27434-SS
44	2	Plug, End Cap, 1.5" Square Tube	27843
45	9	Screw, M6 x 10, Flat Head Socket, Cap	27722
46	1	Carriage Drive Weldment	ER1225W
47	2	Bearing, Plastic Disc, 10mm ID x 18mm OD	27502
48	2	Sprocket, Drive Position, Carriage	27490
49	2	Bearing, Plain Plastic, 10mm ID x 12mm OD	27498
50	2	Axle, M8, Sprocket, Carriage	ER1085
51	1	Gear, Elevation Reduction, Carriage	27487
52	1	Harness, Electrical, Ramp	ER1318A-WS1300
53	4	Sensor, 24V, M12 x 42, Proximity	32323
54	2	Pad, Skid, Ramp, Top	ER1344
55	16	Rivet, Pop, M4 x 10, Countersunk Blind	27441
56	4	Washer, M6 Lock	28787
57	2	Pad, Alignment Skid	ER1263

Repair Parts

Parts List - ER1301WS Frame Assembly

Item	Qty.	Description	ER1301WS
1	8	Rivet, 5/32" .188" x .250" Grip	28583
2	1	Plate, Skid, Frame, Right	ER1292
3	1	Plate, Skid, Frame, Left	ER1293
4	2	Ring, 5/16", External Snap	24570
5	2	Sprocket, Fixed Guide, Manual Release	27491
6	2	Bearing, Plain Plastic, 8MM I.D. X 10MM O.D.	27497
7	1	Cover, Front, Cassette	ER1370
8	8	Screw, M4 X 10MM, Hex Head, Cap	27706
9	1	Union, Exterior Frame, Weldment	ER1210W
10	22	Rivet, Pop, SD64BS 3/16" x 13/25	11513
11			
12	8	Screw, M8 X 25MM, Flat Socket Head, Cap	27466
13	1	Slide, Manual Release	ER1245W
14	1	Assembly, Manual Release, Left	ER1041A
15	1	Assembly, Chain Tension, Left	ER1056A
16	11	Screw, M5 X 20MM, Flat Socket Head, Cap	27451
17	1	Assembly, Chain Tension, Right	ER1061A
18	1	Assembly, Manual Release, Right	ER1051A
19	25	Locknut, M5, Nylon Insert	83038
20	1	Harness, Electrical, Ramp	ER1318A-WS1300
21	3	Strap, M12, Rubber Cushioned, Steel, Loop	27435
22	7	Strap, M6, Rubber Cushioned, Steel, Loop	27456
23	8	Locknut, M8, Nylon Insert	83042
24	8	Washer, M8, Fender	27738
25	6	Screw, M5 x 10MM, Flat Socket Head, Cap	27448
26	4	Latch	ER1301
27	1	Spring, Compression	27478
28			
29	1	Cable, Manual Release, ER1301WS	34383
30			
31			
32	1	Frame, Weldment, Exterior, Aluminum	ER1305W-1300
33	2	Sponge Strip, 1/2" x 1/4" x 4"	82062R004.00
34	2	Screw, M5 x 20MM, Hex Head, Cap	27452
35	1	Cover, Plate, Manual Release Slide	ER1251
36	2	Tape, Cap, 1.5" x 2.0"	10416R002.00
37	2	Washer, .328" x .562" x .042"	83583
38	3	Plate, Skid, Front Cover	ER1072
39	1	Hinge, Cover, 1.5" x 41.5"	27425
40	1	Wire, Cover, UHMW	ER1241
41	5	Rivet, Pop, SD66BS, 3/16" x .25/.38	14993

Exploded View - ER1301WS Frame Assembly

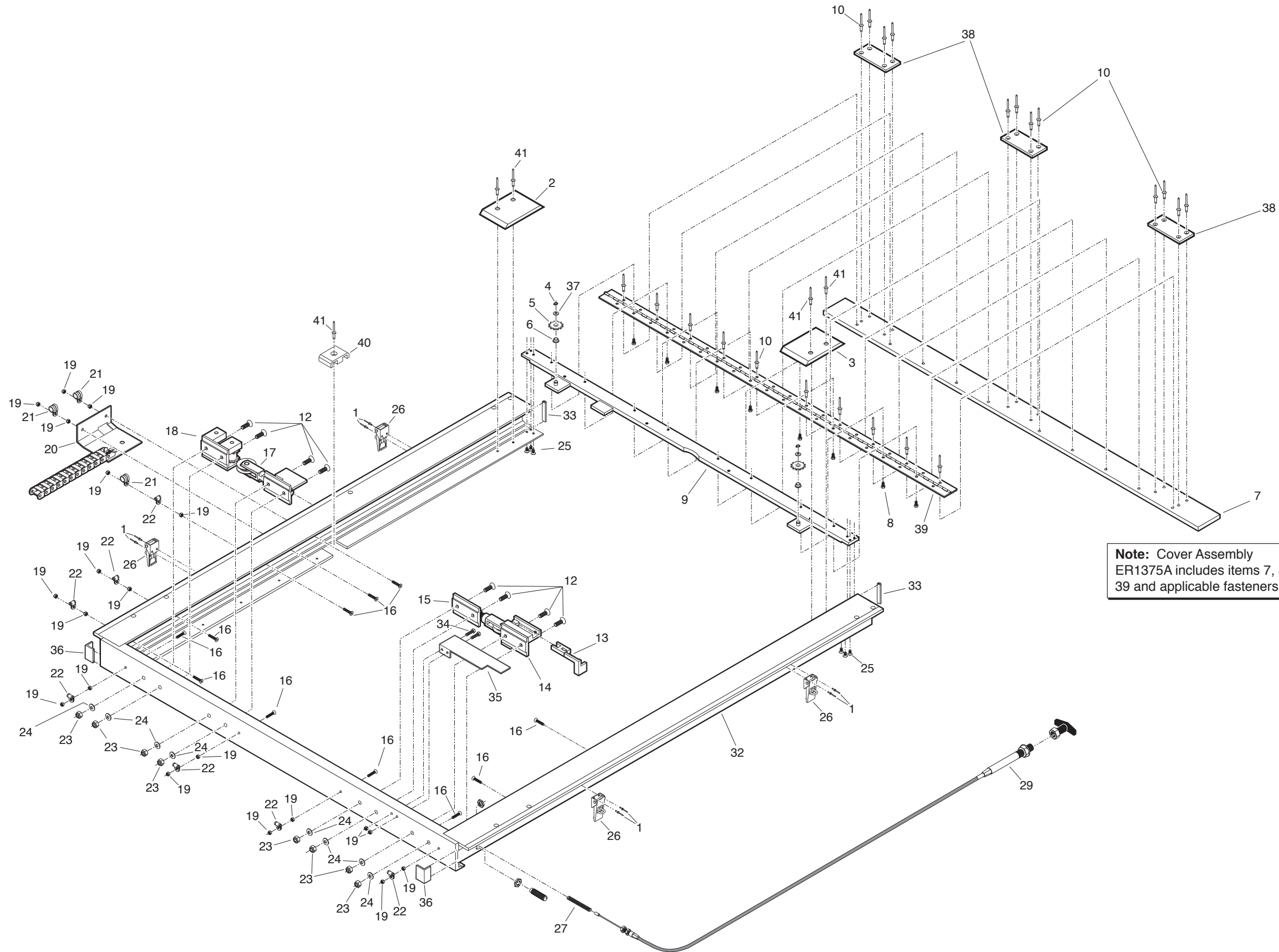

Unfold for:
Exploded View
ER1301WS Frame Assembly

Repair Parts

Exploded View - ER1301WS Ramp Subassemblies

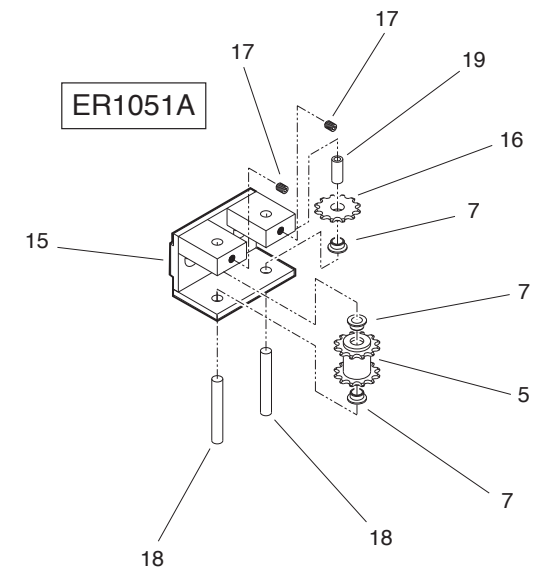
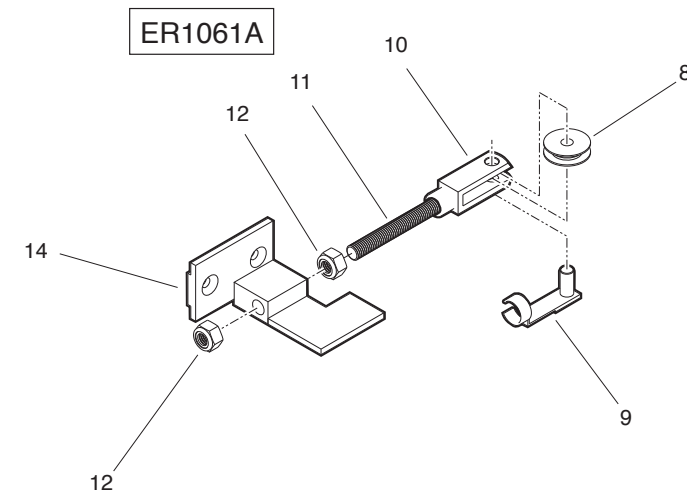
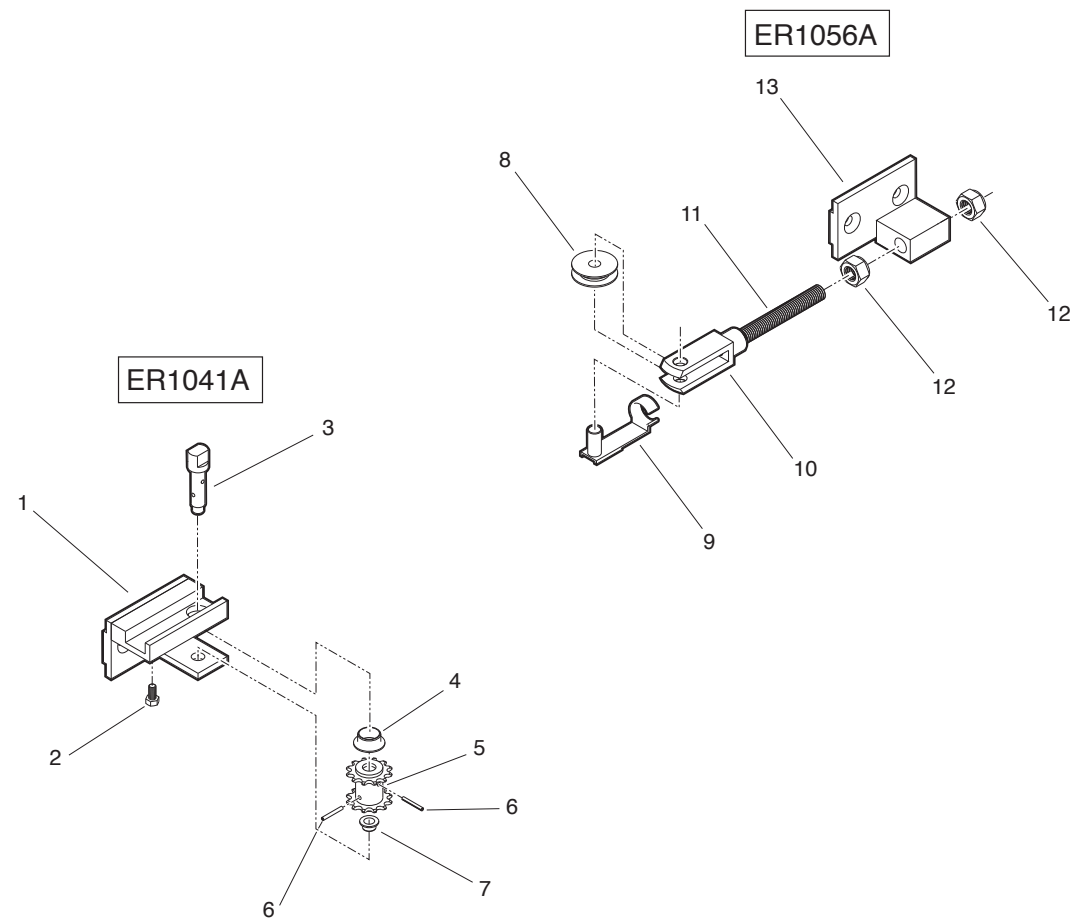

Parts List - ER1301WS Ramp Subassemblies

Item	Qty.	Description	ER1301WS
1	1	Manual Release, Weldment, Left	ER1040W
2	1	Screw, M5 x 10MM, Hex Head, Cap	27449
3	1	Shaft, Left, Manual Release	ER1037
4	1	Bearing, Plain Plastic, 15MM I.D. X 17MM O.D.	27499
5	2	Sprocket, Double, Manual Release	27488
6	2	Pin, M2.5 x 20MM, Steel Roll, Plain	27436
7	4	Bearing, Plain Plastic, 8MM I.D. X 10MM O.D.	27497
8	2	Roller, Chain Tension	ER1252
9	2	Pin, Clevis, Chain Tension	27511
10	2	Clevis, Chain Tensioner	27513
11	2	Adjustor, Threaded, Chain Tension	ER1090
12	4	Locknut, M12, Nylon Insert	22876
13	1	Chain Tension, Weldment, Left	ER1055W
14	1	Chain Tension, Weldment, Right	ER1060W
15	1	Manual Release, Weldment, Right	ER1050W
16	1	Sprocket, Fixed Guide, Manual Release	27491
17	2	Screw, M6 x 8MM, Cup Point Socket, Set	27460
18	2	Shaft, Right, Manual Release	ER1047
19	1	Tubing, .5 O.D. x .334 I.D. x 1.06"	15865R001.06



Electrical Schematic - ER1301WS Ramp Caradap Controller

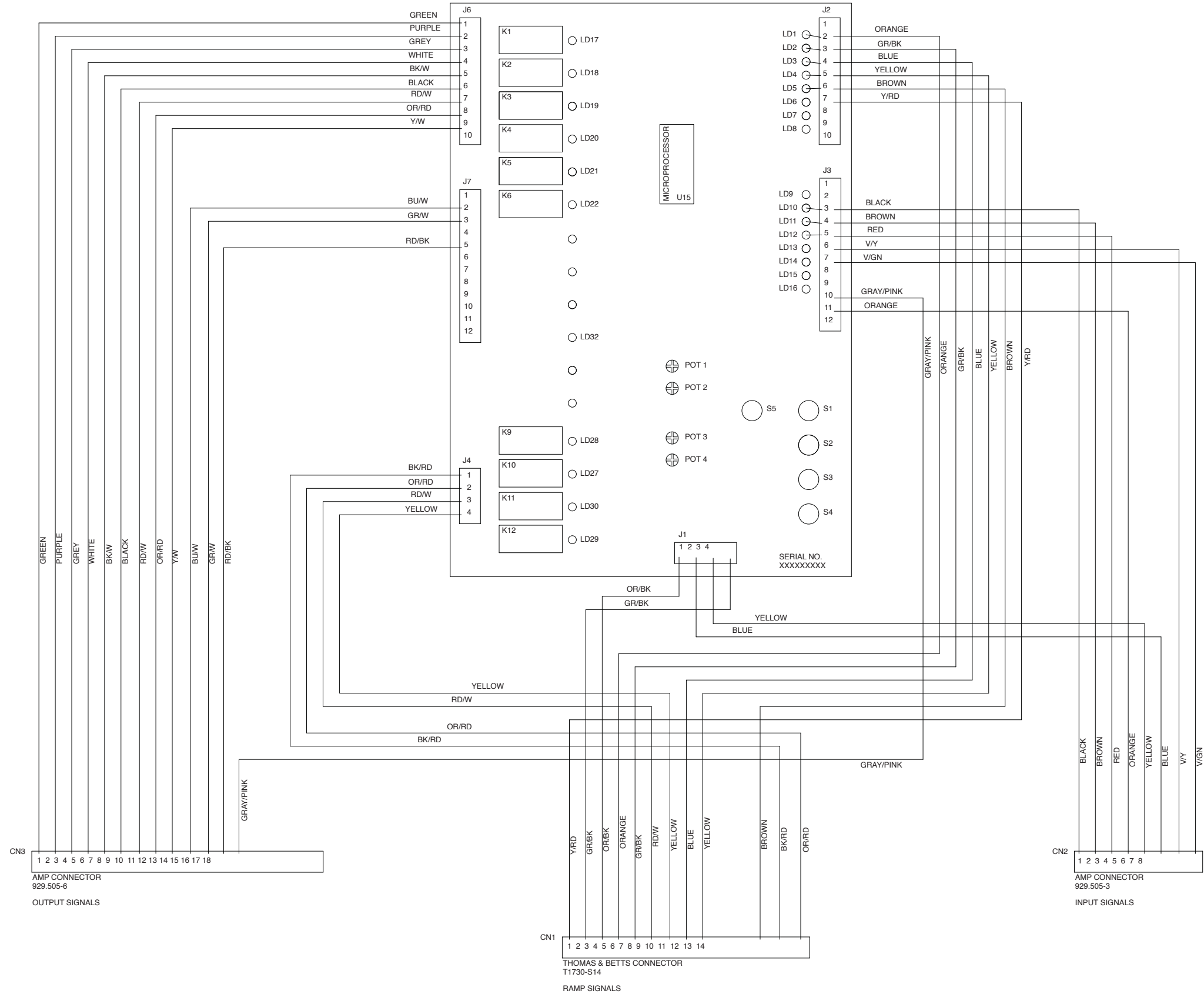

Repair Parts

Electrical Schematic - ER1301WS Ramp Wiring Harness (Caradap Controller)

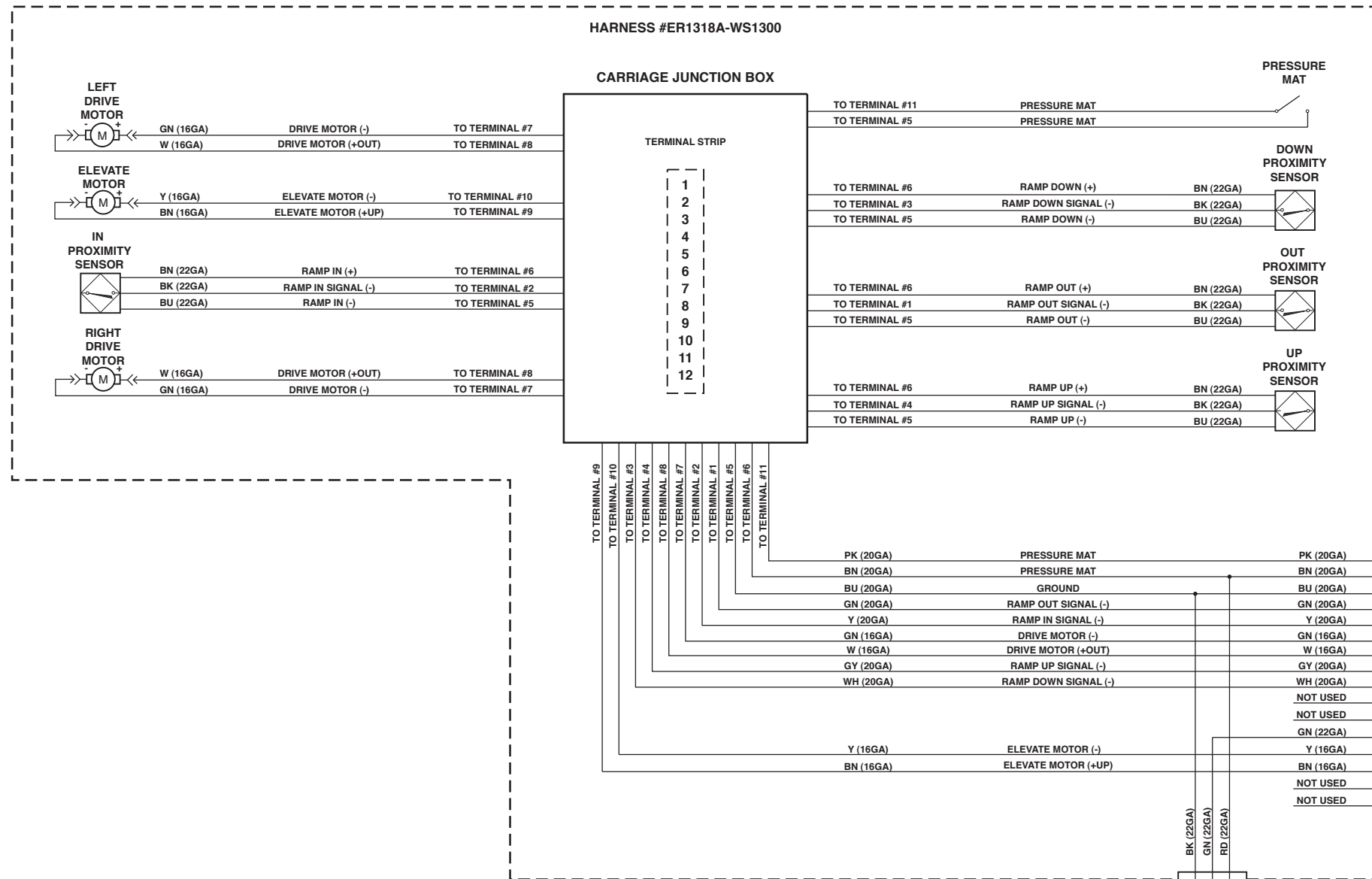

SYMBOL	DESCRIPTION
	JUNCTION
	MOTOR
	PROXIMITY SENSOR
	CONNECTORS

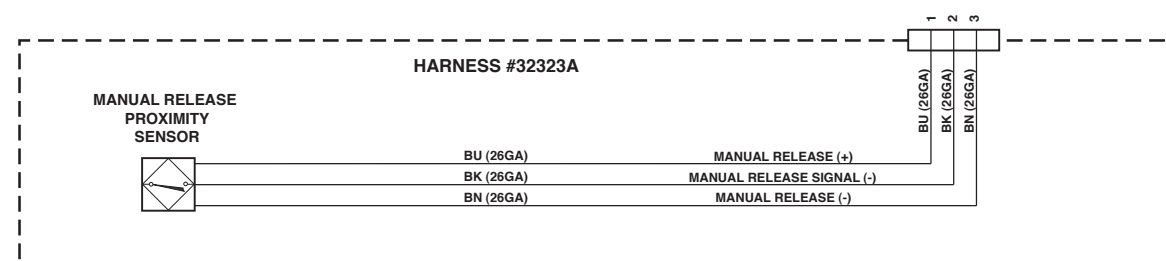
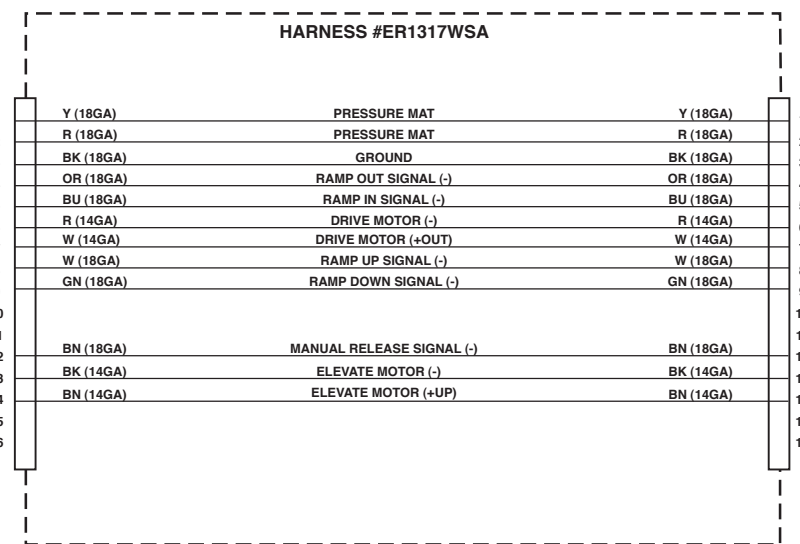
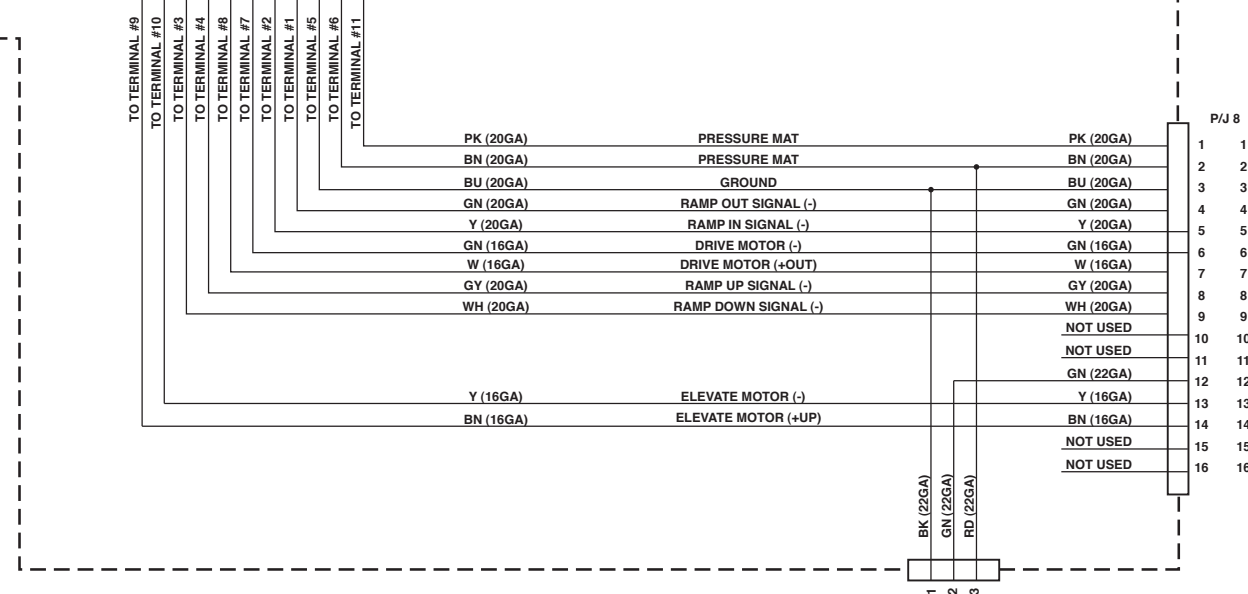

TO CNT ON CARADAP CONTROLLER #100465-002

"Providing Access to the World"



**Over 300 Braun
Dealers Worldwide**

 **THE BRAUN
CORPORATION.**
"Providing Access to the World"



International Corporate Hdqrs: P.O. Box 310 Winamac, IN 46996 USA
1-800-THE LIFT® (574) 946-6153 FAX: (574) 946-4670

BRAUN **200**TM **Transit Ramp**

with Weight Sensor & Sensitivity Edge

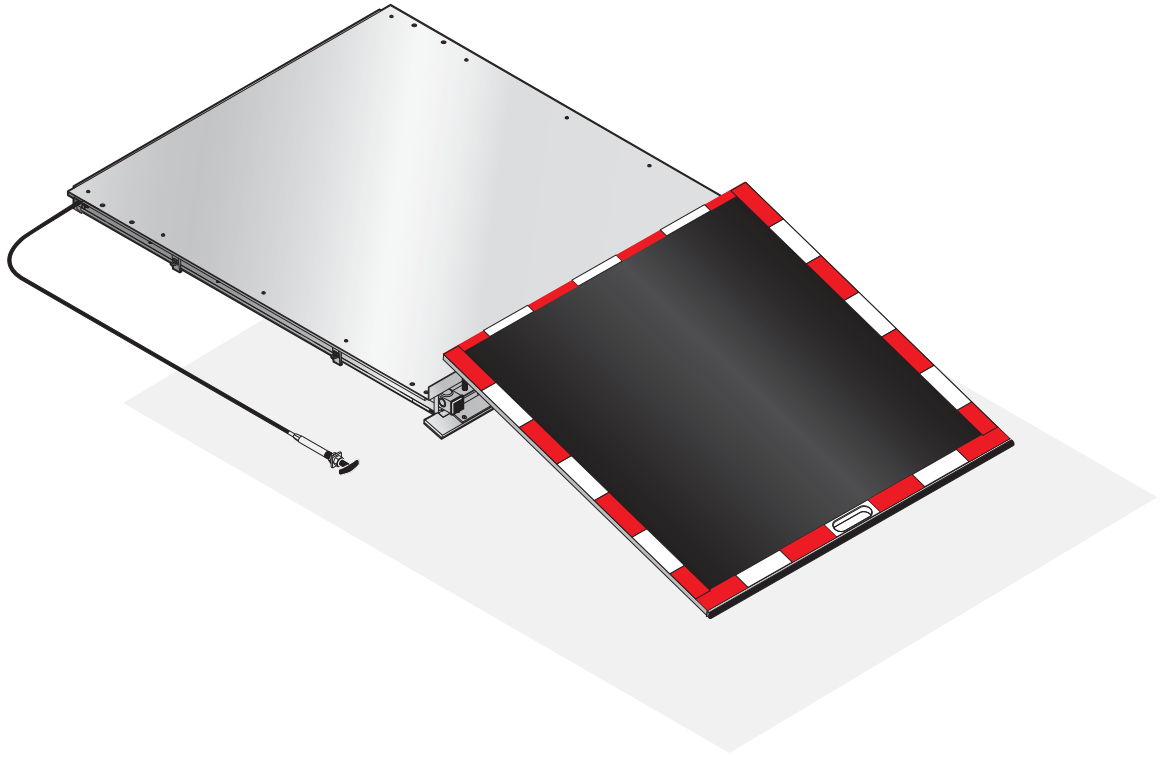

 **THE BRAUN CORPORATION**
"Providing Access to the World"[®]

International Corporate Hdqrs: P.O. Box 310 Winamac, IN 46996 USA
1-800-THE LIFT (574) 946-6153 FAX: (574) 946-4670



34952 Rev B

July 2010

Patent 7,264,433

All illustrations, descriptions and specifications in this manual are based on the latest product information available at the time of publication. The Braun Corporation reserves the right to make changes at any time without notice.