



Because Life is a Moving Experience™



2004-2010 Toyota
Foldout Rampvan®

*Operator's
Manual*

Congratulations

We at The Braun Corporation wish to express our fullest appreciation on your new purchase. With you in mind, our skilled craftsmen have designed and assembled the finest lowered floor vehicle available.

This manual includes safety precautions, operating instructions, manual operating instructions, and instructions for maintenance and lubrication procedures.

Your Rampvan® is built for dependability, and will bring you years of pleasure and independence, as long as the maintenance is performed regularly and the Rampvan® is operated by an instructed person.

Sincerely,

THE BRAUN CORPORATION

A handwritten signature in black ink that reads "Ralph W. Braun". The signature is written in a cursive style with a large, sweeping "B" and "R".

Ralph W. Braun
Chief Executive Officer

WARRANTY AND REGISTRATION	2	WHEELCHAIR AND OCCUPANT RESTRAINT	25-34
INTRODUCTION	3	SEAT REMOVAL AND INSTALLATION	
RAMPVAN OPERATION QUICK REFERENCE GUIDE	4, 5	Front Seats (General Information)	35
FEATURES	6, 7	Front Seat Wiring Harnesses	36, 37
SAFETY PRECAUTIONS	8	Front Seat Removal and Installation Instructions	38, 39
OPERATION		Third Row Power Seat Operation	40
Terminology	9	Third Row Power Seat Removal and Installation Instructions	41-43
One-Touch Control System	9	Third Row Non-Power Seat Removal and Installation Instructions	44, 45
Control Switches	10-13	PREVENTIVE MAINTENANCE	46, 47
Ramp Access Sliding Door	14, 15	JACKING AND TIRE CHANGING INSTRUCTIONS	48
Kneel System	16, 17	REPORTING SAFETY DEFECTS	49
Power Ramp Operation	18, 19	BELOW FLOOR OBSTRUCTIONS	50, 51
Power Ramp Safety	20	TOWING	52
Power Ramp Manual Operation	21		
Ramp Safety (General)	22-24		

WARRANTY AND REGISTRATION INSTRUCTIONS

Examine your Rampvan® for any damage. Should any damage have occurred during delivery, notify the carrier at once with any claims.

The warranty/registration card shown here is supplied with each Rampvan®. Review the delivery checklist and fill out the warranty registration information with your sales representative and mail it to The Braun Corporation.

The **warranty card must be processed to activate the warranty.** See the Warranty Booklet for detailed terms and provisions applicable to this vehicle.

Record the last eight digits of the vehicle identification number (VIN) in the space provided for future reference. **This information must be provided when filing a warranty claim or ordering parts.**

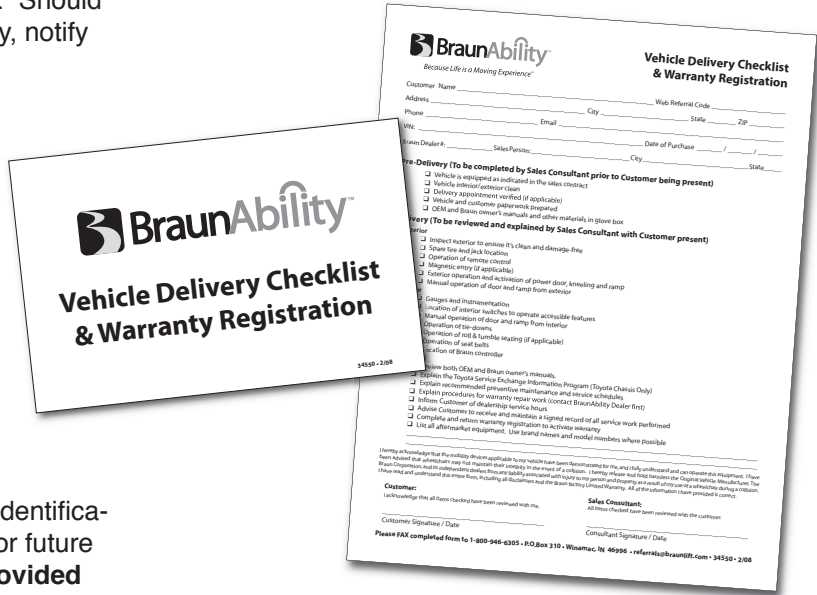

Vehicle Identification Number (VIN) _____

The Braun Rampvan® lowered floor conversion is designed to provide years of pleasure and mobility independence. Familiarity with proper operation and maintenance procedures will help ensure safe, trouble free operation.

The Braun Corporation encourages wheelchair passengers and their attendant(s) to review the material contained in this manual with your Rampvan® sales representative, **before attempting operation**. Any questions or concerns can be answered by your sales representative at that time.

This manual addresses Rampvan® standard features as well as options. Refer to the instructions applicable for your package, and disregard the information that does not apply.

The Rampvan® Operation Quick Reference Guide hanging on the mirror provides a condensed explanation of Rampvan® operation (shown at right). Read the guide and then insert it in this manual for future reference. **Note:** An Operation Quick Reference Guide (overview) section is provided on pages 4 and 5 of this manual also.

Contact The Braun Corporation at 1-800-THE LIFT® if any of this information is not understood.

Store this manual in the vehicle along with your Toyota owner's manual.

If you experience an operation problem or there is any sign of wear, damage, or other abnormal condition, contact your sales representative or call The Braun

Corporation at 1-800-THE LIFT®. One of our national Product Support representatives will direct you to a Braun authorized service center.

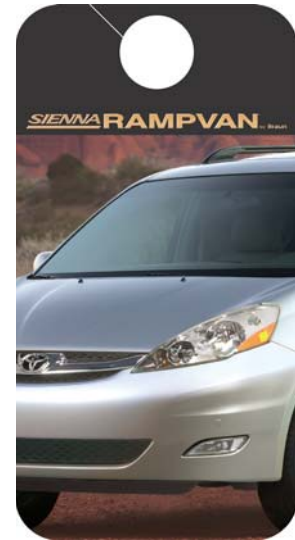

Operation Quick Reference Guide

RAMPVAN OPERATION QUICK REFERENCE GUIDE

Rampvan® Operation Overview

This overview provides a simplified explanation of Rampvan® operation. Read the entire owner's (operator's) manual for complete details. Contact The Braun Corporation at 1-800-THE LIFT® if any of this information is not understood.

Power Operation

Rampvan® power functions are managed by the One-Touch electronic control system. The control system can be activated using the Toyota remote keyless entry transmitter, any one of the interior control switches or the optional magnetic entry. Details on pages 10-13.

Toyota Remote
Keyless Entry
Transmitter



Press and
release this
switch.



Interior mounted control switches display one of these graphics.



One-Touch Control Activation

Rampvan® power door, kneel functions and power ramp are activated by **pressing and releasing** any control switch.

Open Functions: When activating the Open functions, the power door opens, the kneel system lowers the rear of the vehicle and the ramp unfolds.

Close Functions: When activating the Close functions, the ramp folds, the kneel system raises the rear of the vehicle and the power door closes.

Manual Operation

In event of power or equipment failure, the door, ramp and kneel system can be manually operated. Read this manual for further details.

Operating Your New Rampvan® Couldn't Be Simpler . . .

1 Just press any one of the buttons like the one pictured below (or any interior control switch). . .

Press and release this switch.



2 And the sliding door opens. . .



3 The rear suspension lowers. . .



4 The ramp unfolds. . .



5 Allowing easy entrance!



FEATURES

One-Touch Electronic Control System:

The Rampvan® One-Touch electronic control system provides simple one-touch activation of all Rampvan® power features. For your convenience, the control system can be activated using the Toyota remote keyless entry transmitter, any of the interior mounted control switches or the optional magnetic entry (control switch photos and details are provided on pages 10-13).

Power Passenger Side Sliding Door:

The One-Touch electronic control system activates the Toyota passenger side power slide door for ramp access. The slide door and lowered floor configuration provides 54-1/4" clear vertical passageway. **Note:** The driver-side sliding door is lowered to provide clear passage also.

Ramp: Fully automatic power ramp is available in 29 1/2" usable width.

Electromechanical Power

Kneeling Rear Suspension:

"Kneeling" is the lowering motion of the electromechanical rear suspension. The kneel feature reduces the slope of the ramp when deployed.

Lowered Floor from Rear Axle to Firewall:

This feature provides additional headroom (59" floor-to-ceiling at center of van), and further reduces the slope of the ramp when deployed. Carpeting is featured throughout the lowered floor area. **Ground Clearance:** The lowered floor results in reduced ground clearance. Be aware of limited ground clearance.

Ground Effects: Exterior color-matched ground effect panels conceal the lowered floor and lowered sliding doors.

Forward-Facing Wheelchair and Occupant Belt/Track System:

One Forward-Facing Wheelchair and Occupant Belt Kit is supplied for the restraint of one wheelchair and occupant. The belt kit is used in conjunction with the floor track. **Note:** Additional belt kits can be purchased (option).

Floor Track for Wheelchair and Occupant Securement in Midpoint Lowered Floor Area:

Floor track provided in the midpoint lowered floor area (Position C) can be utilized for restraint of wheelchair passenger(s). Wheelchair capacity at midpoint may have limitations based on the dimensions of specific wheelchairs.

Quick-Release Front Passenger Seat with Floor Track for Wheelchair and Occupant Securement:

The passenger seat (Position B) is equipped with quick-release seat attachments (making seat removal and installation procedures simple). The seat can be removed and the seat location can be utilized by a wheelchair occupant (floor track provided).

Driver Seat: For the wheelchair occupant who chooses to drive the Rampvan®, this seat (Position A) can be removed and adaptive driving systems custom tailored for the individual can be purchased from and installed by your local mobility dealer. The driver's seat is available with quick-release seat attachments. 57" floor-to-ceiling headroom is provided at both front seating positions.

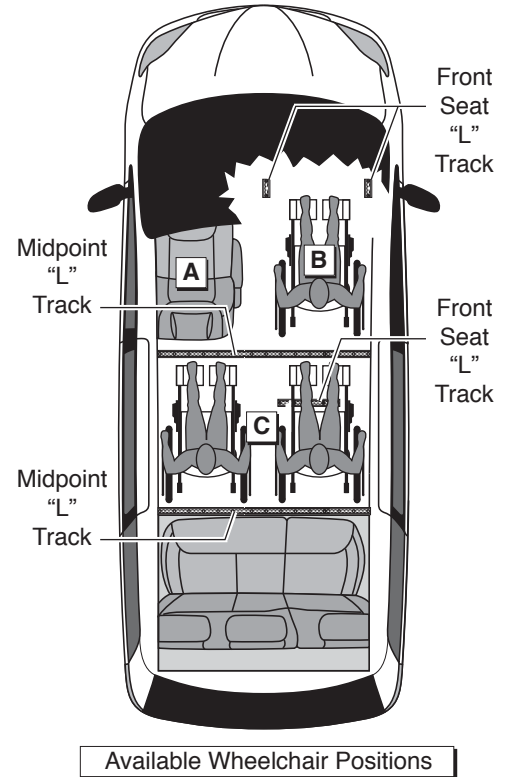

SAFETY PRECAUTIONS

Safety Symbols

SAFETY FIRST! Know That....

A All information contained in this manual and supplements (if included), is provided for your safety. Familiarity with proper operation instructions as well as proper maintenance procedures are necessary to ensure safe, trouble free operation. Safety precautions are provided to identify potentially hazardous situations and provide instruction on how to avoid them.

B



C

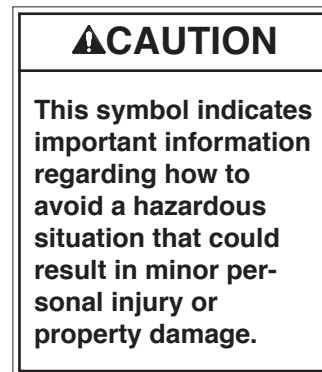

D **Note:** Additional information provided to help clarify or detail a specific subject.

These symbols will appear throughout this manual and may appear on labels posted on your Rampvan®. **Recognize the seriousness of this information.**

Whenever parking your Rampvan® and before utilizing Rampvan® features, always engage the vehicle transmission in Park “P” and engage the vehicle parking brake. The vehicle transmission **must** be engaged in Park “P,” before operating the Rampvan® automatic features. Rampvan® power function control switches cannot be activated if the vehicle transmission is not in Park.

Terminology

“Kneeling” is the lowering motion of the Rampvan® electromechanical rear suspension. The term “Deploy” indicates the lowering motion of the ramp to the deployed position. “Stow” is the raising motion of the ramp to the vertical (stowed) position.

The terms “Open” and “Close” refer to sequences of power functions that will occur when activated by the One-Touch electronic control system. When activating the Open functions, the power door opens, the kneel system lowers the rear of the vehicle and the ramp unfolds. When activating Close functions, the ramp folds, the kneel system raises the rear of the vehicle and the power door closes.

One-Touch Control System

Rampvan® power functions are managed by a One-Touch electronic control system. The control system can be activated using the Toyota remote keyless entry transmitter or any one of the controls addressed on pages 10-13.

Do not attempt to interface aftermarket control systems.

Braun Corporation Aftermarket Control Systems Policy:

The Braun Corporation manufactures dedicated control systems for its products. These control systems have been designed and tested for use in conjunction with specific Braun products. Braun control systems are the **only** control systems authorized for use with Braun products.

Do not attempt to interface aftermarket control systems without authorization from The Braun Corporation. **To do so may result in serious bodily injury and/or property damage.**

OPERATION

Control Switches

For your convenience, the Rampvan® One-Touch electronic control system can be activated using the Toyota remote keyless entry transmitter, any of the interior-mounted control switches or the optional magnetic entry (details follow).

One-Touch Control Activation

Rampvan® power door, ramp and kneel functions are activated by **pressing and releasing** any specified control switch.

Note: The Slide Door Off switch must be in the raised position to activate Rampvan® power functions (see page 12).

Remote Keyless Entry Transmitter

Using the Toyota remote entry transmitter eliminates the need for an additional remote control.

Toyota
Remote
Keyless
Entry
Transmitter



Press and release this switch.



Center Console Switch

For front seat passengers, a switch is located on the driver side of the center console.



Press and release this switch.

**PWR
DOOR**

B-Pillar Switch

A switch is located on the wall panel ahead of the passenger side slide door (B-pillar).



Press and release this switch.

**PWR
DOOR**

C-Pillar Switch

A switch is located on the wall panel behind the passenger side slide door (C-pillar).



Press and release this switch.

**PWR
DOOR**

Overhead Console Switch

For front seat passengers, a control switch is located in the overhead console.



Press and release this switch.



OPERATION

Slide Door Off Switch

The override switch is located on the driver lower left knee bolster. Pressing this switch in disables Rampvan® power functions. Pressing the switch again and returning it to the out position (button raised with orange band visible) enables Rampvan® power functions.



Switch IN:
Power
Functions
Disabled



Switch OUT:
Power
Functions
Enabled

Kneel On/Off Switch

The Kneel On/Off switch is located on the driver side of the center console. The Kneel On/Off switch turns the kneel system on and off **only**. The kneel switch must be in the ON position in order for the kneeling system to be activated.

Press this switch to **ON**
to activate kneel feature.

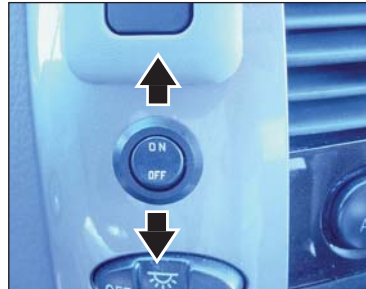

Press this switch to **OFF**
to disable kneel feature.

Magnetic Entry

The magnetic entry is offered as an **option**. A magnetic switch is built into the rear passenger-side taillight assembly. The switch is labeled OPEN/CLOSE.

A keychain-style magnet is supplied for switch activation (see photo at right). Simply align the magnet tip with the switch target (identified with decal 28013) and Rampvan® power door, ramp and kneel functions will be activated.

When activating the Open functions using the magnetic entry, there is approximately a **one second delay before** the Rampvan® Open sequence is activated. The One-Touch electronic control system unlocks all vehicle doors before activating Rampvan® power functions.

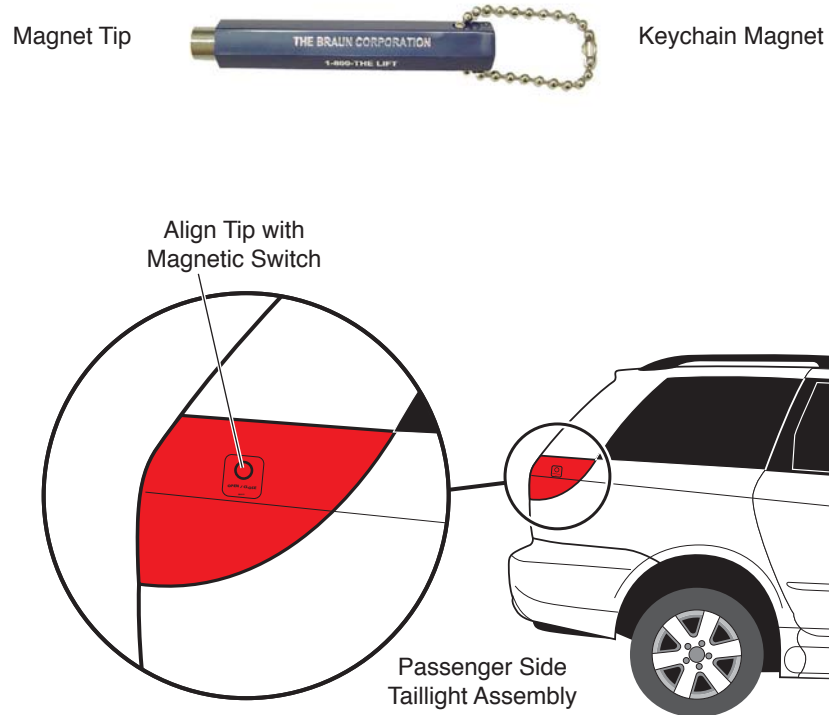

Ramp Access Sliding Door

The passenger side power sliding door may be opened using the Rampvan® One-Touch Control System or it may be opened manually. Press and release the remote keyless entry transmitter, any one of the interior-mounted control switches or the optional magnetic entry to activate the door. When a control switch is pressed, the door will open and the Open sequence will continue.

Once the Open sequence is complete (door is fully open and ramp is deployed), press and release a control switch to close the door.

The ramp stows and the door will close as the vehicle raises to complete the Close sequence.

If a control switch is pressed and released while the door is opening, the door will reverse direction and return to the closed position.

If a control switch is pressed while the door is closing, the door will continue to the closed position.

If the slide door outside handle or the interior latch is pulled while the door is opening, the door reverses direction and returns to the closed position.

If the slide door outside handle or the interior latch is pulled while the door is closing, the door reverses direction and returns to the open position.

Power Door Safety Sensor: If the power door is obstructed while opening or closing, the door will reverse direction, provided it meets sufficient resistance. If an obstruction is encountered while the door is closing, the door opens fully and stops. Press a control switch again and the door closes.

Keep clear of the area in which the power door operates.

Ensure door travel path is clear.

Be sure the door is fully closed and latched before driving.

Power Door Manual Operation: In event of power or equipment failure, unlock the passenger side sliding door. Open the slide door from inside or outside using the OEM door handles.

Note: Using excessive force or speed when opening or closing the door may cause damage to the vehicle and may cause the door to dislodge from its roller tracks.

 **WARNING**

Keep clear of area in which power door operates. Failure to do so may result in bodily injury and/or property damage.

OPERATION

Automatic Kneel System

Kneeling is the lowering motion of the Rampvan® electro-mechanical rear suspension. The kneel system lowers the rear of the vehicle. Lowering the rear of the vehicle reduces the slope of the ramp.

Kneel On/Off Feature: A Kneel On/Off feature is incorporated into the One-Touch electronic control system. This feature provides the **option** of kneeling the vehicle when operating the power door and power ramp. The Kneel On/Off switch must be in the ON position in order for the kneeling system to be activated (see photo at right). See page 12 for additional Kneel On/Off switch details.

The kneel system is automatically activated by the One-Touch electronic control system.

When a control switch is pressed to start the Open functions, the power door opens, the kneel system lowers the rear of the vehicle and the ramp deploys.

When the Close functions are activated, the vehicle starts to raise at the same time the ramp starts to retract (stow).

Note: If the Rampvan® is in the kneeled position and the vehicle is shifted out of Park, the vehicle will raise and you will hear a very rapid pulsing tone (cricket tone).

Note: If the Rampvan® is in the kneeled position and the Close functions are activated, the vehicle will raise whether the Kneel On/Off switch is on or off.

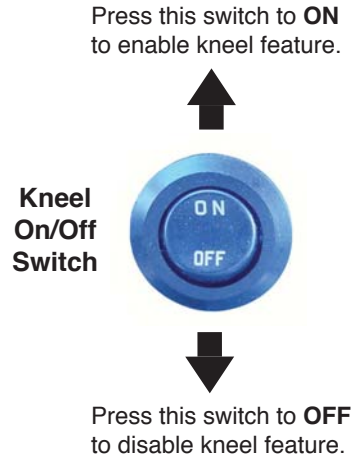

In the event the Rampvan is in the kneeled position and the kneel system is not responding to the electronic control system, have the kneel system repaired immediately. **Do not** drive your Rampvan with the rear of the vehicle in the lowered position. Attempting to do so will result in an extremely rough and unstable ride.

Contact your sales representative or call The Braun Corporation at 1-800-THE LIFT®. One of our national Product Support representatives will direct you to an authorized service center.

Kneel Electrical Override

An electrical override feature is incorporated in the kneel system. The override by-passes the electronic control system to electrically power the kneel actuator. The override is available to raise the rear of the vehicle only.

The Kneel Override Switch is located rear of the ramp in the wall panel (door post). Press and hold the switch to power the kneel system. Release the switch when the rear of the vehicle has raised fully. The kneel actuator motor will ratchet (make clicking sound).

Press and hold this switch to release kneel (raise vehicle).



Kneel Override Switch

Power Ramp Operation

The power ramp is activated by the One-Touch electronic control system. When a control switch is pressed to start the Open functions, the power door opens. Once the door reaches the fully open position, there is a slight delay before the ramp begins to deploy.

When the Close functions are activated, the ramp stows immediately.

If a control switch is pressed and released while the ramp is deploying, the ramp motor will stop running. Press a switch again and the ramp will stow and the door will close.

Once the Open sequence of

functions is complete (door is fully open and ramp is deployed), press and release a control switch to stow the ramp. If a control switch is pressed while the ramp is stowing, the ramp will reverse direction (deploy fully and stop). Press a control switch again and the ramp will stow and the door will close.

Note: If the center console Kneel On/Off switch is in the ON position, the rear of the vehicle will descend as the ramp is deploying. Inversely, the vehicle will raise when the ramp is stowing.

Manual operation of the passenger slide door handles will disable ramp deployment. To enable ramp deployment, close the passenger slide door using

the keyless entry transmitter, any interior mounted switch or the magnetic entry (if equipped).

If the power ramp is obstructed while deploying, the ramp will reverse direction and stow fully (provided the ramp meets sufficient resistance).

Forcing Ramp: Allow the power ramp to deploy (unfold and lower) fully before boarding the ramp. Forcing the ramp up or down during the deploy/stow functions, or boarding onto the ramp before it is fully deployed **may result in damage** to the ramp, the electronic controller and/or motor assembly.

Front Passenger Seat Notice: Do not recline or slide the front passenger seat to the the full

⚠CAUTION

Allow ramp to deploy fully before boarding. Failure to do so may result in damage.

rearward position when the ramp is in the stowed position. Damage to the seat can occur due to contact with the foldout ramp.

⚠CAUTION

Front seat contact with ramp may result in seat damage.

OPERATION

Power Ramp Safety: Be certain there is adequate clearance outside the Rampvan® before deploying the power ramp. Keep clear of area in which the ramp operates. Be certain no person or obstruction is within the path of the ramp when deploying or stowing the ramp. Keep clear of all power ramp moving parts. Do not attempt to grip or hold the ramp during operation. Be certain the ramp passenger is off the ramp before attempting to stow the ramp. Do not exceed the maximum weight capacity of the ramp - 600 pounds.

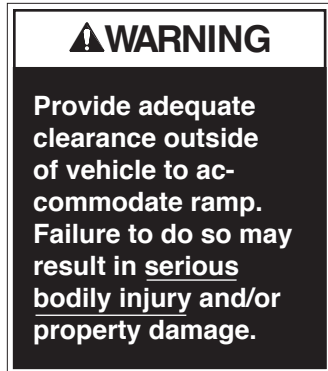

Keep body parts and obstructions clear of the area in which the ramp operates.

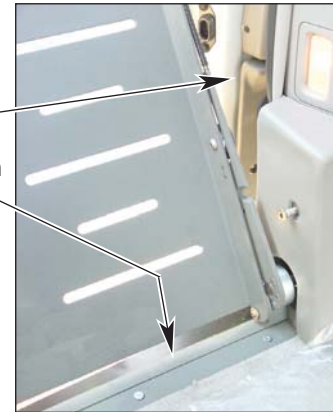

Power Ramp Manual Operation

If you experience power or equipment failure, the power ramp can be manually stowed and deployed. Have an assistant manually stow and deploy the ramp. Push ramp out **only** if assistant is not available.

Using both hands, grip the ramp bi-fold extension equal distance from center. **Carefully** deploy and stow the ramp. See Photo at right.

Keep clear of the area in which the hinged ramp bi-fold extension deploys and stows. Remember to use good body mechanics when folding and unfolding the ramp.

The safety precautions addressed in the Power Ramp Safety section also apply when manually operating a ramp. **Read and become familiar with all ramp safety precautions.**

Follow these additional precautions for manual operation of the ramp also.

Do not release the ramp when manually deploying or stowing the ramp. The ramp will free-fall.

Push the ramp out from inside the vehicle **only** if an assistant is not available. The ramp will free-fall.

Use both hands to grip ramp equal distance from center.

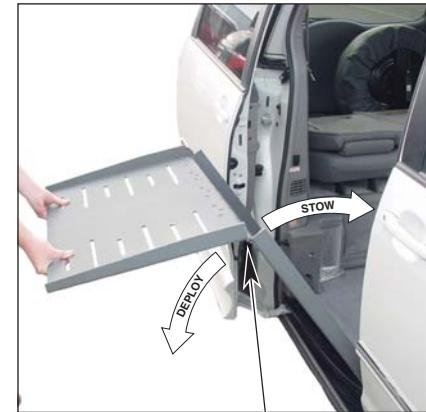

Keep clear of hinge area.

Ramp Safety

Wheelchair passengers and attendants (when applicable), must use basic common sense and good judgment regarding ramp safety. Each wheelchair passenger has a unique set of physical abilities combined with the physical characteristics of his or her wheelchair that dictate the method in which he or she will enter and exit the Rampvan®. Consequently, the procedures for safe operation outlined in this manual are general in nature. Wheelchair attendants should be instructed on any special needs and/or procedures required for safe transport of wheelchair passengers.

Follow all safety instructions regarding torso restraints, stability, balance, weight distribution and use of attendants as specified in the owner's manual supplied with **your** wheelchair. Determine, establish and practice ramp boarding and exiting procedures under the direction of your health care professional, your wheelchair representative, and your Rampvan® sales representative to **ensure your ability to do so safely**.

Never board a Rampvan® ramp if you or your attendant are intoxicated. The wheelchair should be positioned in the center of the ramp at all times. You must be able to clearly view the ramp whenever boarding and exiting the vehicle. The wheelchair passenger and/or attendant must ensure the ramp is fully deployed before exiting the vehicle.

It is the responsibility of the wheelchair operator to enter and exit the Rampvan® on the ramp in the safest manner.

Wheelchair-Equipped Occupant Seat Belts: Wheelchair passengers should position and buckle their wheelchair-equipped seat belt (torso restraint), as specified by the manufacturer, **before** loading onto a wheelchair ramp.

WARNING

Position and fasten the wheelchair-equipped occupant seat belt before loading onto the wheelchair ramp. Failure to do so may result in serious bodily injury and/or property damage.

Different types of disabilities require different types of wheelchairs and different types of wheelchair-equipped occupant restraint belt systems (torso restraint). It is the responsibility of the wheelchair passenger to have his or her wheelchair equipped with an occupant restraint (seat belt) under the direction of their health care professional.



Stabilizing Wheelchairs: Powered and manual wheelchairs are designed to remain upright and stable during normal operation. All activities which involve movement in a wheelchair have an effect on the combined center of gravity of the occupant and wheelchair. Be aware of the Rampvan® ramp slope (angle). The slope of the ramp has a direct effect on the center of gravity. Keep in mind your center of gravity and your ability to maintain stability and balance.

Do not operate your wheelchair on the Rampvan® ramp without assistance if you are unable to maintain stability and balance. Counterbalance devices (anti-tippers) may be available from your wheelchair representative to enhance stability and balance.

Do not tilt your wheelchair without assistance. Operate the wheelchair at a slow and constant speed when on the ramp. Do not accelerate suddenly when on the ramp. Do not raise the front wheelchair wheels (pull wheelie) when on the Rampvan® ramp.

The aid of an attendant stabilizing the wheelchair is recommended for **optimum safety**. Wheelchair passengers who intend to enter and exit their Rampvan® without the assistance of an attendant must determine the safest and most practical method and orientation of entering and exiting the Rampvan® based on the physical characteristics of their personal wheelchair and his or her physical capabilities to maintain stability while the wheelchair is in motion on the Rampvan® ramp.

Wheelchair Attendants: When assisting a wheelchair occupant, remember to use good body mechanics. When the wheelchair is on the ramp, the attendant must grasp the push handles (or other) securely. Detachable wheelchair parts such as arms or leg rests must never be used for hand holds or lifting supports. Doing so could result in the detachable parts being inadvertently detached from the wheelchair **resulting in possible injury to the wheelchair occupant and/or the attendant.**

Wheelchair Orientation and Securement During Transport: The wheelchair and occupant **must** face the front of the vehicle and **must** be secured using the Forward-Facing Wheelchair and Occupant Belt and Track System when riding in the Rampvan®. See pages 25-34 for details.

WHEELCHAIR AND OCCUPANT RESTRAINT

One Forward-Facing Wheelchair and Occupant Belt Kit is supplied for the restraint of one wheelchair and occupant (details follow). “L” track is mounted in four locations in the vehicle for belt securement (shown in Figure 1).

Note: Wheelchair passengers shown in Figure 1 depict the available seating positions. Wheelchair capacity at Midpoint (Position C) may have limitations based on the physical dimensions of specific wheelchairs. Additional Forward-Facing Wheelchair and Occupant Belt Kits must be purchased for the restraint of each additional wheelchair passenger.

The Rampvan® offers the following options for placement and securement of wheelchair passengers.

Driver Seat: This seat (Position A) can be removed and adaptive driving systems custom tailored for the driving wheelchair occupant can be purchased from and installed by your local sales representative.

Front Passenger Seat with Floor Track: The passenger seat (Position B) can be removed and the seat location can be utilized by a wheelchair occupant.

Midpoint Lowered Floor Area with Floor Track: The Midpoint lowered floor area (Position C) can be utilized by wheelchair occupants (capacity limitations apply).

Refer to the following guidelines, illustrations, photos and instructions for proper use of the belt and track restraint system.

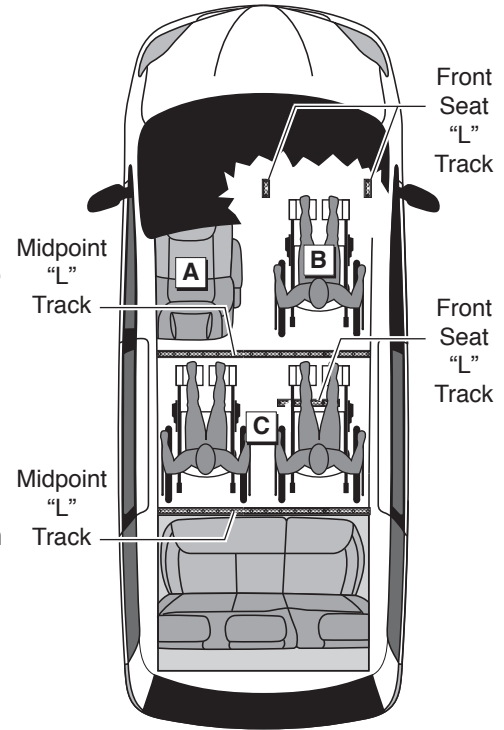

Figure 1

WHEELCHAIR AND OCCUPANT RESTRAINT

⚠️ WARNING

No product developed to date can guarantee successful securement of the wheelchair, even at low speeds, in the event of an accident. The Braun Wheelchair and Occupant Belt/Track System does meet the most widely referenced Federal Motor Vehicle Safety Standards used for contemporary restraint equipment. However, this equipment does not ensure stability of the wheelchair in the event of an accident at any speed.

Wheelchair Securement: Two adjustable over-center buckle belts are provided for securement of the rear of the wheelchair. Two adjustable cam buckle belts are provided for securement of the front of the wheelchair.

The belts are equipped with one keeper fitting (attachment) which installs in the vehicle-mounted “L” track (details on page 29). A hook or a lobster claw-style hook (varies with belt system) is positioned on the opposite end of the belts for attachment to the wheelchair. The hook style belt is shown here. Do not attach belts to detachable wheelchair components such as armrests or leg rests. Front and rear belt tension is required.

Refer to the illustrations, photos and instructions on pages 28-34 for belt operation procedures.



Wheelchair Passenger Securement: One adjustable lap belt extension is supplied for securement of the wheelchair occupant. The extension belt is equipped with one keeper fitting (attachment) which installs in the vehicle-mounted “L” track. A female receptacle is positioned on the opposite end of the extension belt for attachment to a Toyota factory-installed upper torso lap and shoulder belt. See the illustrations on pages 30 and 31 and photos on page 34.

Operate the Toyota lap and shoulder belt as instructed in your Toyota owner’s manual. Follow all safety precautions. Connect the Toyota lap and shoulder belt to the lap belt extension. Position the upper torso (shoulder) belt across the center of the shoulder. Position the lap belt low across the front of the pelvis (near hip). See the illustrations on pages 30 and 31 and photos on page 34.

Position of the lap belt buckle, after adjustment, is to be located near hip position. The belt is to be worn low and snugly. Adjustment of the lap belt extension is to be made at adjuster buckle. Wheelchair occupant

restraints should not be held away from the body by wheelchair components such as armrests or wheels.

Keep belts clear of sharp objects. Do not alter belts. Do not interchange belts from one position to another. Keep the supplied belts together as a complete set.

Belt and Track Maintenance: Inspect belt assemblies frequently. Any defects such as belt cuts, fraying or malfunctioning call for replacement of the entire belt assembly. “L” track must be clean and not worn, bent or otherwise damaged (prohibiting proper belt attachment). If there is any sign of damage, wear, abnormal condition or improper operation of belts, belt hardware (hooks, keepers, latch plate, receptacle), or track, discontinue use and replace components immediately.

Severe conditions (weather, environment, heavy usage, etc.) may require more frequent inspections. Exposure to severe conditions will dramatically reduce the life of the system.

WHEELCHAIR AND OCCUPANT RESTRAINT

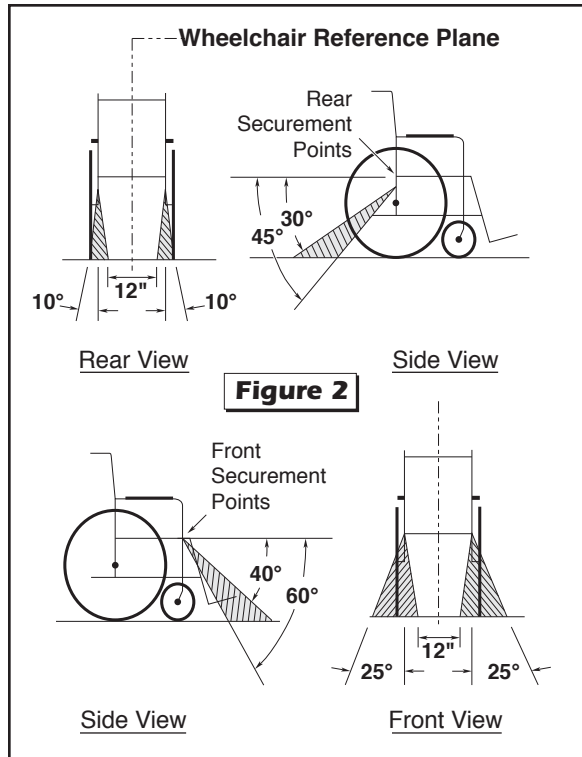

Restraint Belt Angles

Locate wheelchair in forward-facing position centering wheelchair squarely within “L” track. The front and rear belts, when attached, should create angles approximately as shown in Figure 2. Preferred angles and locations of belts from wheelchair securement points to vehicle anchor points are shown. Front tie-downs should be angled out far for lateral stability when possible. **Note:** These are optimum angles and cannot be achieved in some cases.

Keeper Fitting and “L” Track Attachment Instructions

The belts supplied in the Forward-Facing Wheelchair and Occupant Belt/Track System are equipped with keeper fittings (attachments) which engage the “L” track. Engage and release the keeper fittings as detailed and shown on page 29. **Note:** Lift to remove the “L” track plastic covers. Refer to pages 30-34 for belt attachment and release procedures.

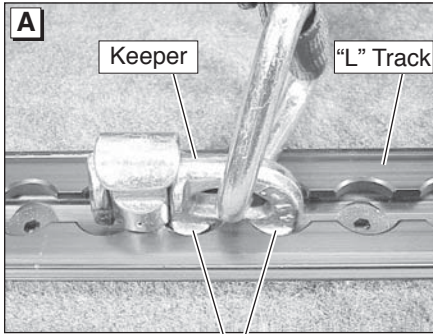

Align engagement feet with holes.

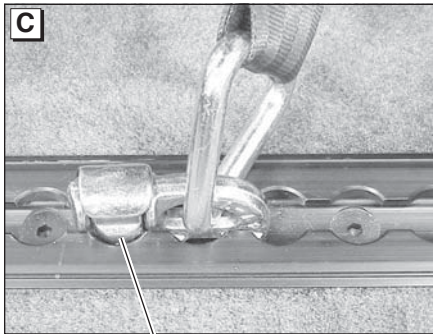

Fully-engaged Keeper

To Engage Keeper Fitting:

1. Insert keeper fitting into track (align two engagement feet with holes in track). See Photo A.
2. Push down on fitting and slide fitting 1/2 slot in either direction until it clicks and locks in position (see Photos B and C). Pull firmly on belt to ensure fitting is locked in track.

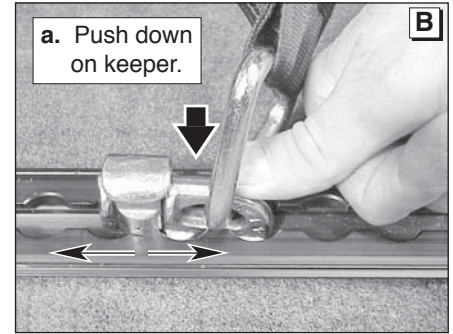

b. Slide keeper 1/2 slot in either direction.

To Release Keeper Fitting:

- Lift plunger and slide fitting 1/2 slot in either direction and lift fitting out of track.

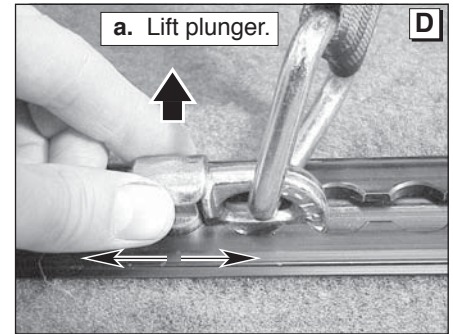

b. Slide keeper and lift.

WHEELCHAIR AND OCCUPANT RESTRAINT

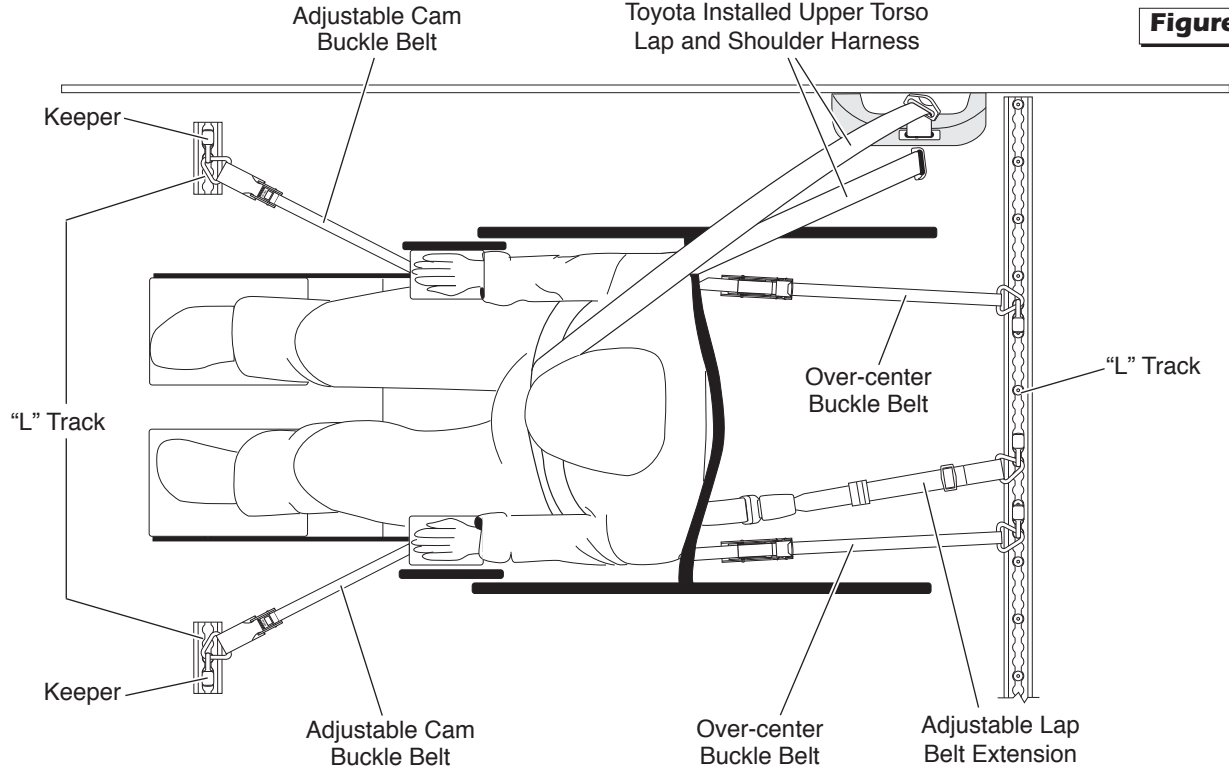

Figure 3

WHEELCHAIR AND OCCUPANT RESTRAINT

Note: Generic seat position shown. Attachment procedures are identical for all positions. Photos on pages 32-34 depict securement of wheelchair in midpoint position.

Keeper attachment details are provided on page 29.

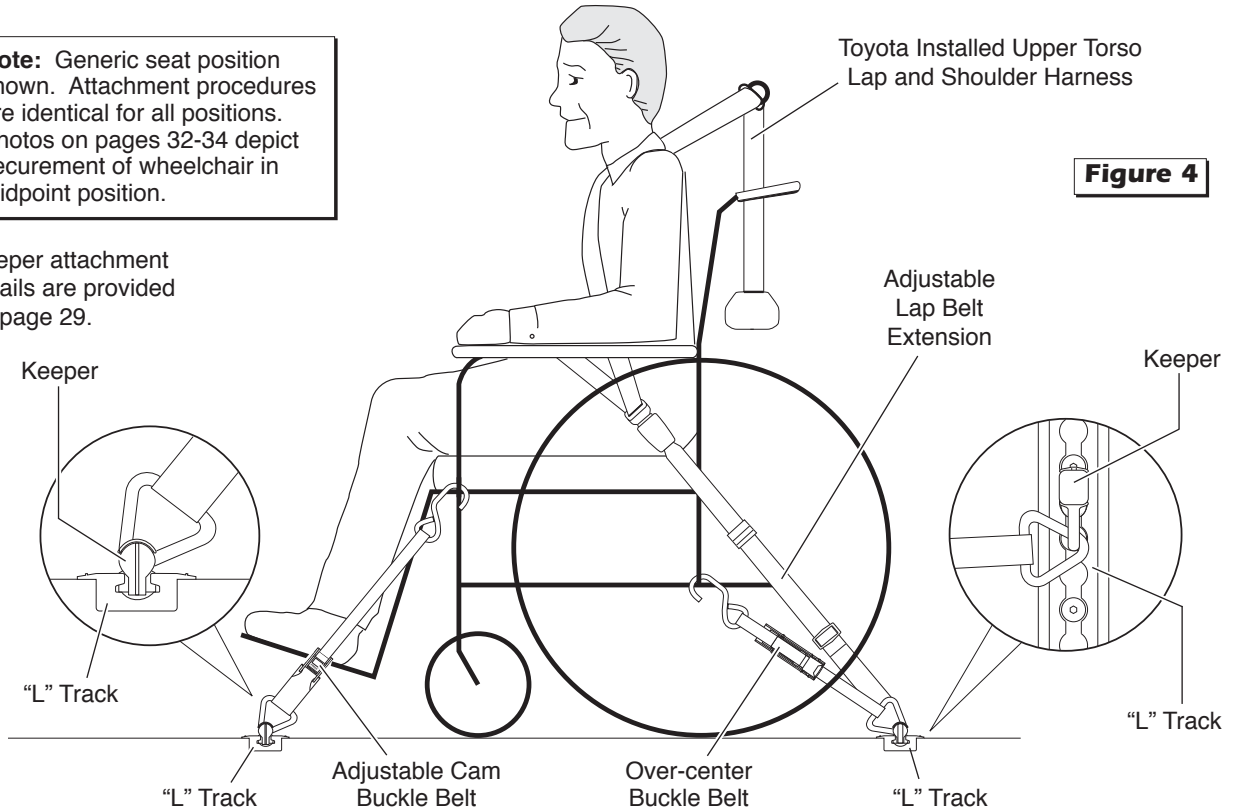

Figure 4

WHEELCHAIR AND OCCUPANT RESTRAINT



Hook

Front Cam Buckle Belt Attachments

1. Connect chair hook to a solid frame member of the chair as shown in Photo E.
2. Position and connect belt keeper fitting (attachment) to appropriate track anchorage point (slots). Attach keeper as detailed on page 29. Pull firmly on belt to ensure fitting is locked in track. **Note:** Belt angles should be as shown in Figure 2 on page 28.
3. Pull loose end of belt until tight (see Photo G).
4. Connect Velcro™ tabs to keep excess belt off floor. See Photo H.

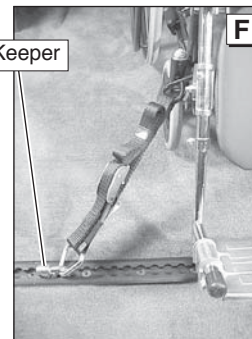

Keeper

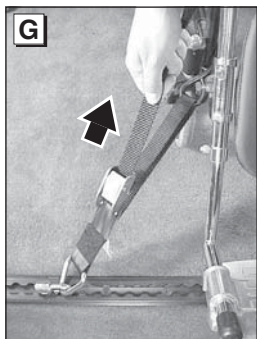

Repeat procedures for opposite side belt.

Belt Release: To release tension on belt, press the buckle cam as shown in Photo I.

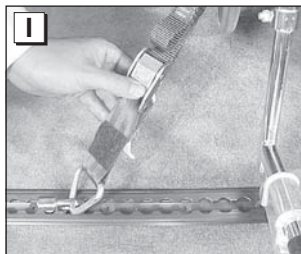

Note: Midpoint seat position shown. Attachment procedures are identical for all positions.

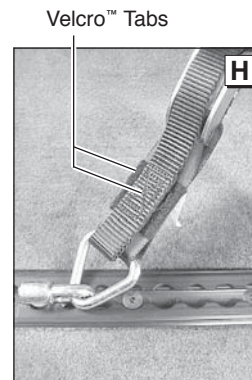

Velcro™ Tabs



Rear Over-Center Belt Attachments

◀ 1. Connect chair hook to a solid frame member of the chair close to the point where the chair back and cushion meet (as shown in Photo J).

Hook
Keeper

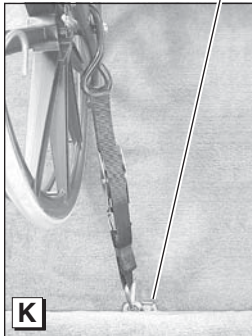

◀ 2. Position and connect belt keeper fitting (attachment) to appropriate track anchorage point (slots). Attach keeper as detailed on page 29. Pull firmly on belt to ensure fitting is locked in track. **Note:** Belt angles should be as shown in Figure 2.

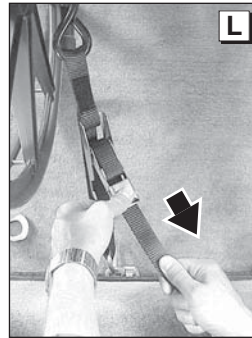

3. With buckle open, pull loose end of belt until tight (see Photo L). While holding the loose end with one hand, close the lever of the clamp (buckle) down until it locks. See Photo M.

▶ 4. Connect Velcro™ tabs to keep excess belt off floor. See Photo N.

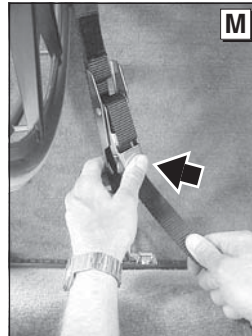

Repeat procedures for opposite side belt.

Note: Check to see that front and rear belts are tight and the chair is secure enough that it does not have any movement. Lock wheelchair brakes.

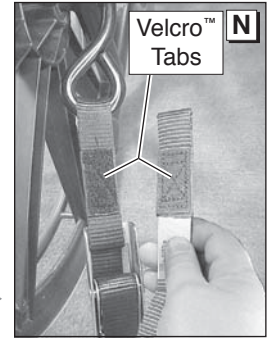

Belt Release: Press lever clamp (lock) to release tension on belt.

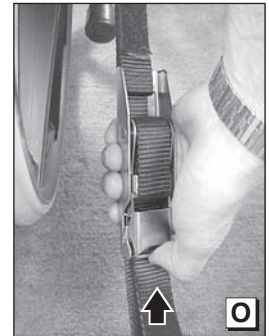

WHEELCHAIR AND OCCUPANT RESTRAINT



Extension Belt

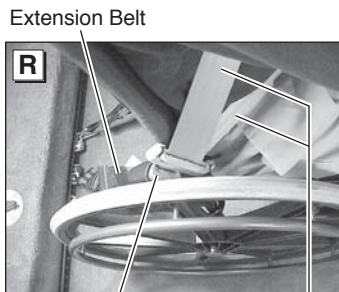

Extension Belt

Receptacle

Toyota Lap and Shoulder Belt

Lap and Shoulder Belt Attachments

Refer to Photos P-S.

1. Position and connect the adjustable lap belt extension keeper fitting (attachment) to appropriate track anchorage point (slots). Attach keeper as detailed on page 29. Pull firmly on belt to ensure fitting is locked in track.
2. Connect the lap and shoulder belt to the lap belt extension (insert latch plate in female receptacle). Position the upper torso (shoulder) belt across the center of the shoulder. Position the lap belt low across the front of the pelvis (near hip). See Photos P-S.

Wheelchair occupant restraints should not be held away from the body by wheelchair components such as wheelchair armrests or wheels.

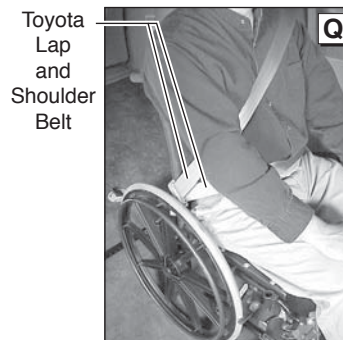

Toyota Lap and Shoulder Belt

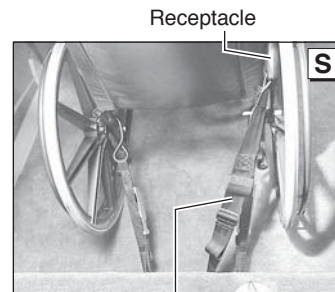

Receptacle

Extension Belt

Front Seats: In an effort to produce vehicles that can be configured to meet a variety of customer needs, the driver and passenger seat bases have been designed so they may be removed. This feature allows the owner and sales representative to determine the appropriate seating arrangement to accommodate owner needs.

WARNING

Park vehicle and turn engine off before removing or installing seats. Failure to do so may result in serious bodily injury and/or property damage.

Once the desired seat arrangement is determined, all power seat electrical harnesses must be re-connected to the appropriate fixed seat positions.

Rampvan® front seats are equipped with quick-release seat attachments (making seat removal and installation procedures simple). The quick-release front seats are installed and removed as detailed on pages 38 and 39 of this manual.

Power Seats: Rampvan® front seats are equipped with electrical wiring harnesses to accommodate optional equipment such as heated seats, air bags, etc. **Before removing seats, be certain all seat electrical harnesses are disconnected.**

When seats are removed, **connect the seat electrical harness plug to the storage receptacle to avoid damaging the harness or plug.**

Note: The storage receptacle is located at the top of the seat base, (see photo on next page).

When positioning seats, it is **your responsibility** to reconnect all seat electrical harnesses. Failure to properly connect power seat electrical harnesses may result in power seat functions being disabled and/or the air bag light illuminating.

Contact your sales representative or call The Braun Corporation at 1-800-THE LIFT® if any of this information is not understood.

SEAT REMOVAL AND INSTALLATION

Front Seat Wiring Harnesses:

Rampvan® front seats are equipped with electrical wiring harnesses.

A vehicle electrical harness receptacle is located to the rear of each seat base in the wall (at “B” pillar). The seat wiring harness plug connects to the receptacle. **Before removing seats, be certain seat wiring harnesses are disconnected.**

⚠ CAUTION

Disconnect seat wiring harness before removing seat. Failure to do so may result in property damage.

When removing seats, the **seat electrical harness plug must be connected to the storage receptacle** provided at the top of the seat base. When installing seats, **be certain seat wiring harnesses are reconnected.** Failure to do so may result in power seat functions being disabled and/or the air bag light illuminating.

Screw-on Connectors: Front seat wiring harnesses are equipped with a screw-on connector (plug). Operate connectors as detailed on page 37. Alignment grooves (slots) are provided in receptacle sockets. Receptacle sockets have a single wider alignment groove that is positioned at 12 o'clock. Seat wiring harness plugs are equipped with mating alignment guides (ears).



Storage Receptacle



Seat Wiring Harness

Vehicle Receptacle

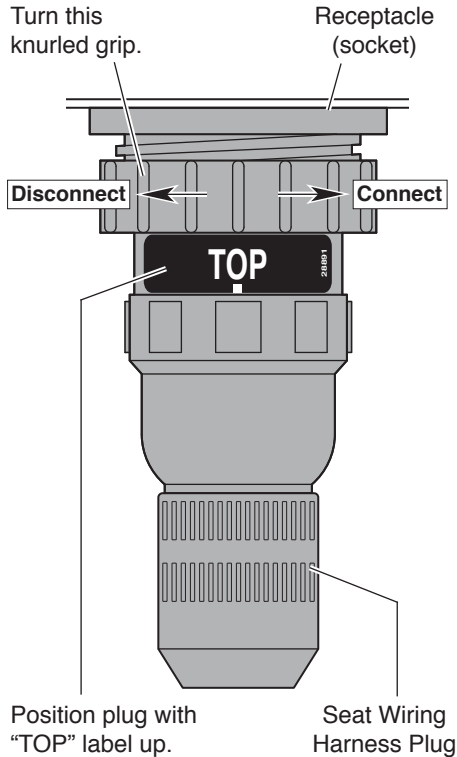

Screw-on Connectors:

To Connect: Align the seat harness connector by positioning the plug with the "TOP" label facing up. Align the seat harness connector alignment guides with the receptacle socket alignment grooves (will only connect one way).

Carefully insert the seat harness plug in the receptacle socket. Turn seat harness connector large diameter knurled grip clockwise fully (turn gripper nearest to socket).

To Disconnect: Turn seat harness connector large diameter knurled grip counterclockwise and disengage connectors.

Alignment Groove
(at 12 o'clock)

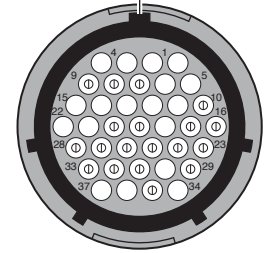

Receptacle Socket

Alignment Guide

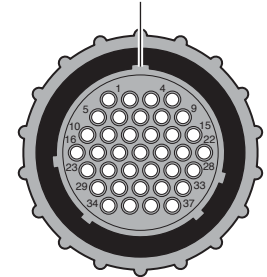

Seat Harness Plug

SEAT REMOVAL AND INSTALLATION

Front Seat Bases:

Quick-release seat base attachments engage recessed floor strikers (supports). A release handle is located at the rear of the seat base. Pulling the release handle disengages the attachments and allows easy removal of the seat.

Illustrations depict seat base only.

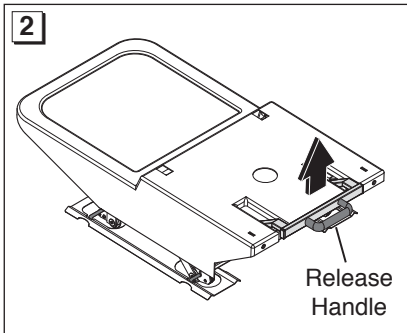

Pull release handle up.

Front Seat Removal Instructions

1. **Caution! Disconnect seat wiring harness before removing a front seat base.** See pages 36 and 37 for wiring harness details.
2. Connect harness to seat base storage receptacle. See page 36 for details.
3. Grasp and pull handle up.
4. Pull up (a) and back (b) on the rear of seat. **Note:** Push top of seat forward while pulling handle for easier disengagement.
5. Roll seat base out of vehicle as shown.

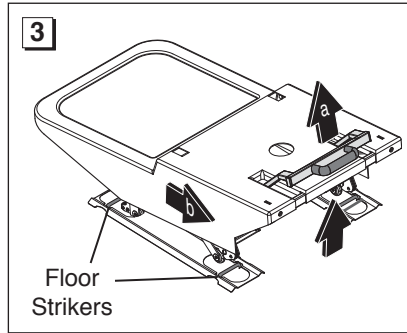

Pull seat up (a) and back (b).

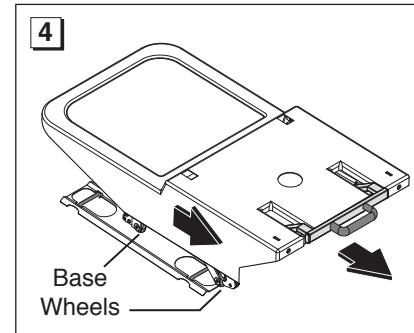

Roll seat out of Vehicle

Front Seat Installation Instructions

1. Roll seat base into position, just behind the floor mounted strikers. Pull up the release handle.
2. Lift the rear of the seat base up (a) and slide it forward (b) to engage the front strikers.
3. Push down on rear of seat to engage rear strikers. Push down the release handle to lock the seat base into place.
4. Connect (plug) seat electrical harness to B-pillar receptacles. See pages 36 and 37 for details.

⚠ WARNING

Seat attachments must be fully latched in floor supports before occupying seats or operating vehicle. Failure to do so will result in serious bodily injury.

Illustrations depict seat base only.

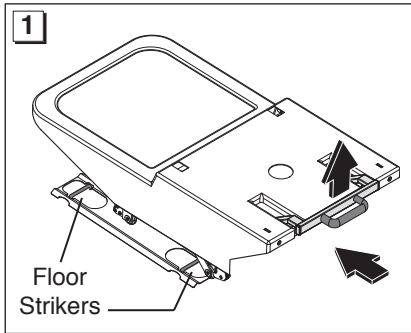

Position seat and pull release handle up.

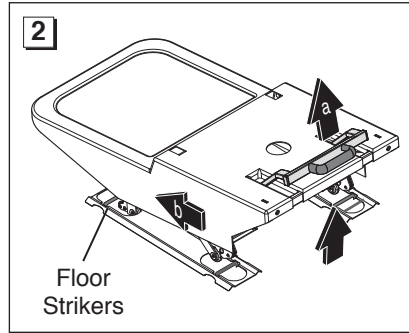

Lift up (a) and slide forward (b) to engage front strikers.

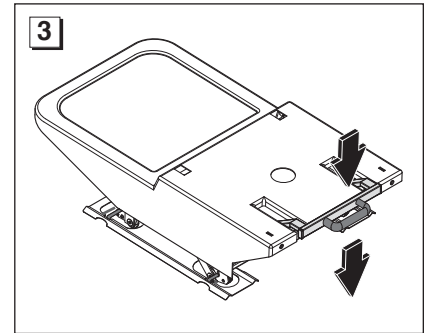

Push down to engage rear strikers. Push down handle to lock into place.

SEAT REMOVAL AND INSTALLATION

Third Row Power Seat Operation

Third row folding power seats have been modified during Rampvan® conversion procedures. The seat back automatic fold/return feature has not been affected by the modifications. Fold and return the seat back as outlined below and detailed in the Toyota OEM owner's manual. The seat stow feature has been **disabled**. The rear seat must be removed to utilize the full rear cargo area. Remove and install the seat as detailed.

Folding and Returning Third Row Power Seat

The seat FOLDING/RETURNING switches are located in the upper hatch opening (header interior panel). Use this switch to automatically fold and return the seat back.

To Fold Seat Back: Push the overhead FOLDING/RETURNING switch to fold the seat down.

To Return Seat Back: Push the overhead FOLDING/RETURNING switch to return the seat to the original position (vertical).

Seat Back Angle: Use the control switch located at the front outboard corner of the seat base to adjust the seat back angle.

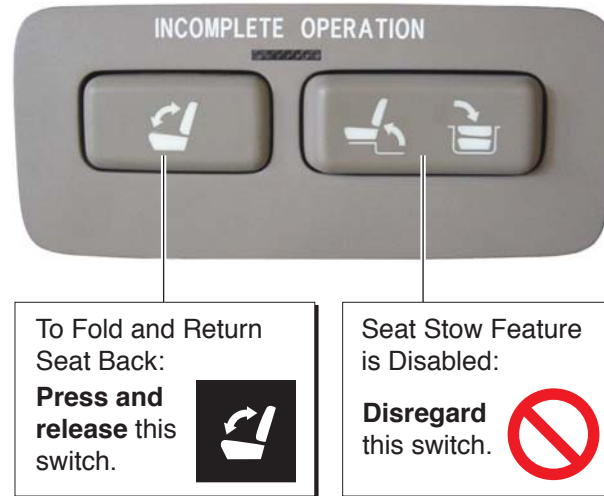

Third Row Power Seat Removal and Installation

The modified seat bases are equipped with “easy-out” type attachments. The attachments engage recessed floor strikers. The two rear locking attachments are released and latched using the latch handle. Once the rear attachments have engaged the strikers, push the latch handle down to lock the seat in position. Lift the handle to release the rear attachments. Remove and install the seats as detailed on pages 42 and 43.

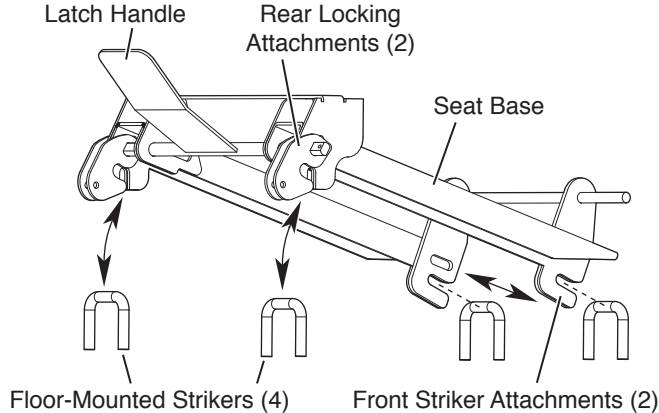

Third Row Power Seat Wiring Harnesses

Third row power seats are equipped with electrical wiring harnesses. **Seat wiring harnesses must be disconnected** during seat removal procedures. When removing seats, the **seat electrical harness and plug must be secured to avoid damage**. When installing rear power seats, **be certain seat wiring harnesses are reconnected**. Failure to do so may result in power seat functions being disabled.

CAUTION

Disconnect seat wiring harness before removing seat. Failure to do so may result in property damage.

SEAT REMOVAL AND INSTALLATION

Third Row Power Seat Removal

1. Fold the seat back down (push FOLDING/RETURNING switch).
2. Lift latch handle at rear of seat base to disengage rear seat attachments from floor strikers. See Figures A and B.
3. Lift rear of seat. See Figure B.
4. **Caution: Carefully disconnect seat wiring harness from floor harness** (located under seat).
5. Pull seat base back to disengage front seat attachments from floor strikers. Remove seat. See Figure C

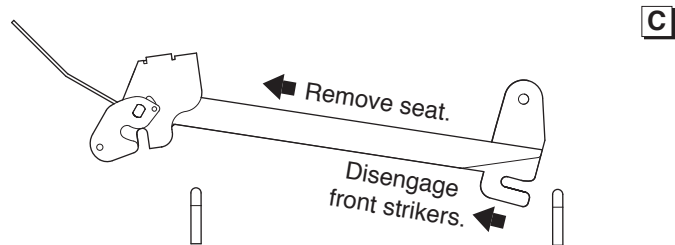
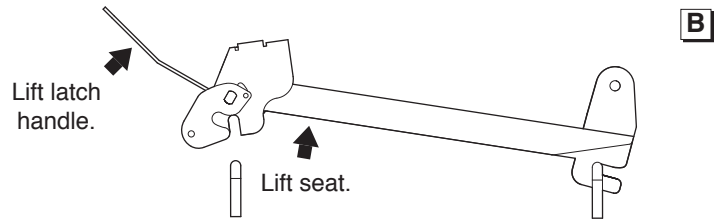
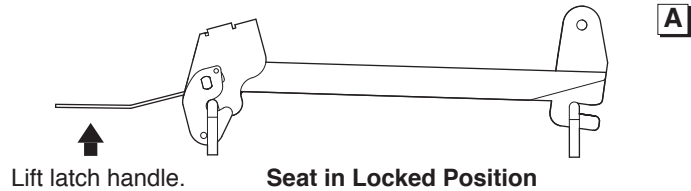

Third Row Power Seat Installation

1. Position seat (engage front seat attachments with floor strikers). See Figure D. **Caution: Do not damage seat or floor wiring harnesses** (located under seat).
2. Lift rear of seat and **connect seat wiring harness to floor harness**. Position harnesses clear of seat attachments.
3. Align rear seat attachments with floor strikers. Lift latch handle at rear of seat base to open the rear locking attachments. Lower rear of seat to engage rear seat attachments with strikers. See Figure E.
4. Push latch handle down fully to lock rear attachments. See Figure F.

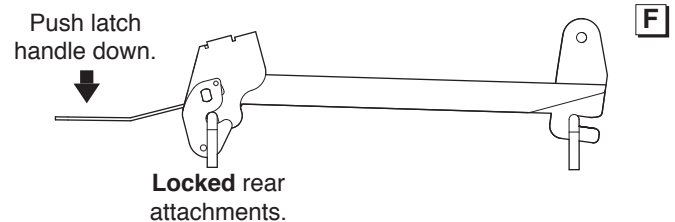
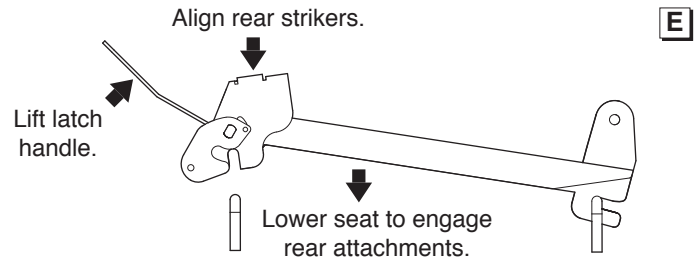
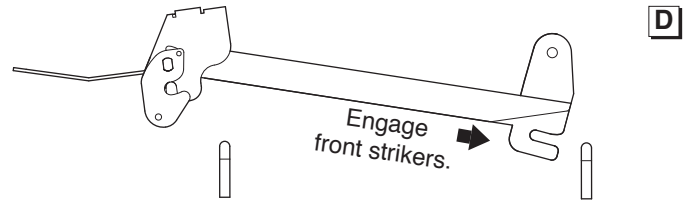

SEAT REMOVAL AND INSTALLATION

Third Row Non-Power Seat Removal:

1. Fold down the back of the seat using the TO FOLD/LIFT SEATBACK strap (straps available front and rear of seat back). **Note:** The front strap is not labeled (see Photo A). The strap at the back of the seat is labeled (see Photo B).
2. Pull the TO STOW/USE strap at the back of the seat (see Photo B) and lift the rear of the seat assembly up. The seat will flip up as shown in Photo C.
3. Remove hairpin cotter from the floor mounted stud securing the seat assembly gas spring to the vehicle floor. Remove the gas spring from the stud (see Photos C and D).
4. Pull strap at the bottom of the seat to release the front latches (see Photo E).
5. **Carefully** remove seat.

TO FOLD/LIFT SEATBACK Strap

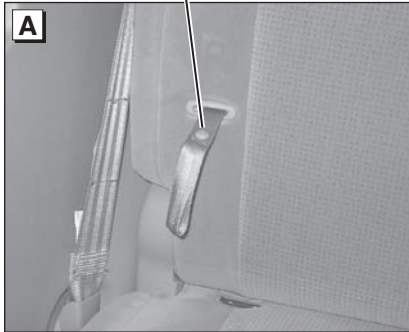

TO FOLD/LIFT SEATBACK Strap

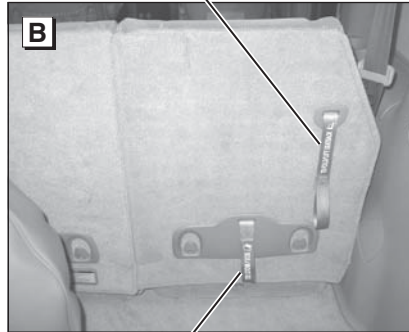

TO STOW/USE Strap

Gas Spring

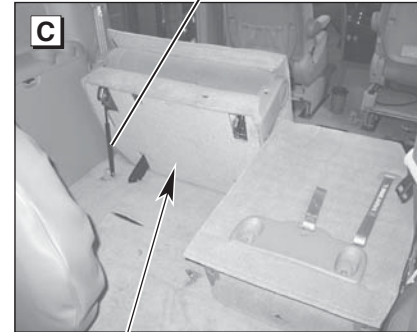

Rear seat in the "Flipped up" position.

Third Row Non-Power Seat Installation:

1. Fold down the seat back **before** moving the seat into the vehicle.
2. **Carefully** move the seat into position, but don't engage the front latches at this point.
3. Reconnect the seat assembly gas spring to the floor mounted

stud with the hairpin cotter (see Photos C and D).

4. Pull the front latch release strap located under the seat and push the front seat latches into the floor mounted strikers. Ensure the latches are engaged with the strikers (flip

down the seat, raise the seat back and attempt to move seat back and forth).

Note: Rear bench seat removal and installation procedures typical for both sections of third row 60/40 split seats

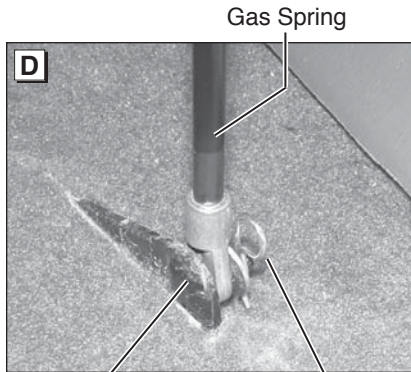

Mounting Pin

Hairpin Cotter

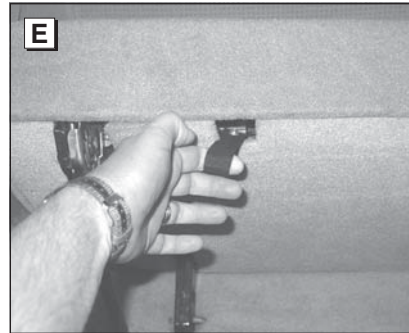

Front Latch Release Strap (under seat)

⚠️ WARNING

Install seats as specified before occupying seats or operating vehicle. Failure to do so may result in serious bodily injury and/or property damage.

PREVENTIVE MAINTENANCE

Maintenance is necessary to ensure safe and trouble-free Rampvan® operation. General preventive maintenance consisting of inspections of your Rampvan® systems along with cleaning and lubricating procedures should be a part of your routine (lubrication requirements are minimal). Keeping the passenger side slide door lower track pan free of debris, ice and snow is one of the most effective preventive maintenance practices to exercise. Regular preventive maintenance procedures will increase the service life of the Rampvan®, as well as enhance safety.

During routine inspections, operate all Rampvan® systems and note the following (as equipped):

- Is the power source adequate or weak?

- Does the electronic control system function properly?
- Do the control switches function properly?
- Does the kneel system function properly?
- Does the power slide door function properly?
- Does the ramp deploy and stow properly?
- Inspect wheelchair and occupant restraint belts, buckles and hardware for damage, wear, abnormal condition or improper operation.

Rampvan® ramps are equipped with sealed bearings and Teflon™ bushings to decrease wear, provide smooth operation and extend the service life of the ramp. A “dri-film” style of light oil should be applied to the ramp inboard pivot points and the outboard ramp extension hinge (goes on wet then dries).

Lubricants of this type are available that do not attract dust or debris. Clean the components and the surrounding area before applying lubricants. Use of improper lubricants can attract dirt or other contaminants which could result in wear or damage to components.

Inspect and clean as detailed frequently and routinely (minimum four weeks or 100 cycle intervals). Lubricate the ramp as specified approximately every three months.

Note: These intervals are a general guideline and will vary according to frequency of use and conditions. Exposure to severe conditions (weather, environment, heavy usage, etc.) may require inspection and maintenance procedures to be performed more often.

Preventive maintenance visual inspections, cleaning and lubrication procedures **do not** take the place of the procedures specified in the Maintenance and Lubrication Schedule provided in the Rampvan® service manual. The procedures outlined in the Maintenance and Lubrication Schedule **must be performed at the recommended scheduled intervals by an authorized Braun Corporation service representative who has attended and been certified by The Braun Corporation Sales and Service School.**

If there is any sign of damage, wear, abnormal condition or improper operation, **discontinue Rampvan® use immediately.** Contact your sales representative or call The Braun Corporation at 1-800-THE LIFT®. One of our Product Support representatives will direct you to an authorized service technician who will inspect your Rampvan®.

⚠ WARNING

Maintenance and lubrication procedures must be performed by authorized service personnel as specified in the applicable Rampvan® service manual. Failure to do so may result in serious bodily injury and/or property damage.

JACKING AND TIRE CHANGING INSTRUCTIONS

Jacking and Tire Changing

Interior Spare Tire Mount: The spare tire is located behind the third row seats. The jack and lug nut wrench are attached to the spare tire mount. The jack crank handle is stored inside the rear passenger side wall compartment (attached to compartment door).

Jack Points: Front and rear wheel jacking points have been repositioned during Rampvan® conversion procedures. See Figure at right. The modified vehicle jack points feature a U-shaped bracket that seats into the jack.

Detailed tire changing instructions are provided in the Toyota-supplied owner's manual.

Run-Flat Tires: Some vehicles are equipped with run-flat (RFT) tires. Spare tires and tire changing tools are not supplied with Rampvans equipped with run-flat tires.

Refer to the Toyota-supplied manual for tire changing instructions and safety precautions, as well as instructions regarding other roadside emergencies.

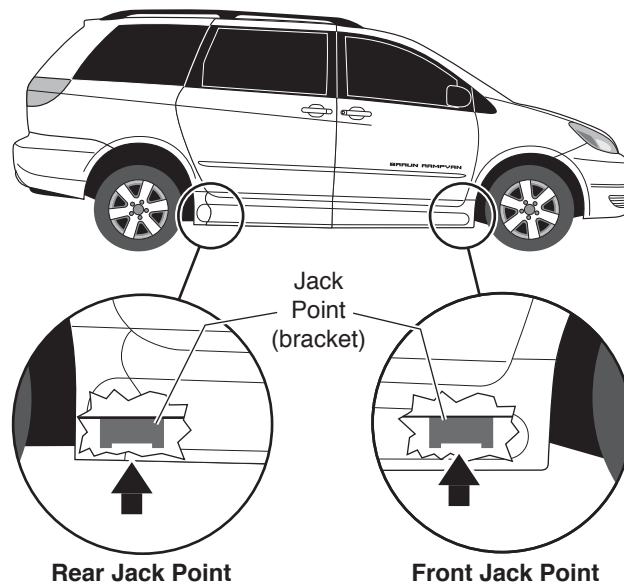

Reporting Safety Defects to the United States Government

If you believe that your vehicle has a defect which could cause a crash or could cause injury or death, you should immediately inform the National Highway Traffic Safety Administration (NHTSA) in addition to notifying the Braun Corporation.

If NHTSA receives similar complaints, it may open an investigation, and if it finds that a safety defect exists in a group of vehicles, it may order a recall and remedy campaign. However, NHTSA cannot become involved in individual problems between you, your dealer or the Braun Corporation.

To contact NHTSA, you may either call the Auto Safety Hotline toll-free at 1-800-424-9393 (or 366-0123 in Washington, D.C. area) or write to:

NHTSA, U.S. Department of Transportation
Washington, D.C. 20590

You can also obtain other information about motor vehicle safety from the Hotline.

Reporting Safety Defects to The Braun Corporation

In addition to notifying NHTSA we certainly hope you will notify us. Please call us at 1-800-THE-LIFT®, or write:

The Braun Corporation
631 West 11th Street
P.O. Box 310
Winamac, IN 46996 USA

BELOW FLOOR OBSTRUCTIONS

Below-Floor Obstructions

When installing an electrical tie-down, power seat or other auxiliary electrical device in an Rampvan®, obstructions below the floor must

be avoided. Obstructions include wiring, fuel system, brake lines, etc. Installers must be aware of these obstructions.

Refer to the illustration on the following page when installing aftermarket equipment to avoid contacting or damaging vital components under the floor. **Drilling or cutting into such obstructions may result in potential hazards as well as property damage.**

Note: Some wiring harnesses shown may not be present. Avoid all harness locations.

WARNING

Check for obstructions such as wires, gas lines, exhaust, etc. before drilling or cutting through floor. Failure to do so may result in serious bodily injury and/or property damage.

WARNING



Risk of electrical fire! Install and electrically terminate auxiliary electrical device as specified by device manufacturer.

BELOW FLOOR OBSTRUCTIONS

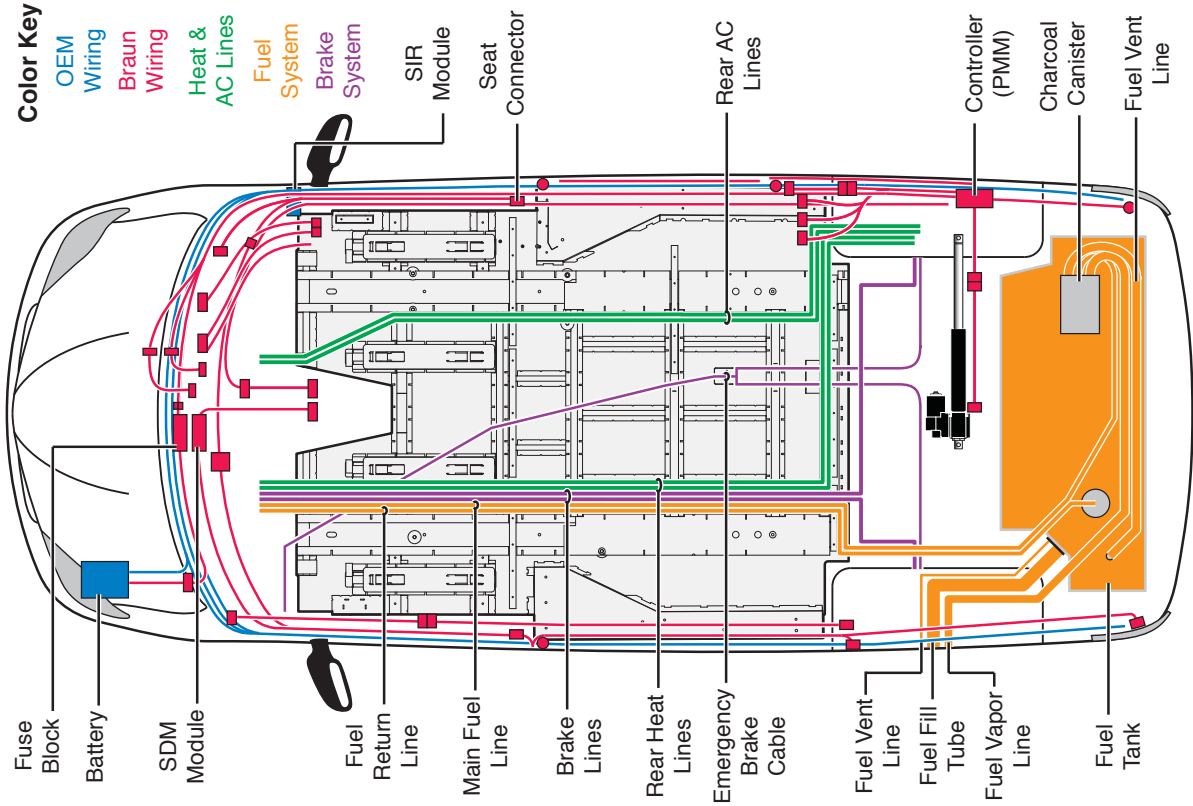

TOWING

Towing with a Rampvan®

Use of this lowered floor conversion vehicle for towing is **prohibited**.

If your Rampvan® Needs Towed

If case of service, The Braun Corporation recommends that this lowered floor conversion vehicle be transported on a trailer rather than towed with one set of wheels suspended and the other set of wheels remaining in road contact.



"Providing Access to the World"®



**Over 300 Braun
Dealers Worldwide**



Life is...
Challenges, and how
you overcome them.
Bob W. Brown

32899 Rev. D

September 2008

Patent Pending

